



US00D442911S

(12) **United States Design Patent** (10) **Patent No.:** **US D442,911 S**  
**Essig et al.** (45) **Date of Patent:** **\*\* May 29, 2001**

(54) **TWO-PIECE HARDTOP FOR A SPORT UTILITY VEHICLE**

**OTHER PUBLICATIONS**

(75) Inventors: **Richard C. Essig**, Berthoud, CO (US);  
**John P. Vanderhoef**, Hyannis, MA (US)

Steel Horse Catalog 1995.

\* cited by examiner

(73) Assignee: **Bestop, Inc.**, Broomfield, CO (US)

*Primary Examiner*—Stacia Cadmus

(74) *Attorney, Agent, or Firm*—W. Scott Carson

(\*\*) Term: **14 Years**

(57) **CLAIM**

(21) Appl. No.: **29/113,192**

The ornamental design for a two-piece hardtop for a sport utility vehicle, as shown and described.

(22) Filed: **Nov. 1, 1999**

**DESCRIPTION**

(51) **LOC (7) Cl.** ..... **12-16**

(52) **U.S. Cl.** ..... **D12/404**

(58) **Field of Search** ..... D12/401, 404,  
D12/403, 90-92, 86; 296/218, 224, 210,  
102, 213, 10, 183-186, 216, 220, 222

FIG. 1 is a side view of a first embodiment of a sport utility vehicle with a two-piece hardtop showing our new design. The vehicle is shown in dotted lines for illustrative purposes only and forms no part of the claimed design.

FIG. 2 is a right side elevational view thereof, the left side elevational view being symmetrical thereto.

FIG. 3 is a bottom plan view thereof.

FIG. 4 is a top plan view thereof.

FIG. 5 is a rear elevational view thereof.

FIG. 6 is front elevational view thereof.

FIG. 7 is a right side elevational view of a second embodiment of a sport utility vehicle with a two-piece hardtop showing our new design. The vehicle is shown in dotted lines for illustrative purposes only and forms no part of the claimed design.

FIG. 8 is a right side elevational view thereof, the left side elevational view being symmetrical thereto.

FIG. 9 is a bottom plan view thereof.

FIG. 10 is a top plan view thereof.

FIG. 11 is a rear elevational view thereof; and,

FIG. 12 is front elevational view thereof.

(56) **References Cited**

**U.S. PATENT DOCUMENTS**

D. 257,531	11/1980	Hickman et al. .	
D. 267,487	1/1983	Ragsdale .	
D. 268,408 *	3/1983	Raggles .....	D12/404
D. 291,676	9/1987	Noble .	
D. 304,436	11/1989	Pike .	
D. 324,196	2/1992	Muth .	
D. 342,470	12/1993	Lomax, Jr. et al. .	
D. 383,710	9/1997	Guichard et al. .	
D. 389,094	1/1998	Stollery .	
D. 391,900	3/1998	Skoog .	
D. 408,781	4/1999	Gordon .	
2,682,427	6/1954	Bright .	
4,930,835	6/1990	Bruce et al. .	
5,314,225	5/1994	Gordon .	
5,725,273	3/1998	Vernon et al. .	
6,003,936	12/1999	Gordon .	

**1 Claim, 6 Drawing Sheets**

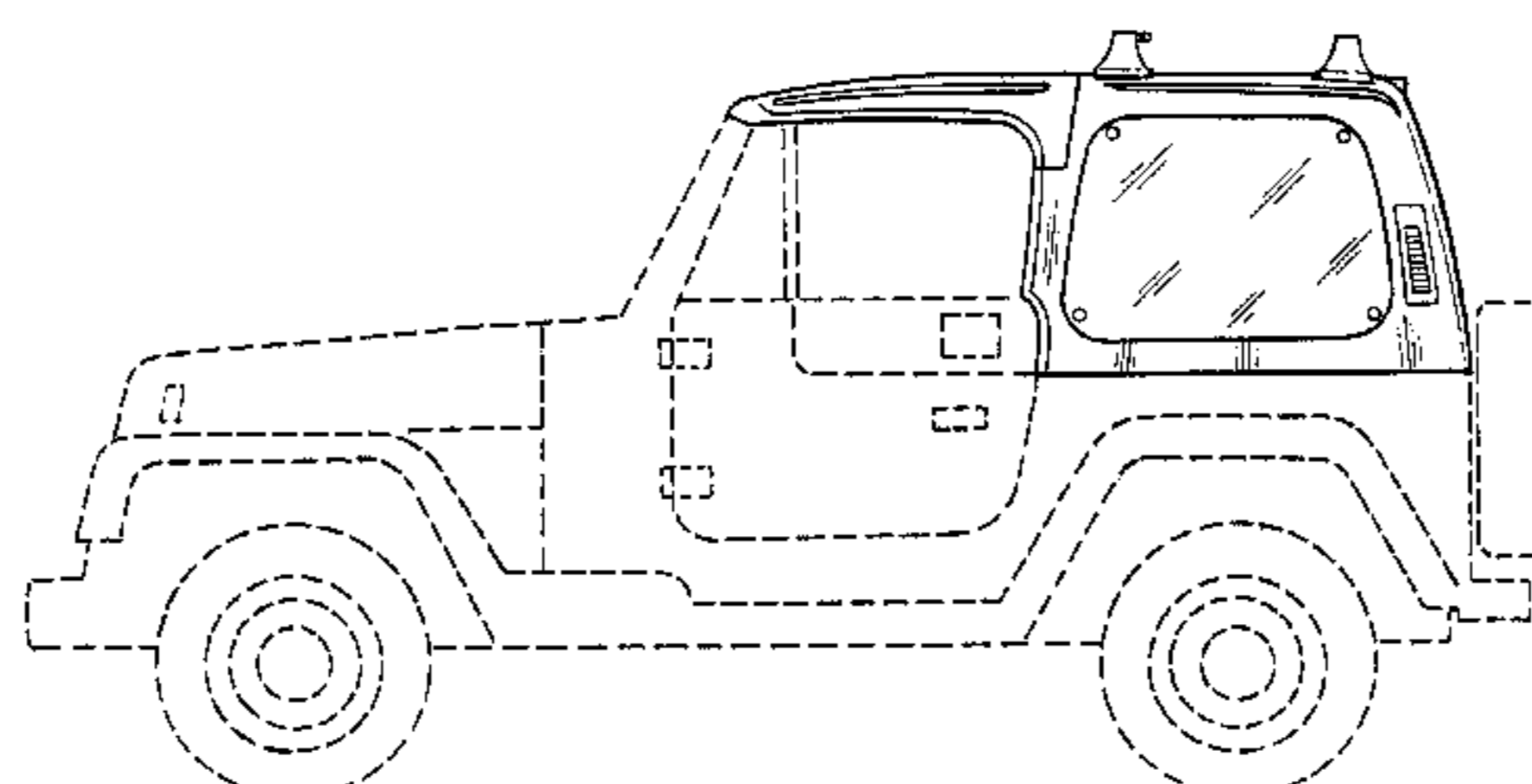
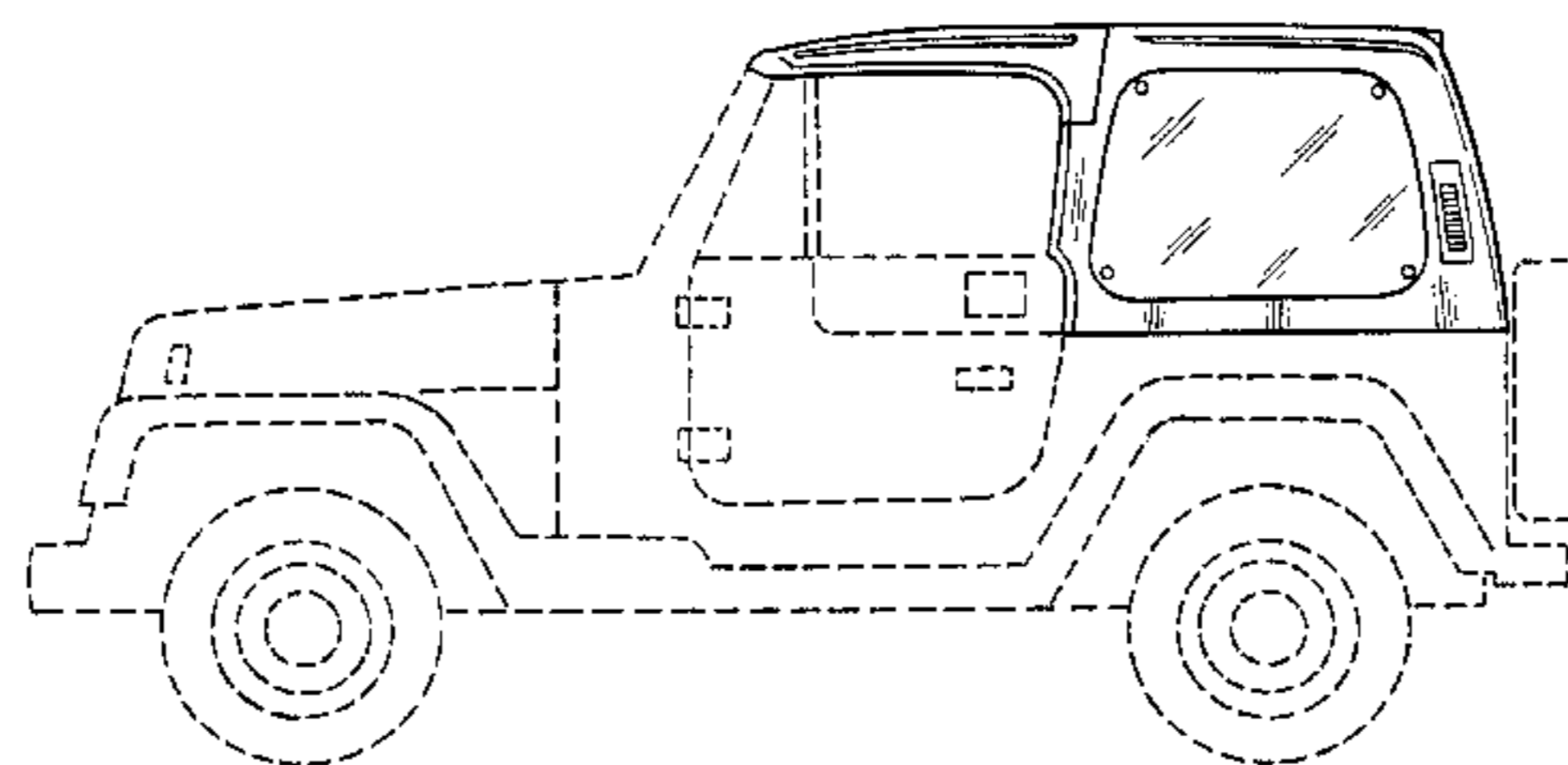

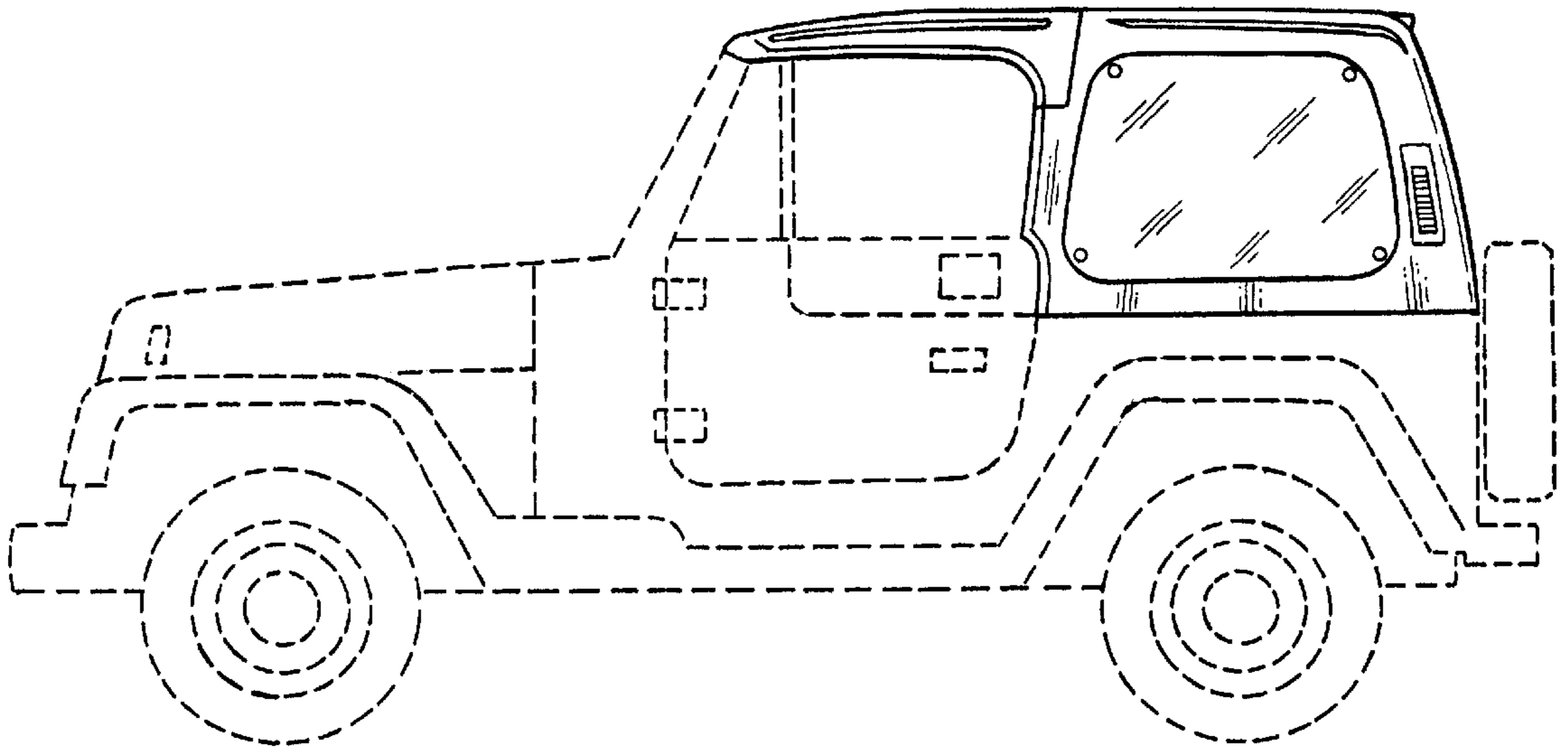

Fig. 1

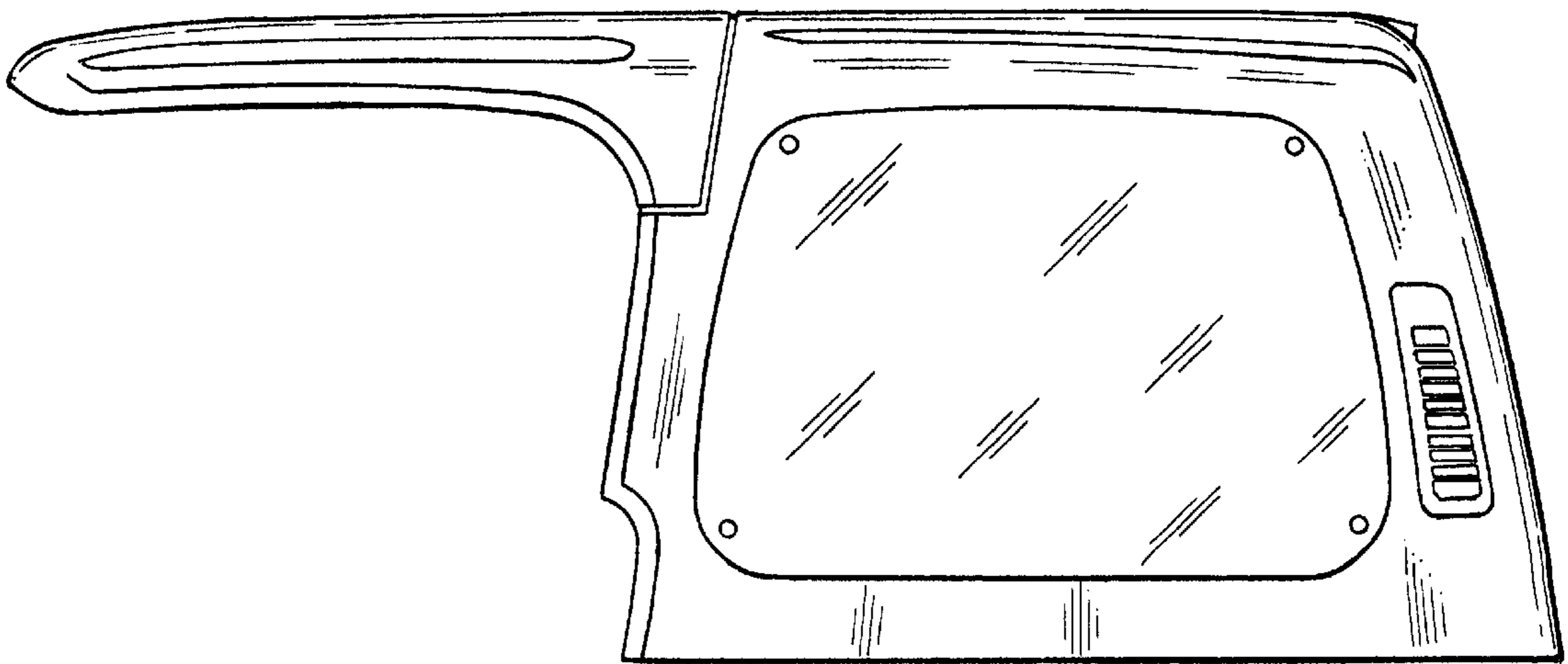

Fig. 2

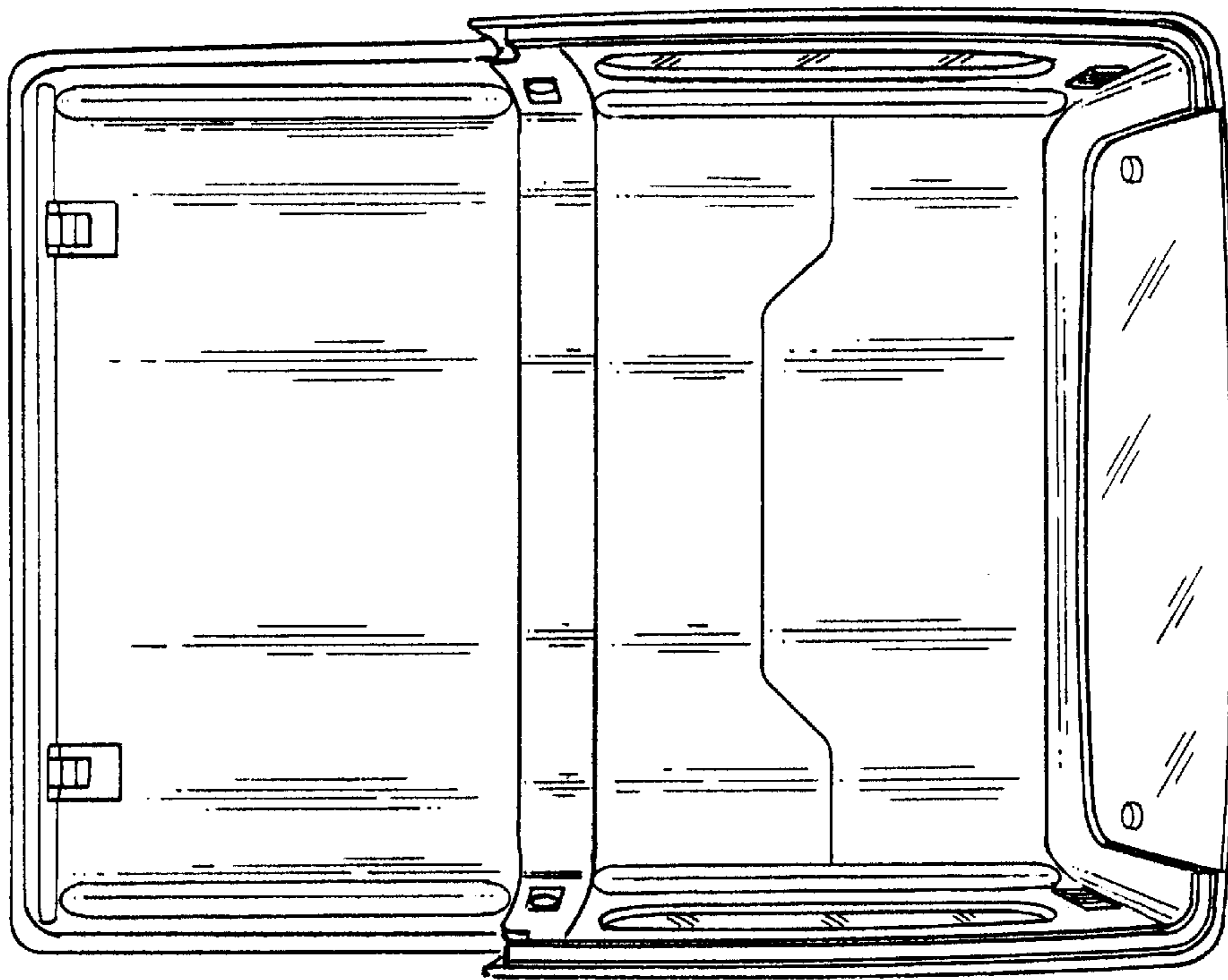

Fig. 3

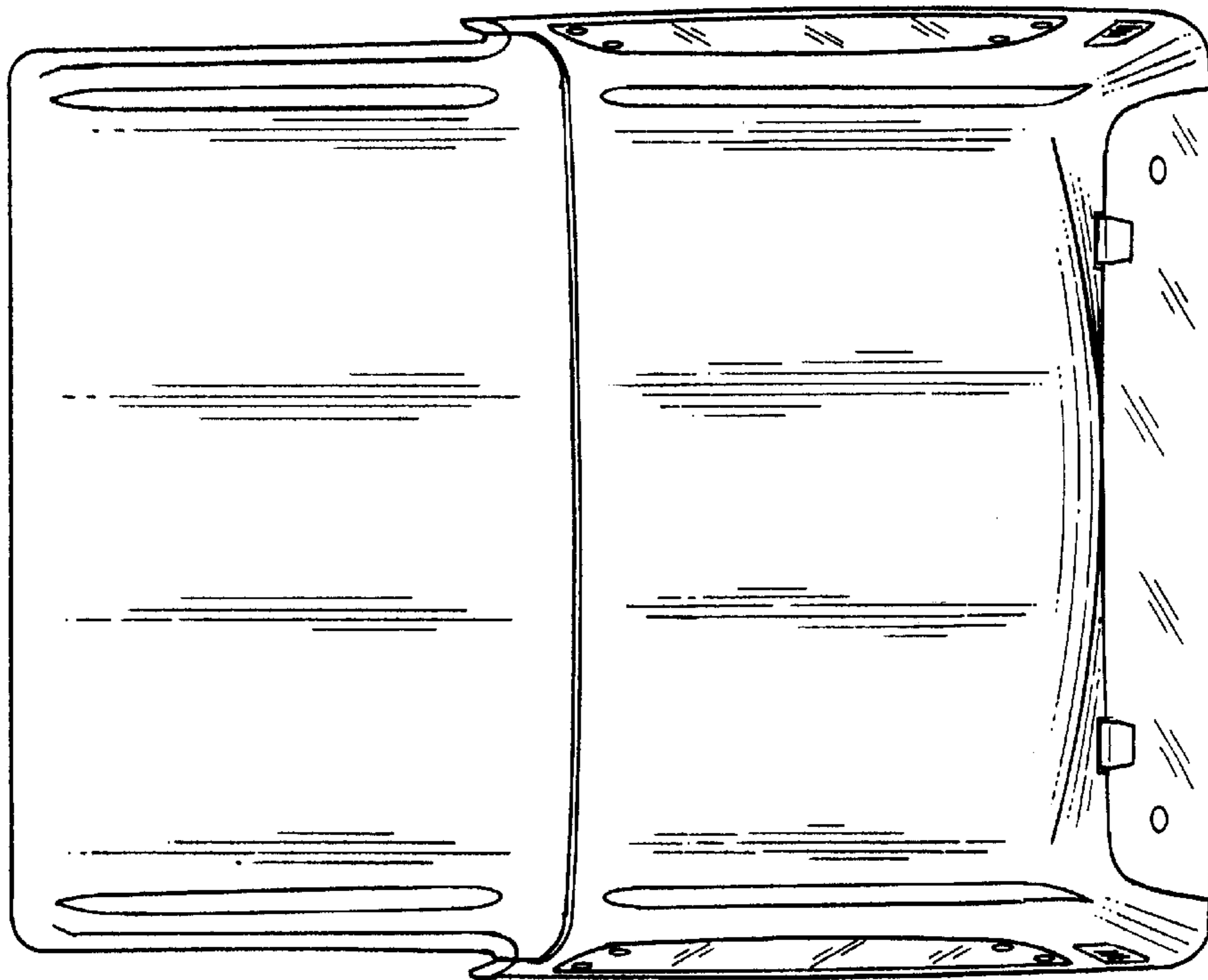

Fig. 4

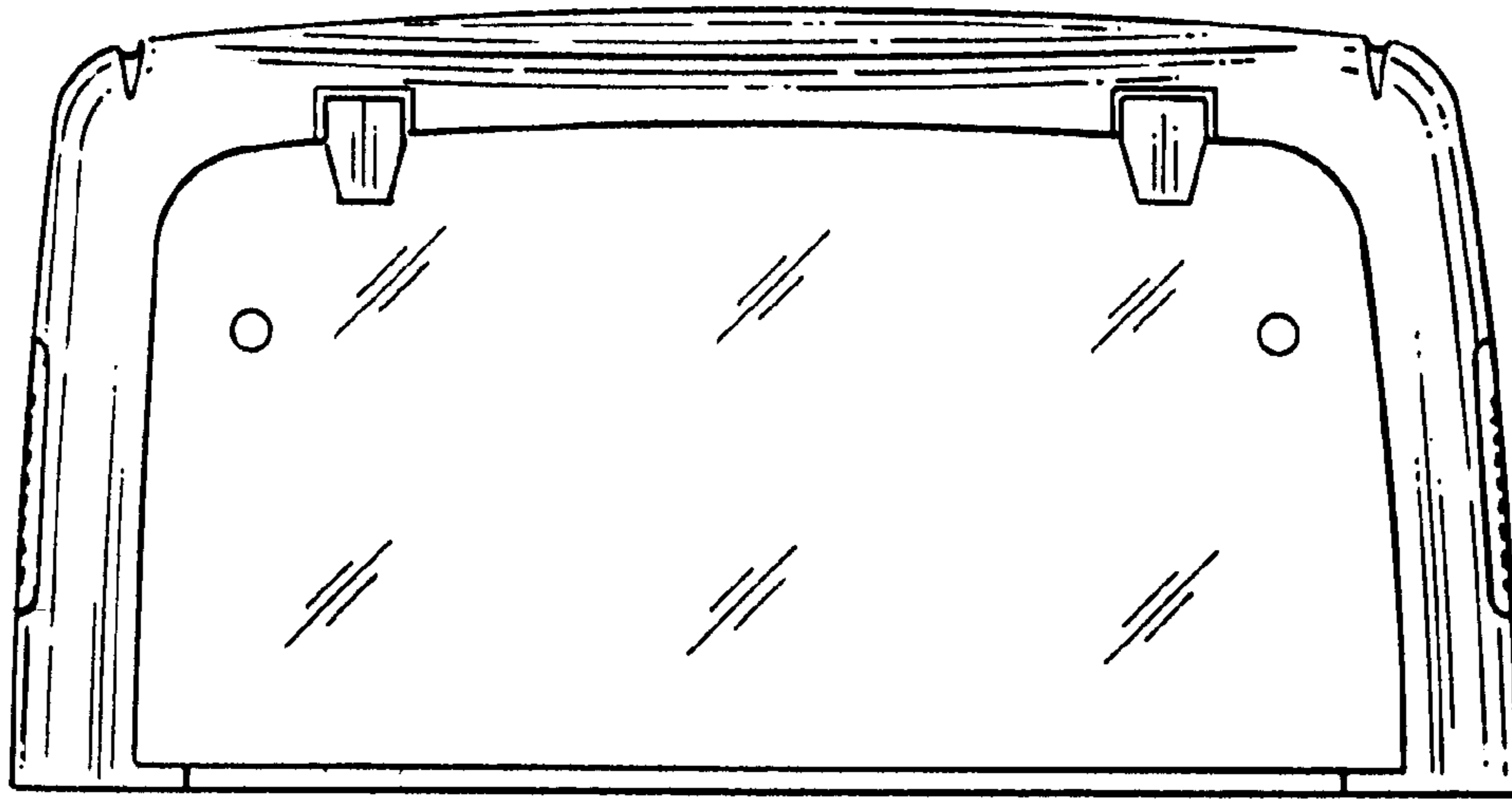

Fig. 5

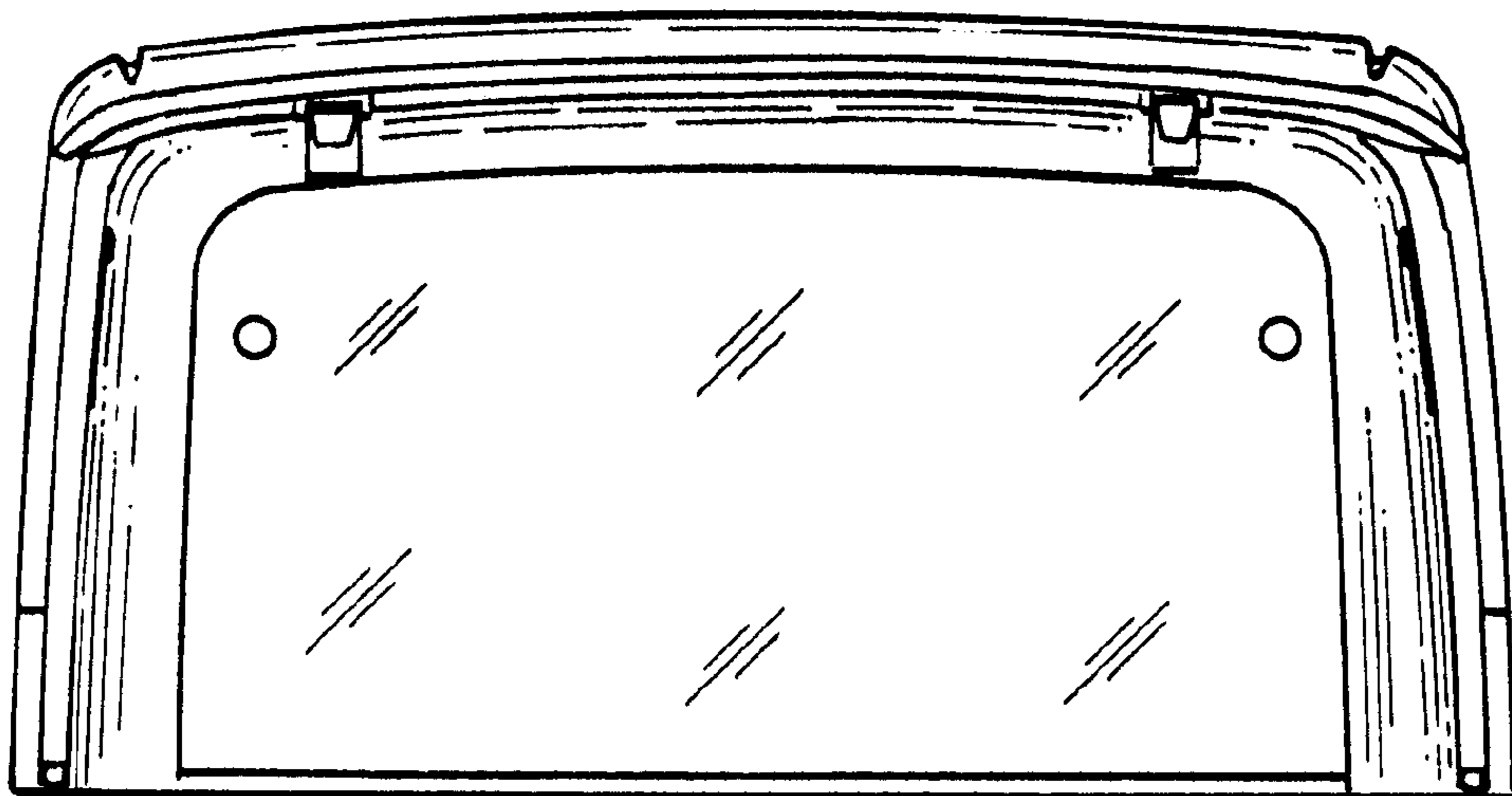

Fig. 6

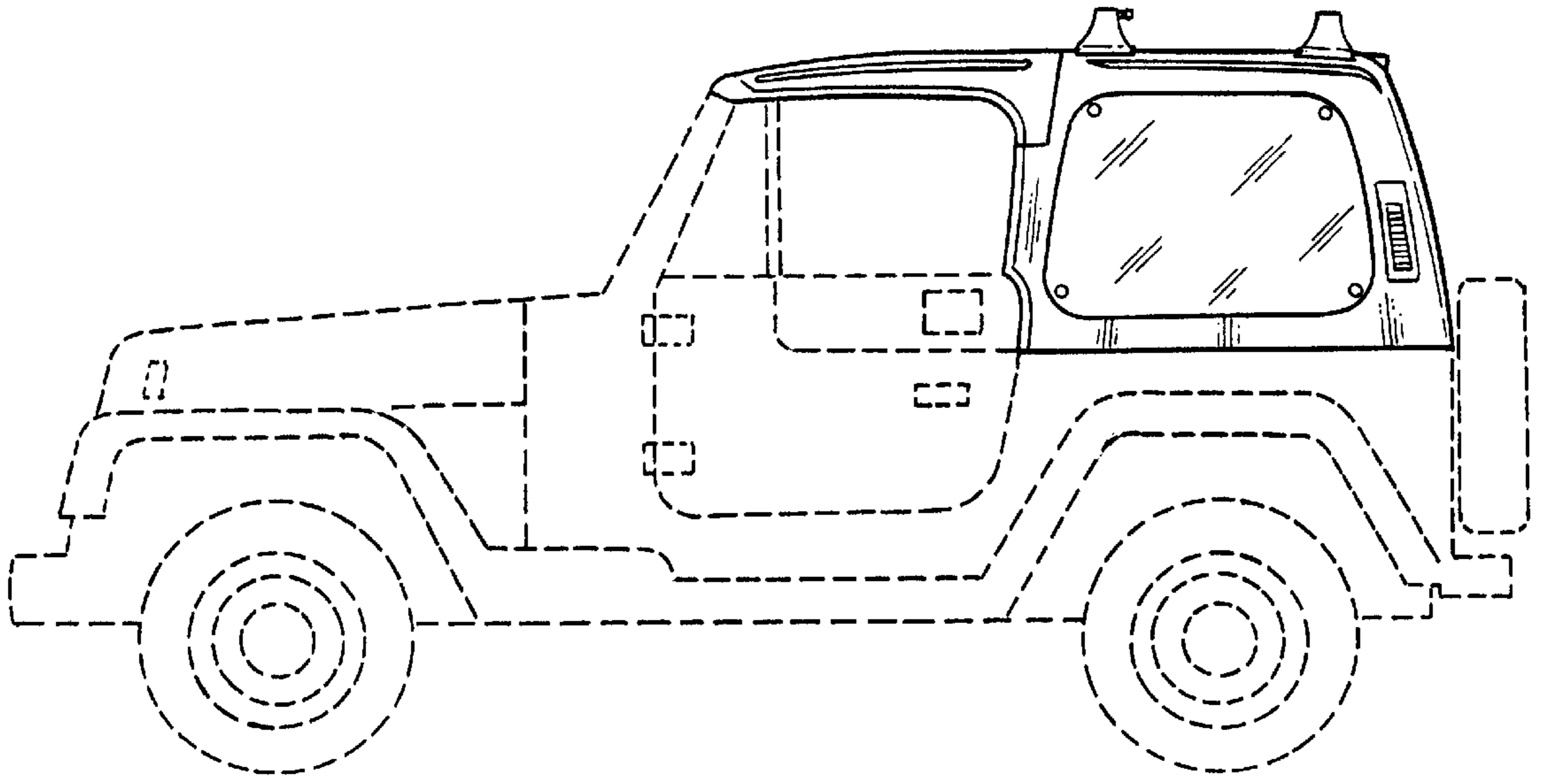

Fig. 7

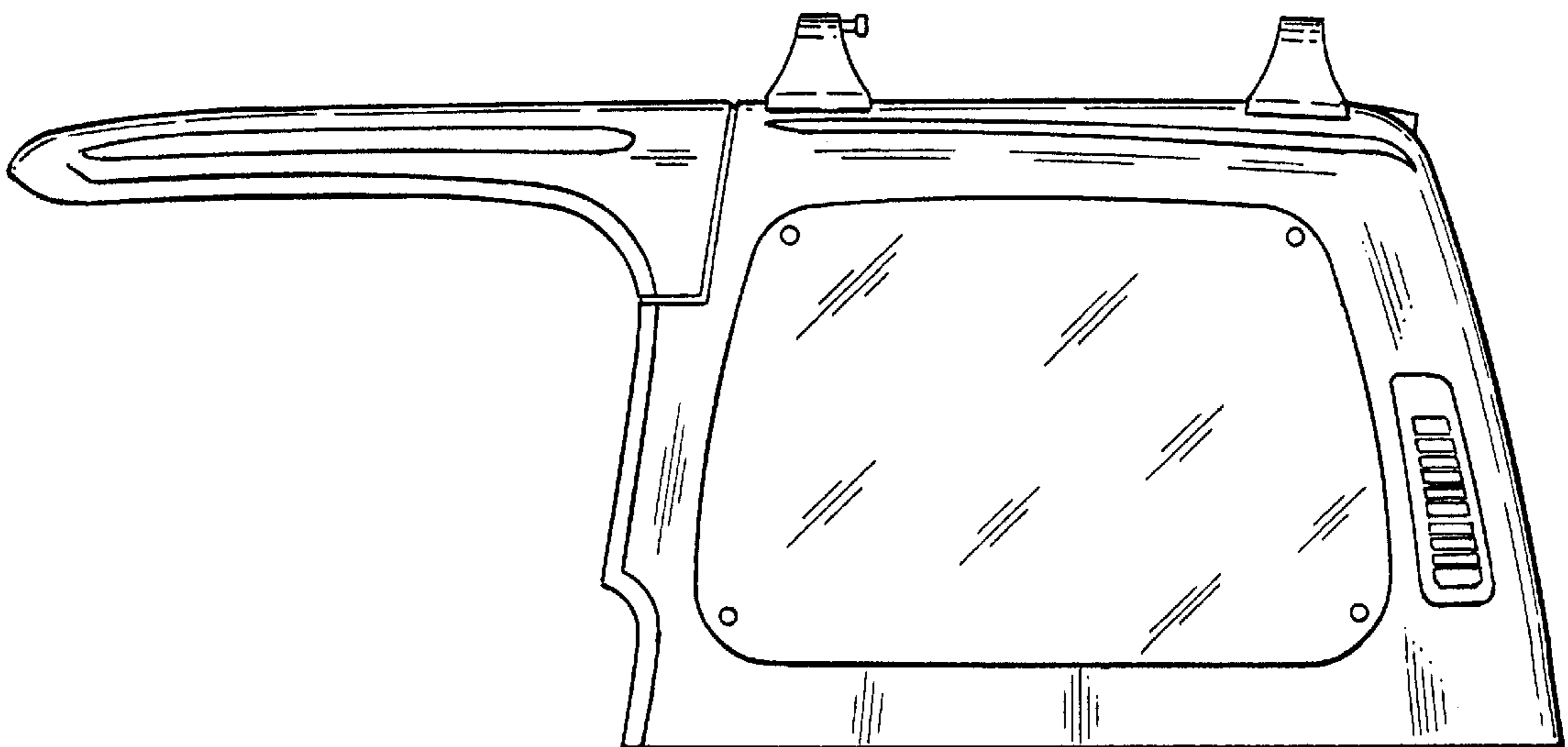

Fig. 8

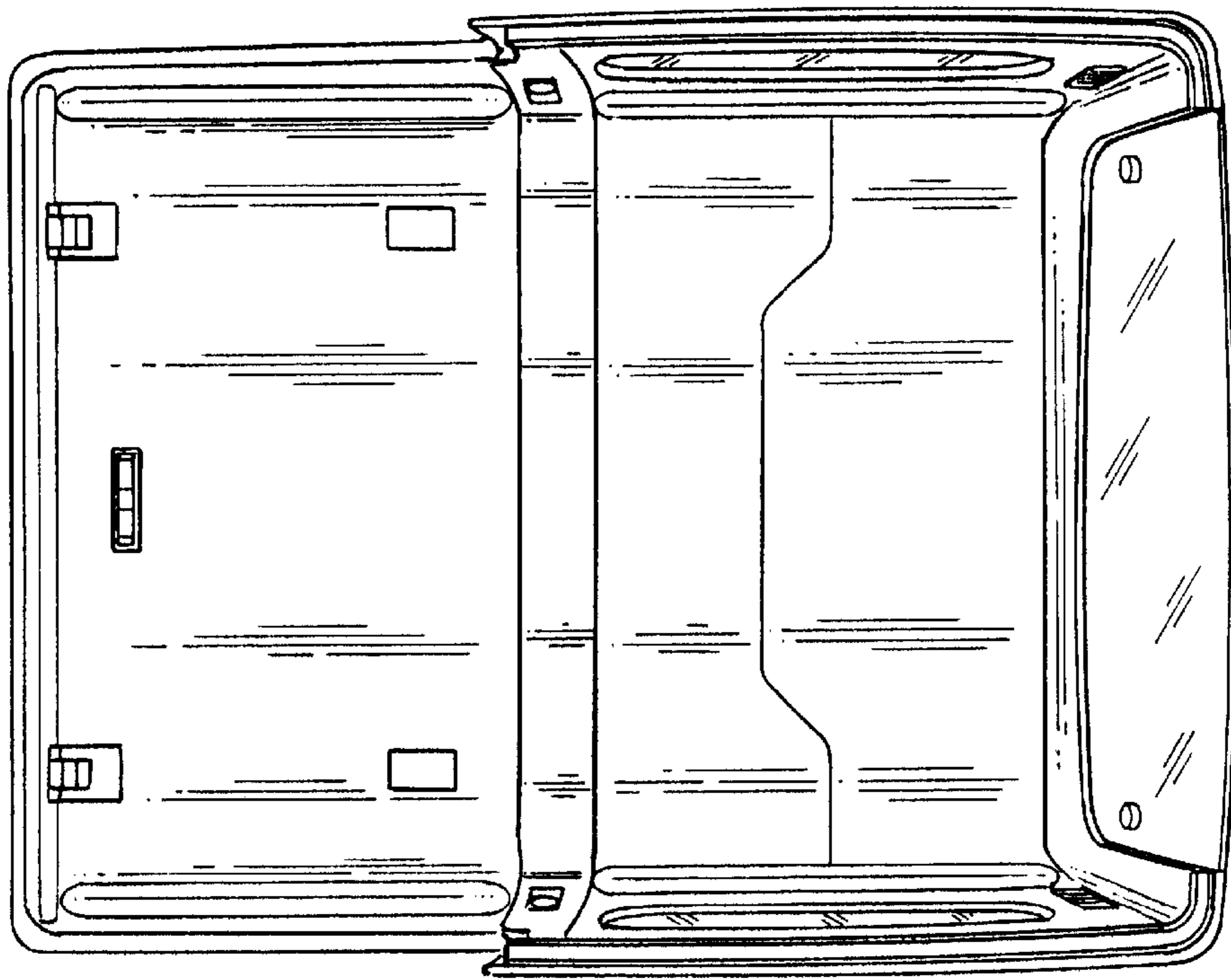

Fig. 9

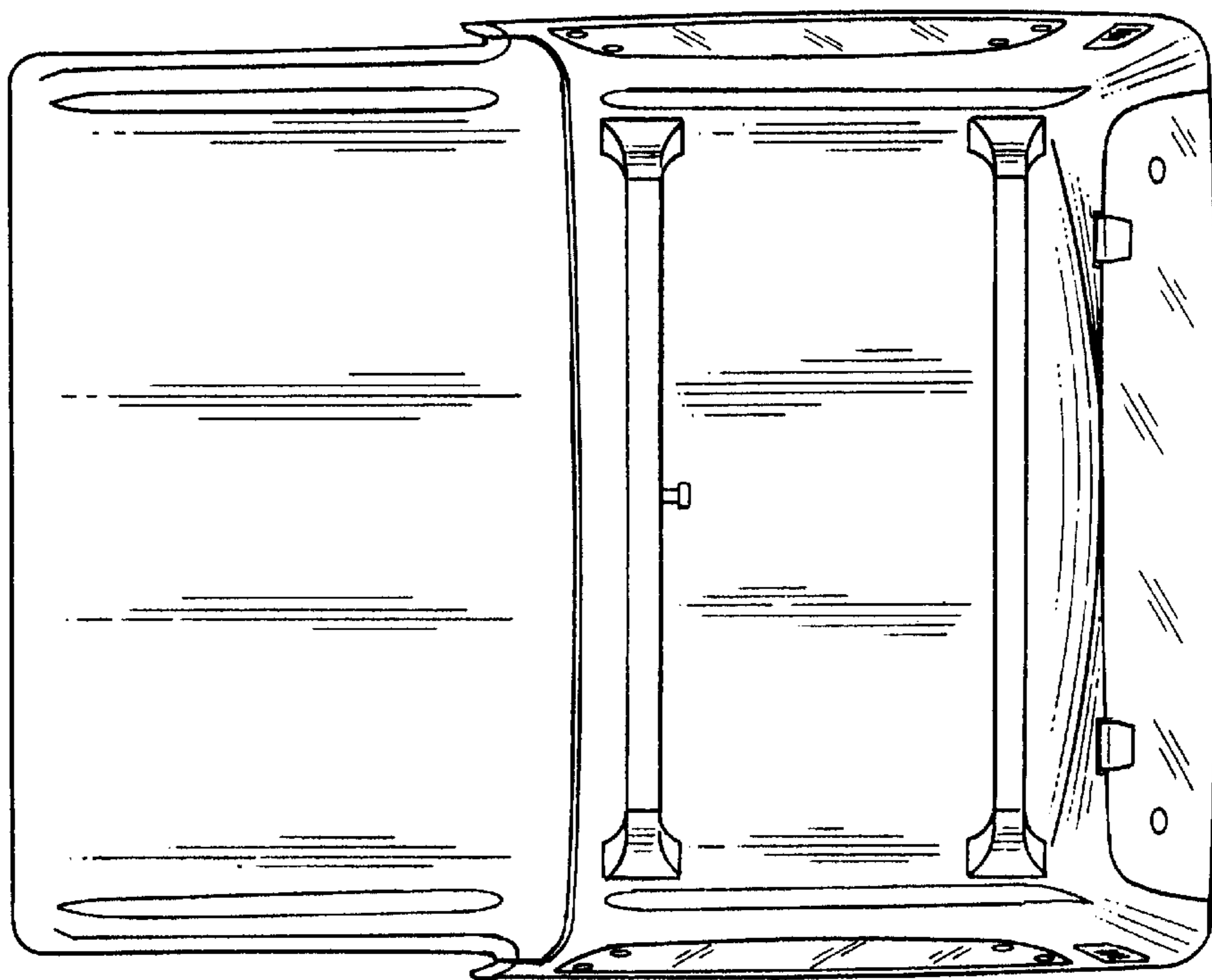

Fig. 10

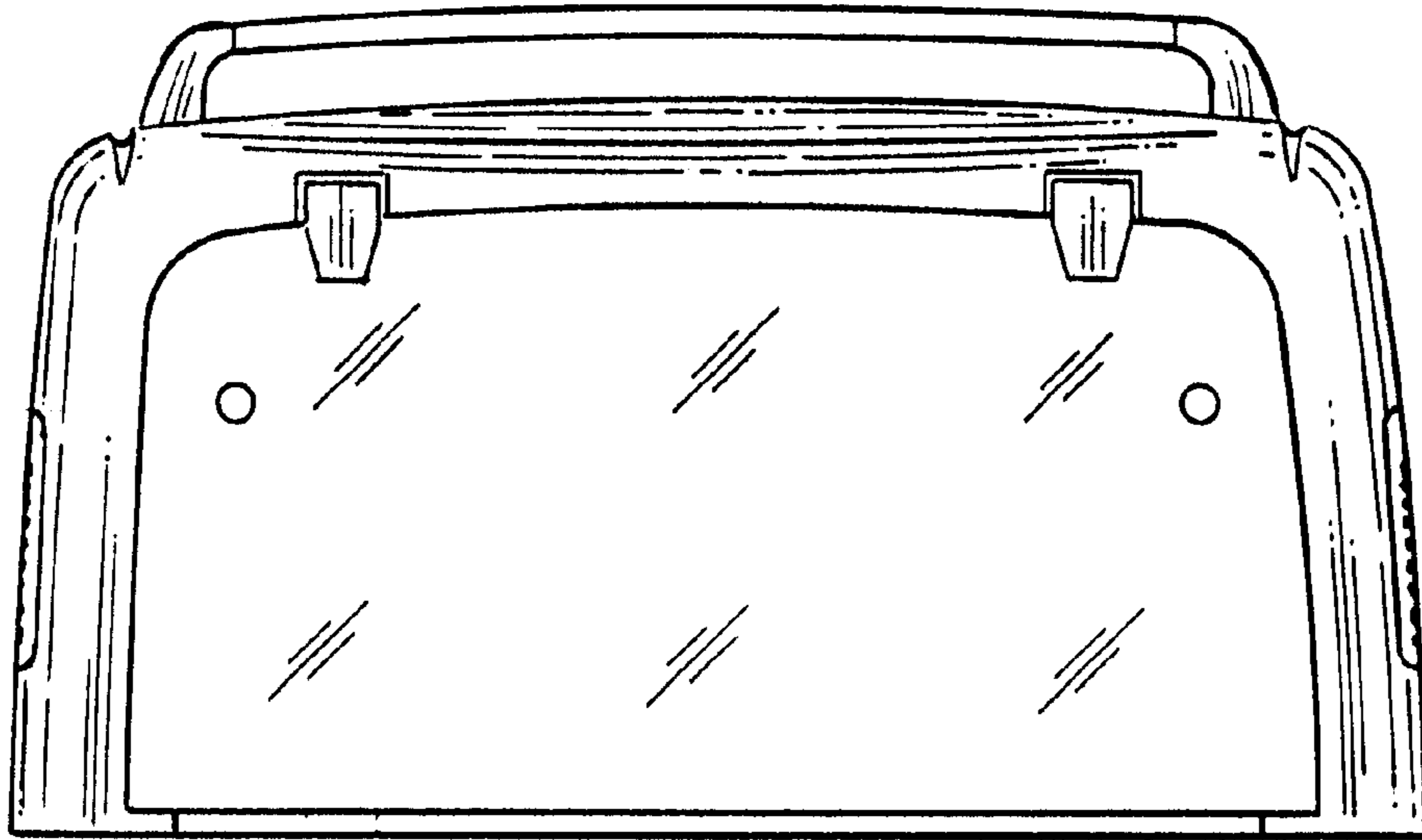

Fig. 11

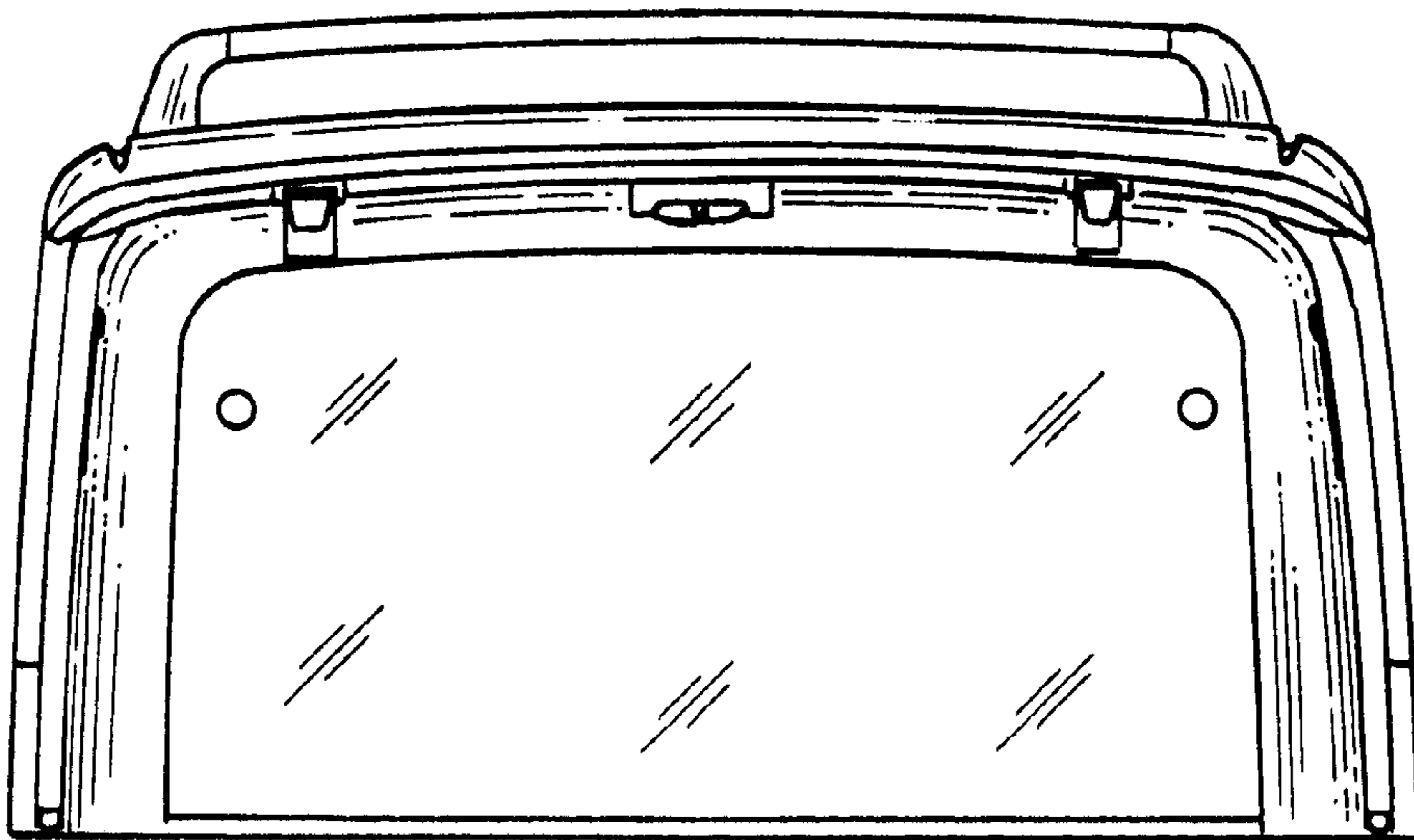

Fig. 12