



US00D442271S

(12) **United States Design Patent**
Tsukii et al.

(10) **Patent No.:** **US D442,271 S**

(45) **Date of Patent:** **** May 15, 2001**

(54) **AIR-CLEANER ELEMENT FOR AN
INTERNAL-COMBUSTION ENGINE**

(75) Inventors: **Tsutomu Tsukii; Masahiro Ishiga;
Hiroshi Ikeba**, all of Wako (JP)

(73) Assignee: **Honda Giken Kogyo Kabushiki
Kaisha**, Tokyo (JP)

(**) Term: **14 Years**

(21) Appl. No.: **29/126,952**

(22) Filed: **Jul. 28, 2000**

(30) **Foreign Application Priority Data**

Jan. 28, 2000 (JP) 001314

(51) **LOC (7) Cl.** **23-04**

(52) **U.S. Cl.** **D23/364**

(58) **Field of Search** 55/385.7, DIG. 30;
D23/365, 364

(56) **References Cited**

U.S. PATENT DOCUMENTS

5,900,032 * 5/1999 Wang 55/385.3

* cited by examiner

Primary Examiner—Lisa Lichtenstein
(74) *Attorney, Agent, or Firm*—Armstrong, Westerman,
Hattori, McLeland & Naughton, LLP

(57) **CLAIM**

The ornamental design for, an air-cleaner element for an internal-combustion engine, as shown and described.

DESCRIPTION

FIG. 1 is a front view view of an air-cleaner element for an internal-combustion engine showing our new design;

FIG. 2 is a rear view thereof;

FIG. 3 is a left side view thereof;

FIG. 4 is a right side view of thereof;

FIG. 5 is a top plan view thereof and

FIG. 6 is a bottom view thereof; and,

FIG. 7 is a perspective view thereof.

1 Claim, 6 Drawing Sheets

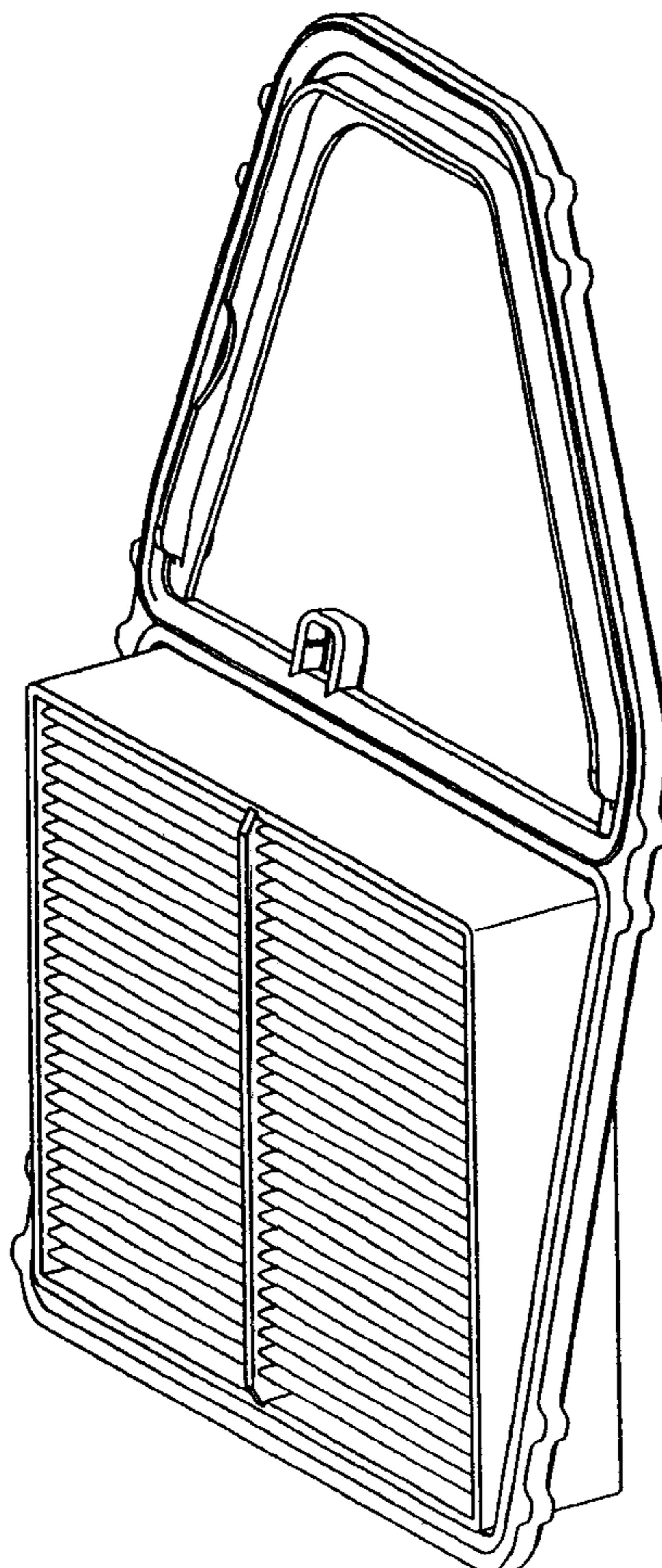

Fig. 1

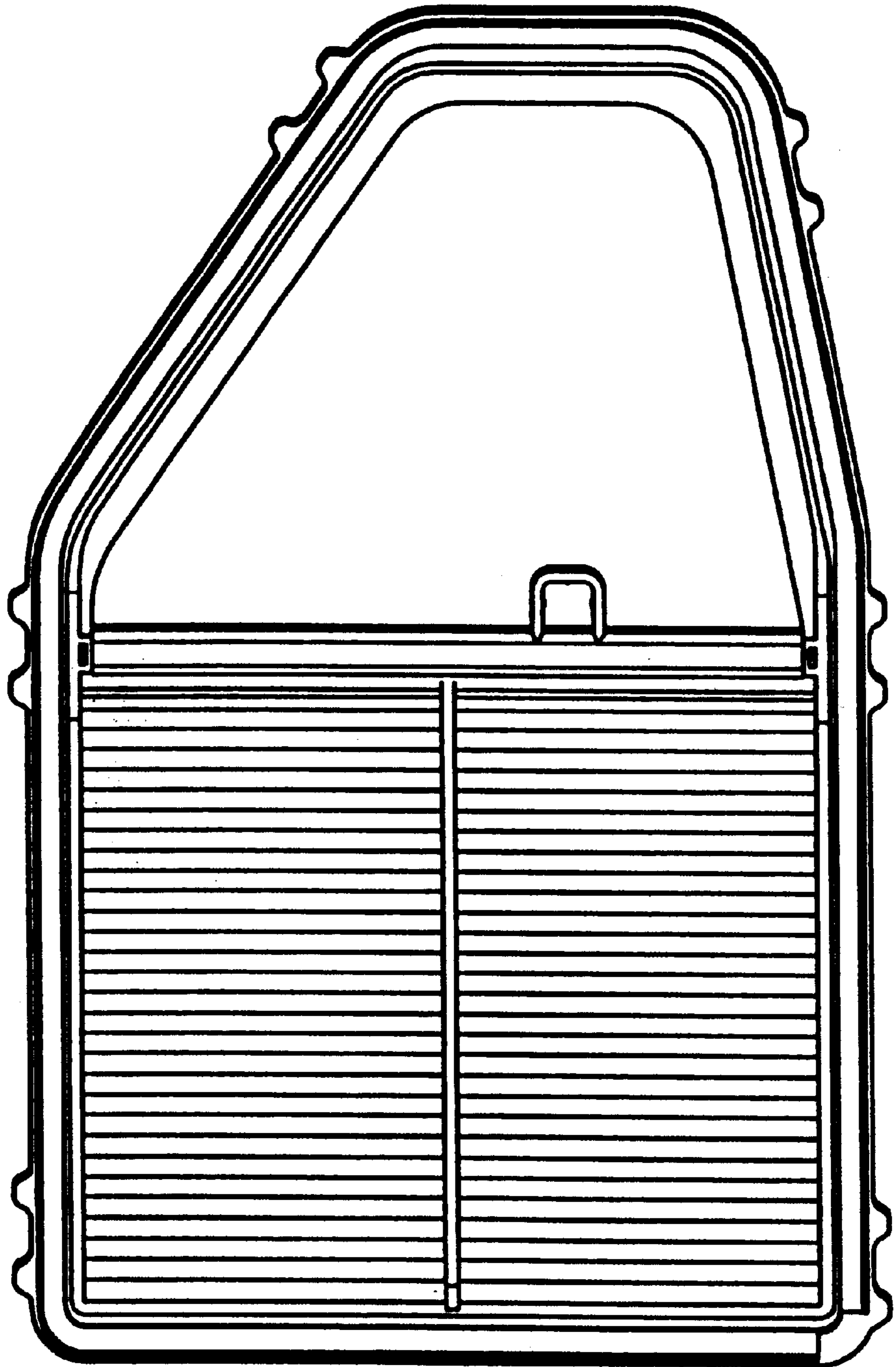

Fig. 2

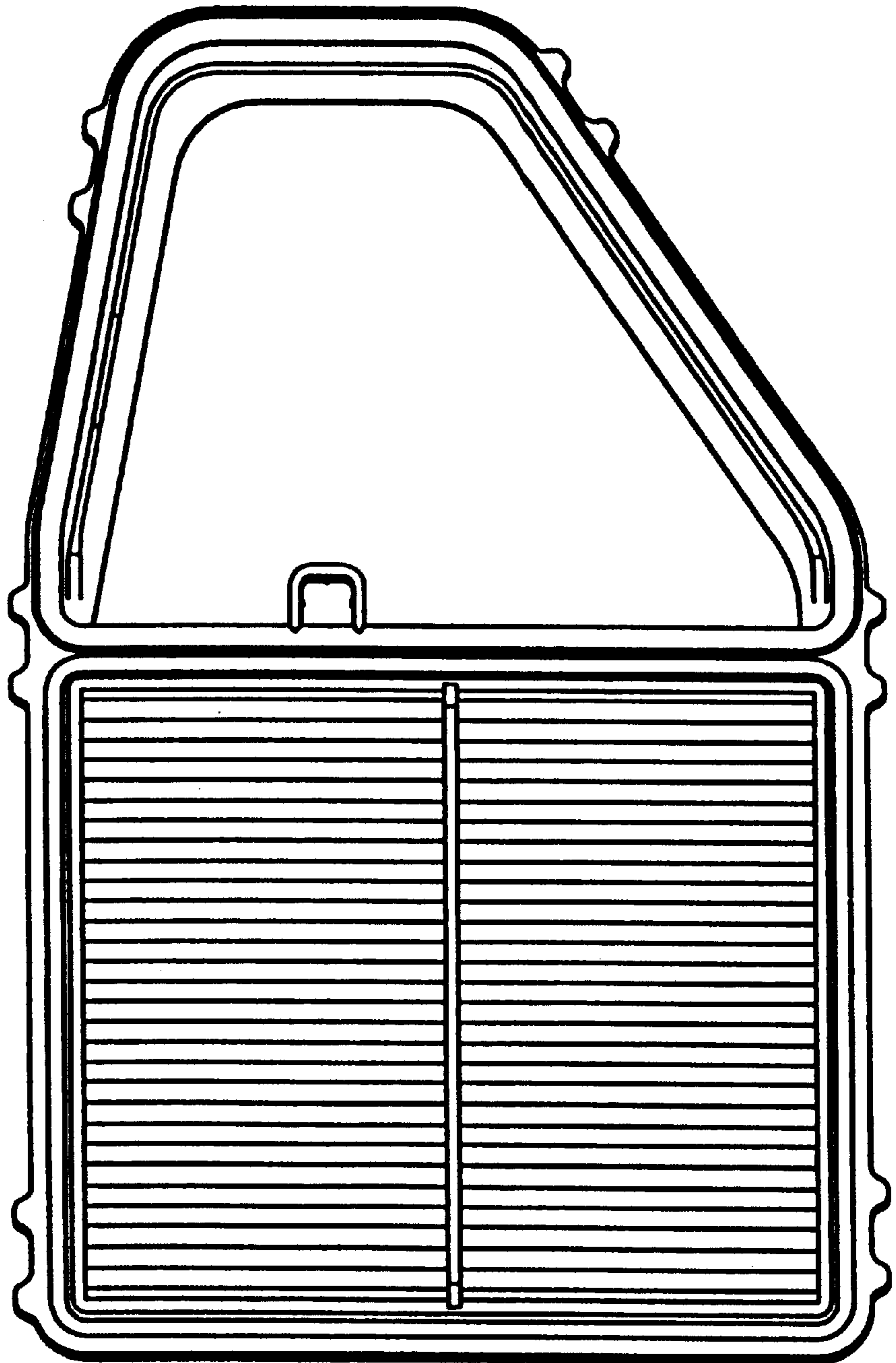

Fig. 3

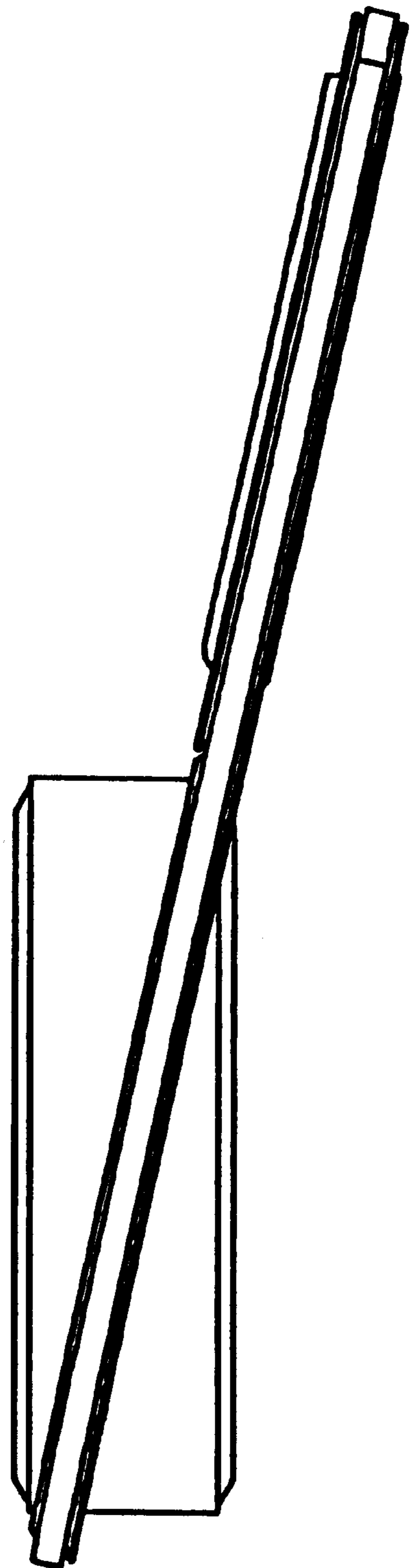

Fig. 4

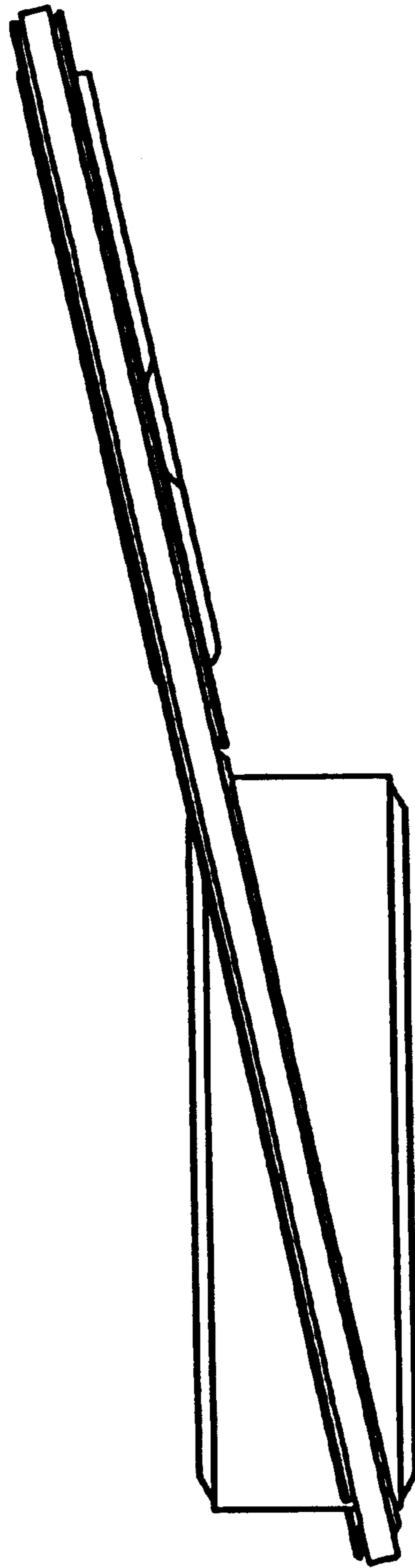

Fig. 5

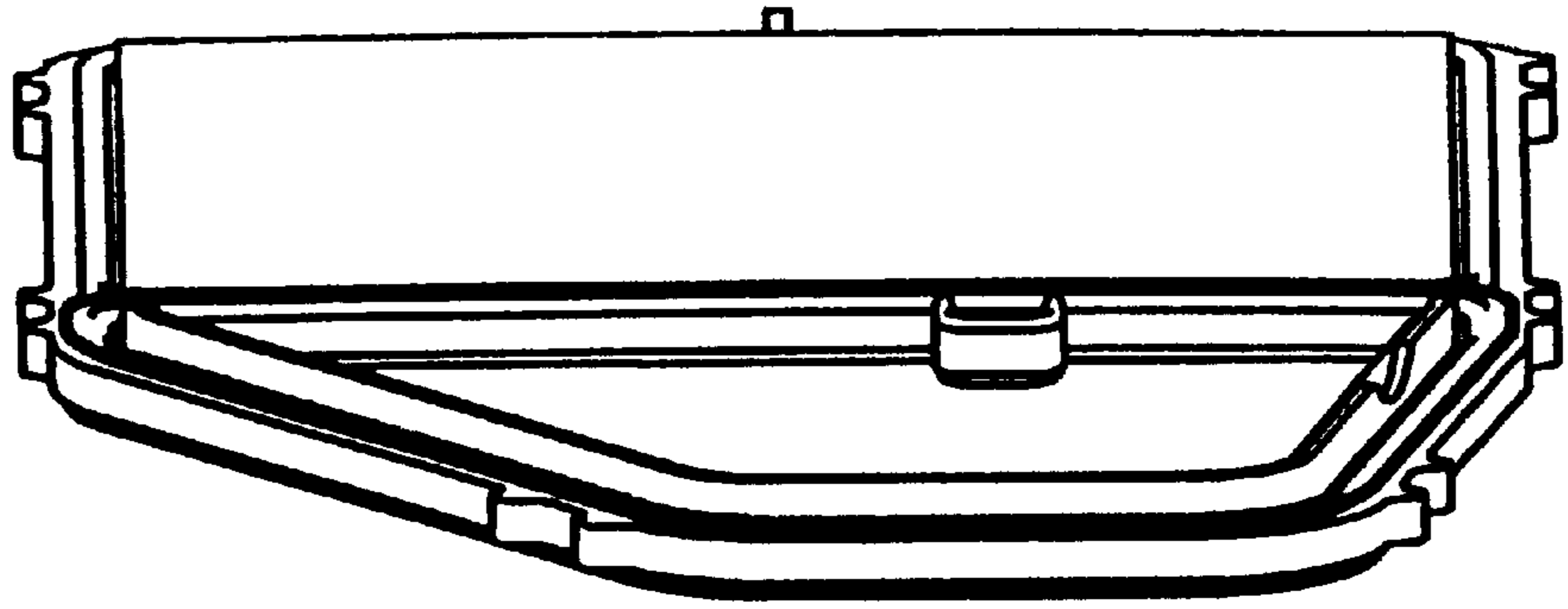

Fig. 6

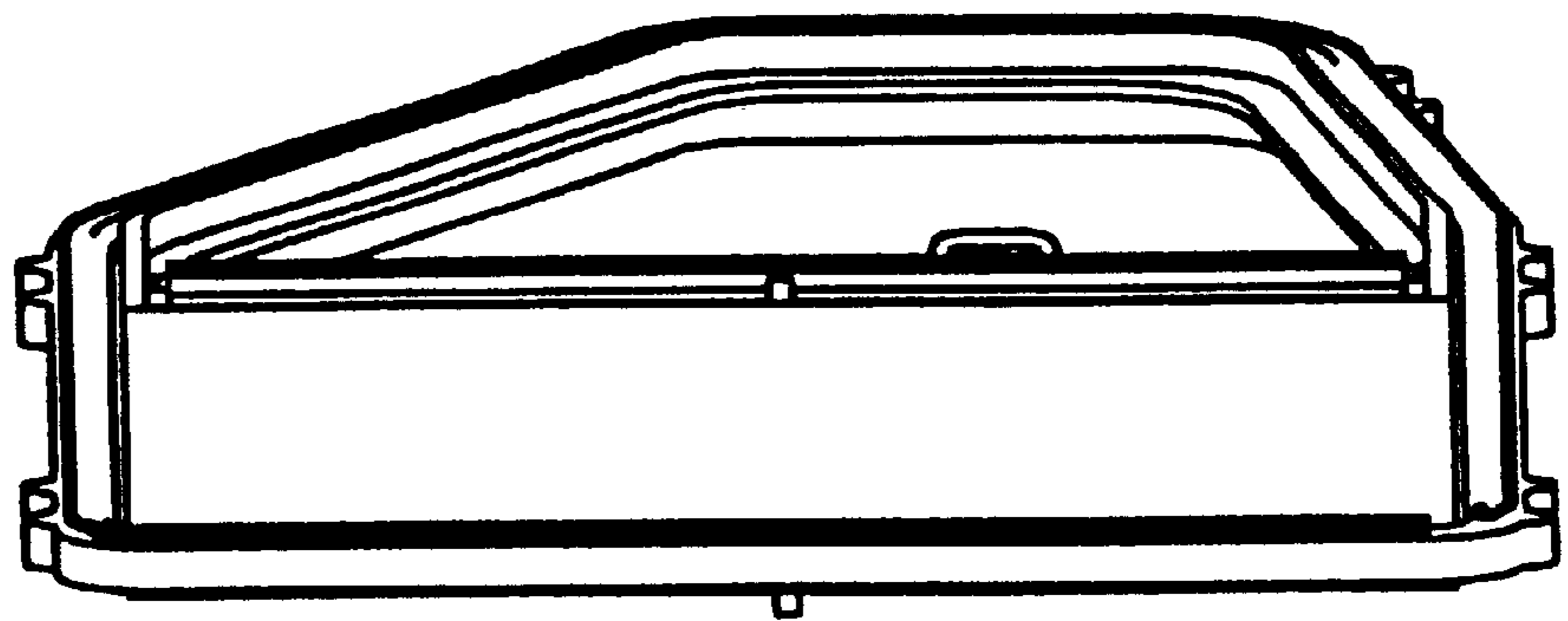

Fig. 7

