



US00D442120S

(12) **United States Design Patent**
Yeh

(10) **Patent No.:** **US D442,120 S**

(45) **Date of Patent:** **** May 15, 2001**

(54) **FRAME OF BIKE OR AUTOBIKE**

D. 398,266 * 9/1998 Colegrove et al. D12/111

* cited by examiner

(76) Inventor: **Ming-Hsin Yeh**, No. 25, Hsi-Pu 2nd St.,
Hsi-Pu Tsun, Kuei-Jen Hsiang, Tainan
Hsien (TW)

Primary Examiner—Melody N. Brown
(74) *Attorney, Agent, or Firm*—Rosenberg, Klein & Lee

(**) Term: **14 Years**

(57) **CLAIM**

The ornamental design for a frame of bike or autobike, as shown and described.

(21) Appl. No.: **29/118,095**

(22) Filed: **Feb. 4, 2000**

DESCRIPTION

(51) **LOC (7) Cl.** **12-11**

FIG. 1 is a perspective view of a frame of bike or autobike showing my present design;

(52) **U.S. Cl.** **D12/111**

FIG. 2 is a front elevational view thereof;

(58) **Field of Search** D12/111, 114,

FIG. 3 is a rear elevational view thereof;

D12/117; 280/281.1, 288.1, 288.3

FIG. 4 is a left side elevational view thereof;

FIG. 5 is a right side elevational view thereof;

(56) **References Cited**

FIG. 6 is a top plan view thereof;

U.S. PATENT DOCUMENTS

FIG. 7 is a bottom plan view, and,

D. 372,212 * 7/1996 Dietz et al. D12/111

FIG. 8 is a side cross-sectioned view thereof, taken along line 8—8 in FIG. 1.

D. 396,434 * 7/1998 Tseng D12/111

1 Claim, 6 Drawing Sheets

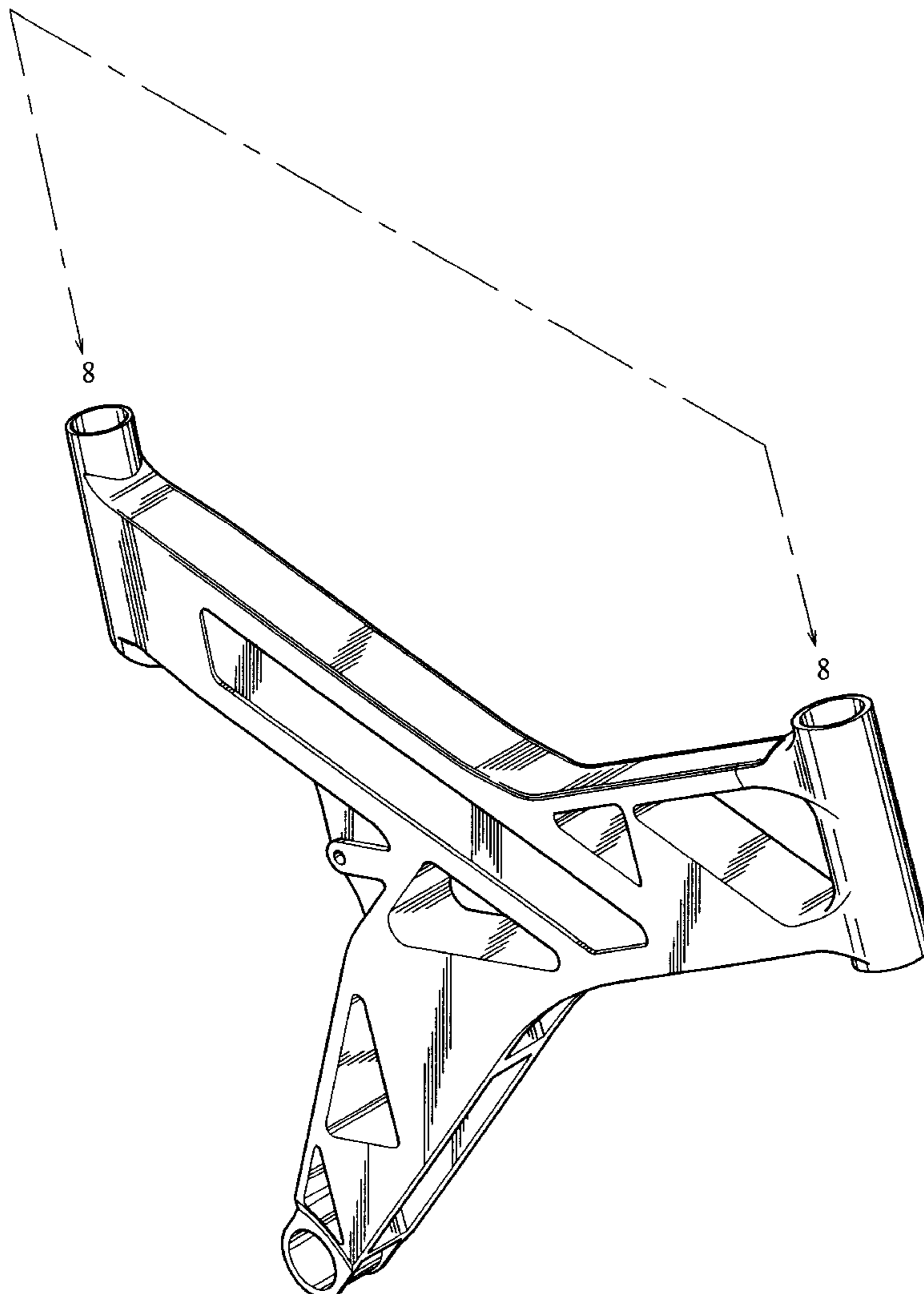

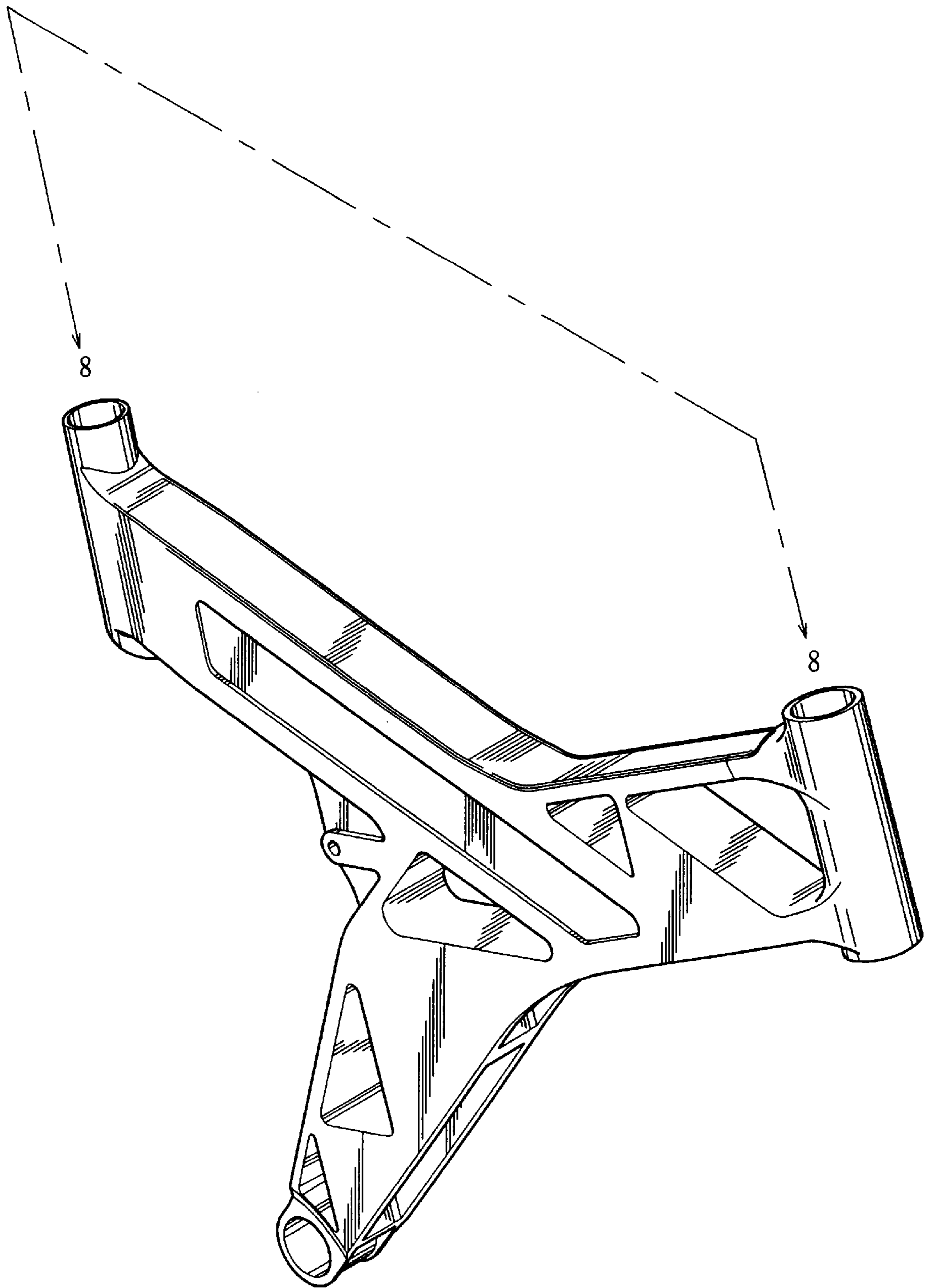

FIG. 1

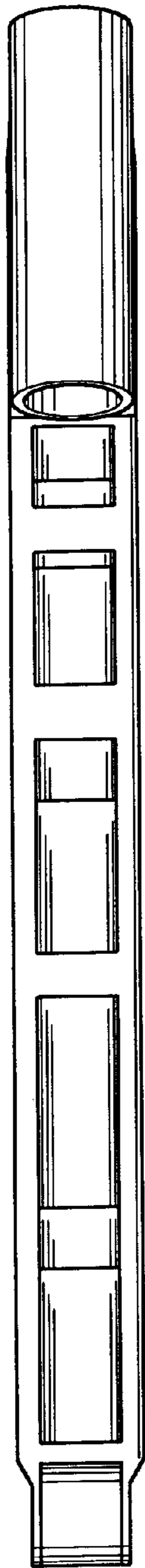

FIG. 2

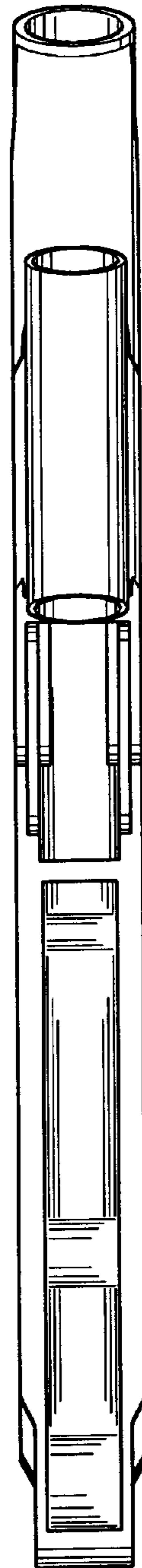

FIG. 3

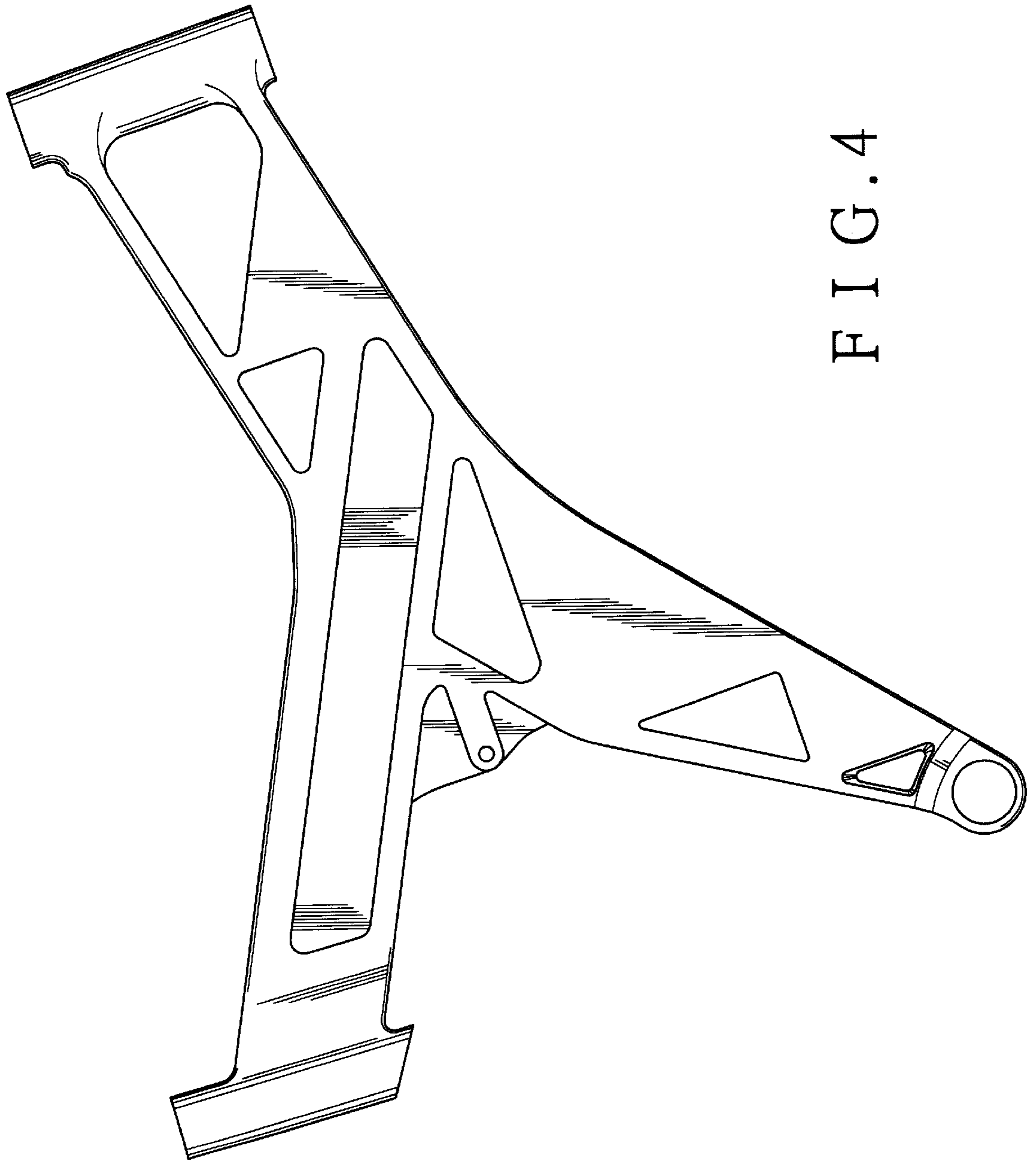

FIG. 4

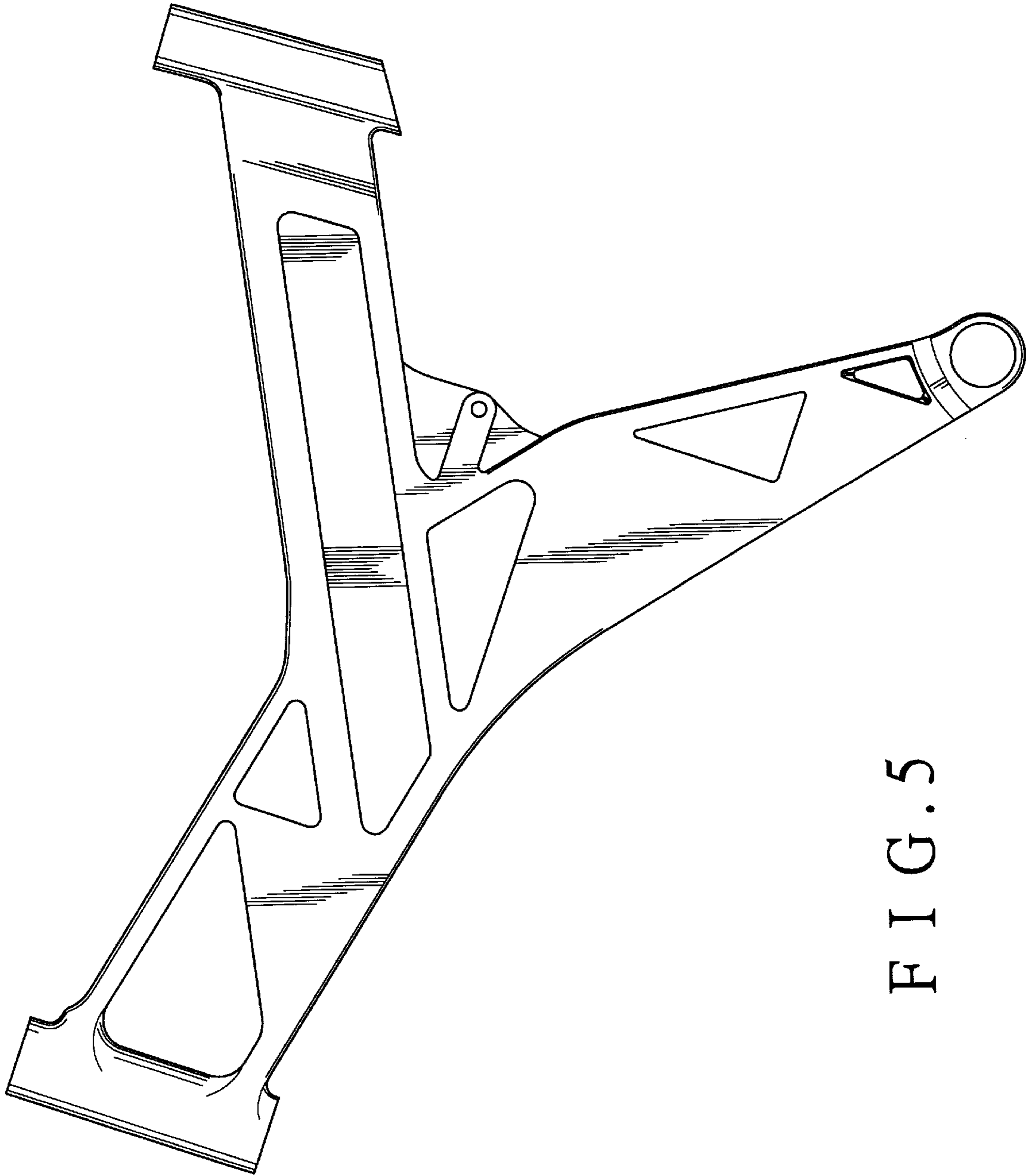

FIG. 5



FIG. 6

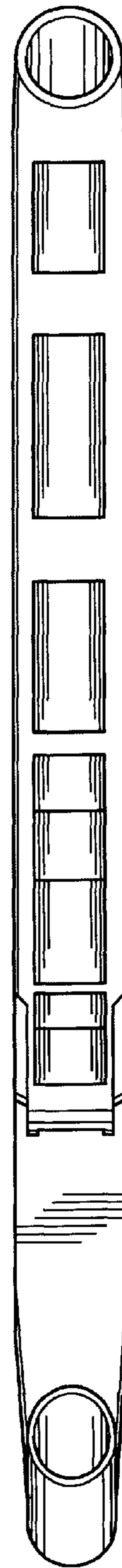

FIG. 7

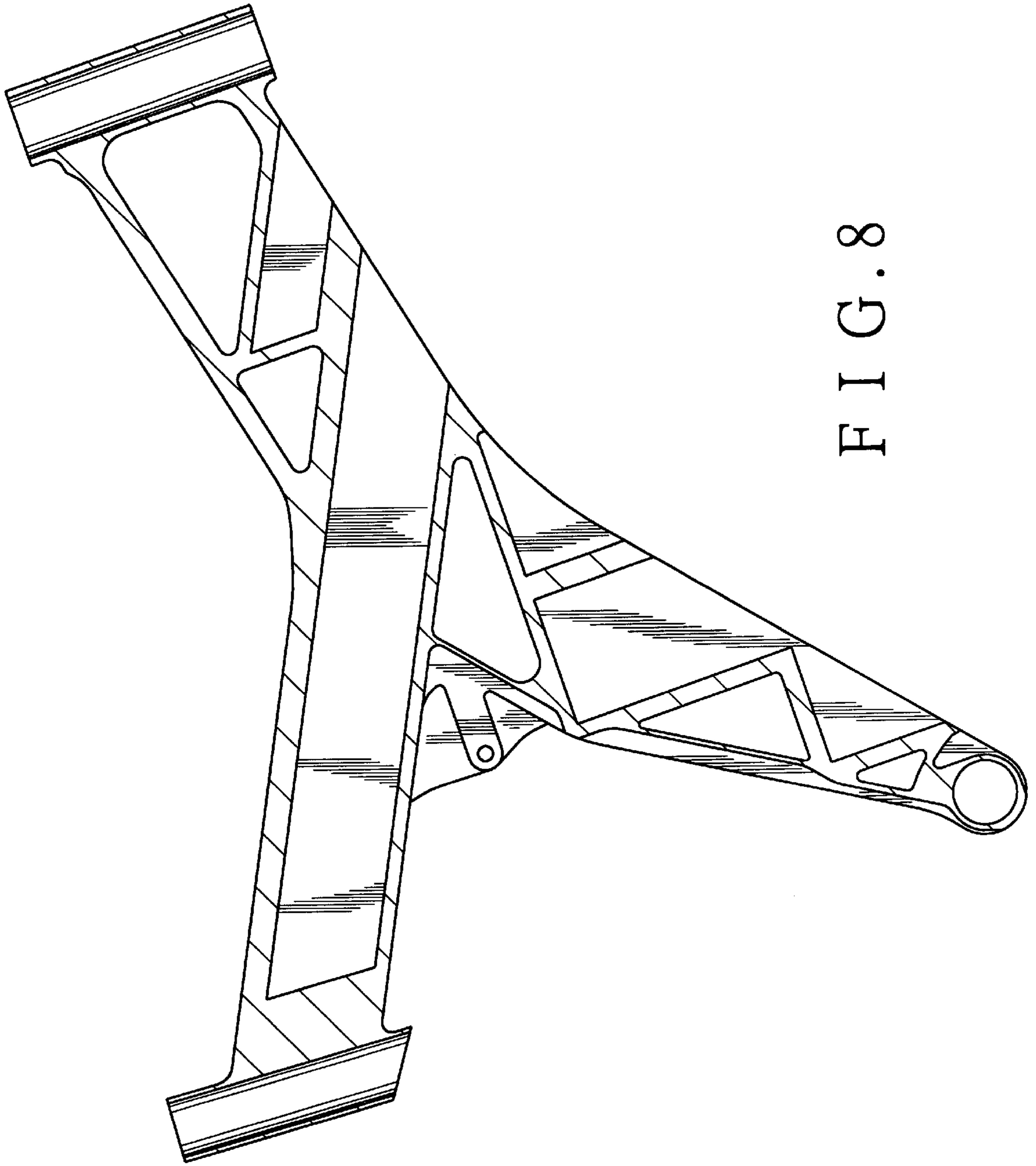

FIG. 8