



US00D442062S

(12) **United States Design Patent**
Kelley et al.

(10) **Patent No.:** **US D442,062 S**
(45) **Date of Patent:** **** May 15, 2001**

(54) **DETACHABLE CARGO BRACKET**

DESCRIPTION

(76) Inventors: **Cynthia H. Kelley; Ralph Kelley**, both of 15 Sundance Dr., Phillips Ranch, CA (US) 91766

(**) Term: **14 Years**

(21) Appl. No.: **29/114,457**

(22) Filed: **Nov. 22, 1999**

(51) **LOC (7) Cl.** **08-05**

(52) **U.S. Cl.** **D8/349**

(58) **Field of Search** D8/349, 354, 380-381; D12/223; 248/235, 237, 243, 247

(56) **References Cited**

U.S. PATENT DOCUMENTS

- D. 247,550 * 3/1978 Filice D32/54
- D. 335,815 * 5/1993 Sachs D8/363
- D. 392,933 * 3/1998 Mattila D12/223
- 4,325,528 * 4/1982 Martin 248/217.2

* cited by examiner

Primary Examiner—Holly Baynham

(74) *Attorney, Agent, or Firm*—Christie, Parker & Hale, LLP

(57) **CLAIM**

The ornamental design for a detachable cargo bracket, as shown and described.

FIG. 1 is a bottom perspective view of a first embodiment of the detachable cargo bracket of the invention.

FIG. 2 is a bottom plan view of detachable cargo bracket of FIG. 1.

FIG. 3 is right side view of the detachable cargo bracket of FIG. 1.

FIG. 4 is a rear view of the detachable cargo bracket of FIG. 1; and,

FIG. 5 is a front view of the detachable cargo bracket of FIG. 1.

The left side view of the detachable cargo bracket of FIG. 1 (not shown) is a mirror image of the right side view of the detachable cargo bracket of FIG. 5.

The upper rear perspective view of the second embodiment of the detachable cargo bracket of the invention (not shown) is as shown in FIG. 1 of the first embodiment of the detachable cargo bracket of the invention.

The top plan view of the second embodiment of the detachable cargo bracket of FIG. 8 (not shown) is as shown in FIG. 1 of the first embodiment of the detachable cargo bracket of the invention.

The left side view of the detachable cargo bracket of FIG. 8 (not shown) is a mirror image of the right side view of the detachable cargo bracket of FIG. 10.

The bottom view of the detachable cargo bracket of FIG. 13 (not shown) is as shown in the first embodiment of the detachable cargo bracket of FIG. 3.

1 Claim, 3 Drawing Sheets

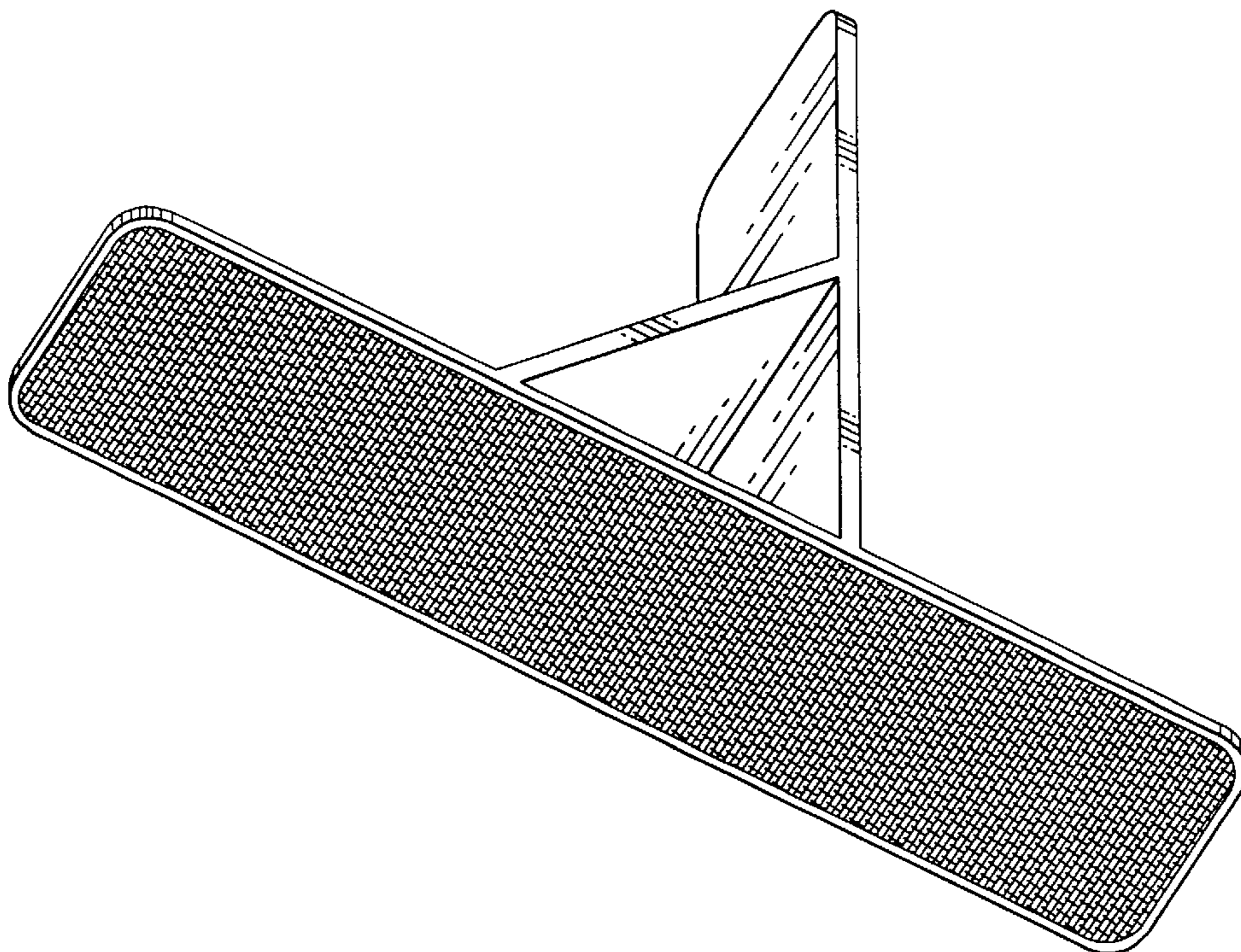

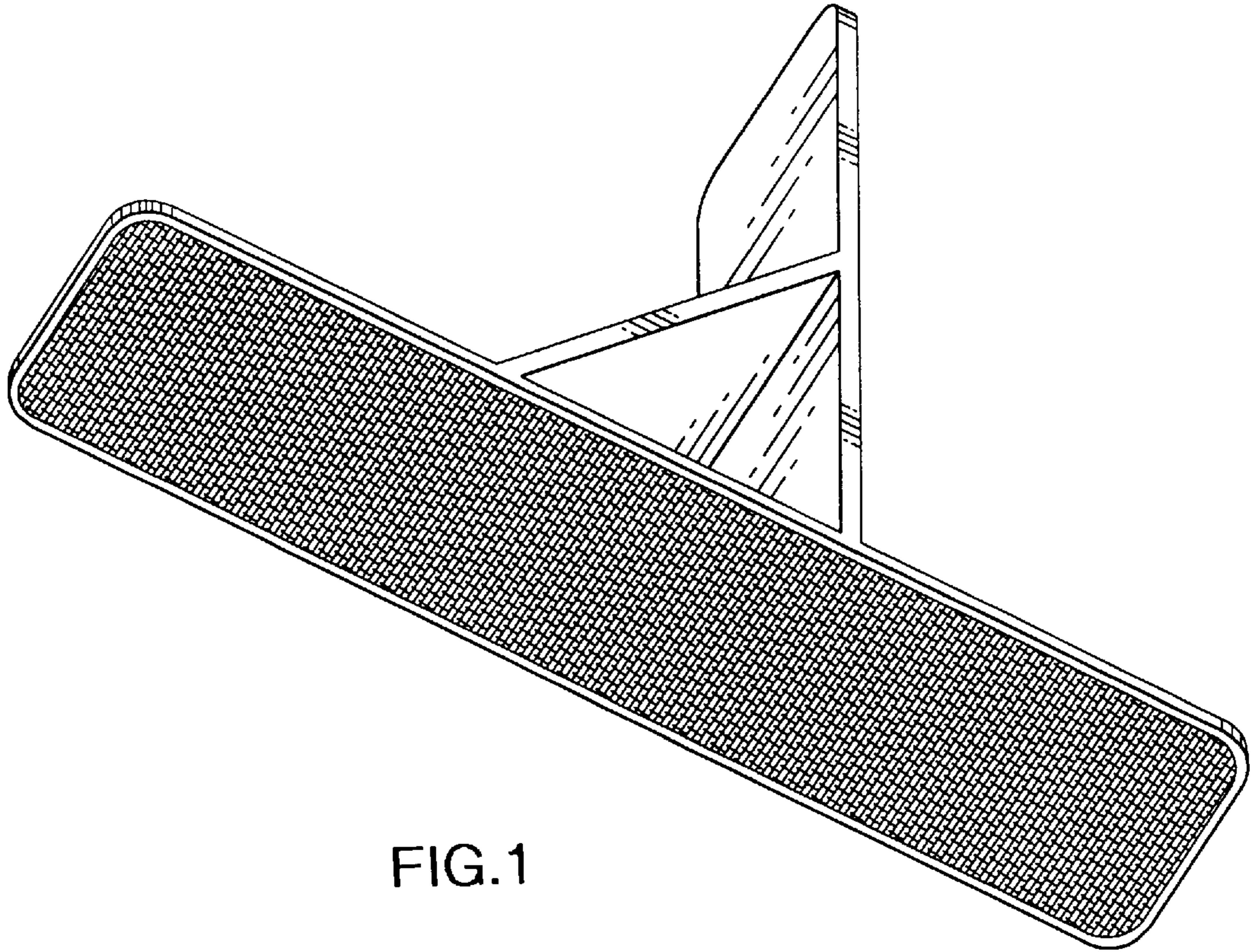

FIG. 1

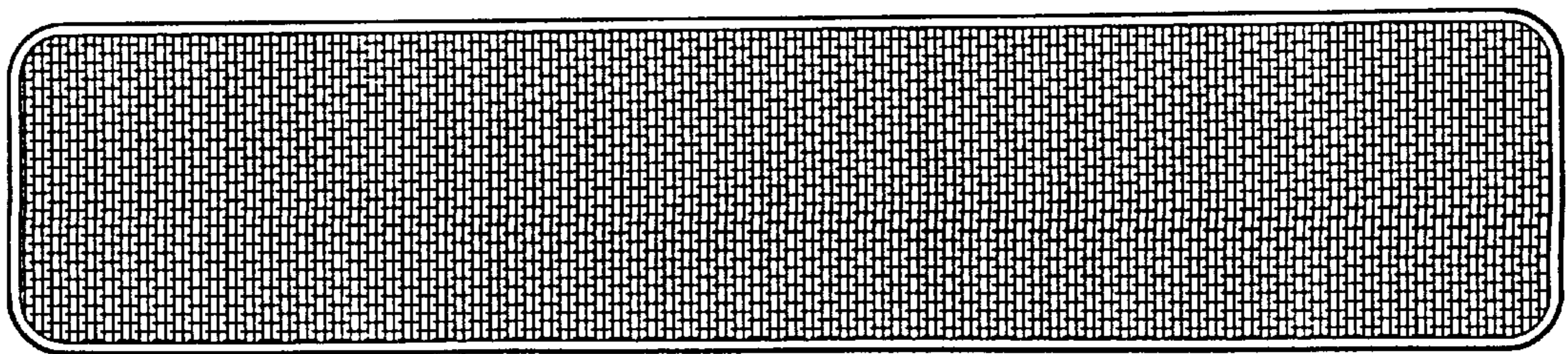

FIG. 2

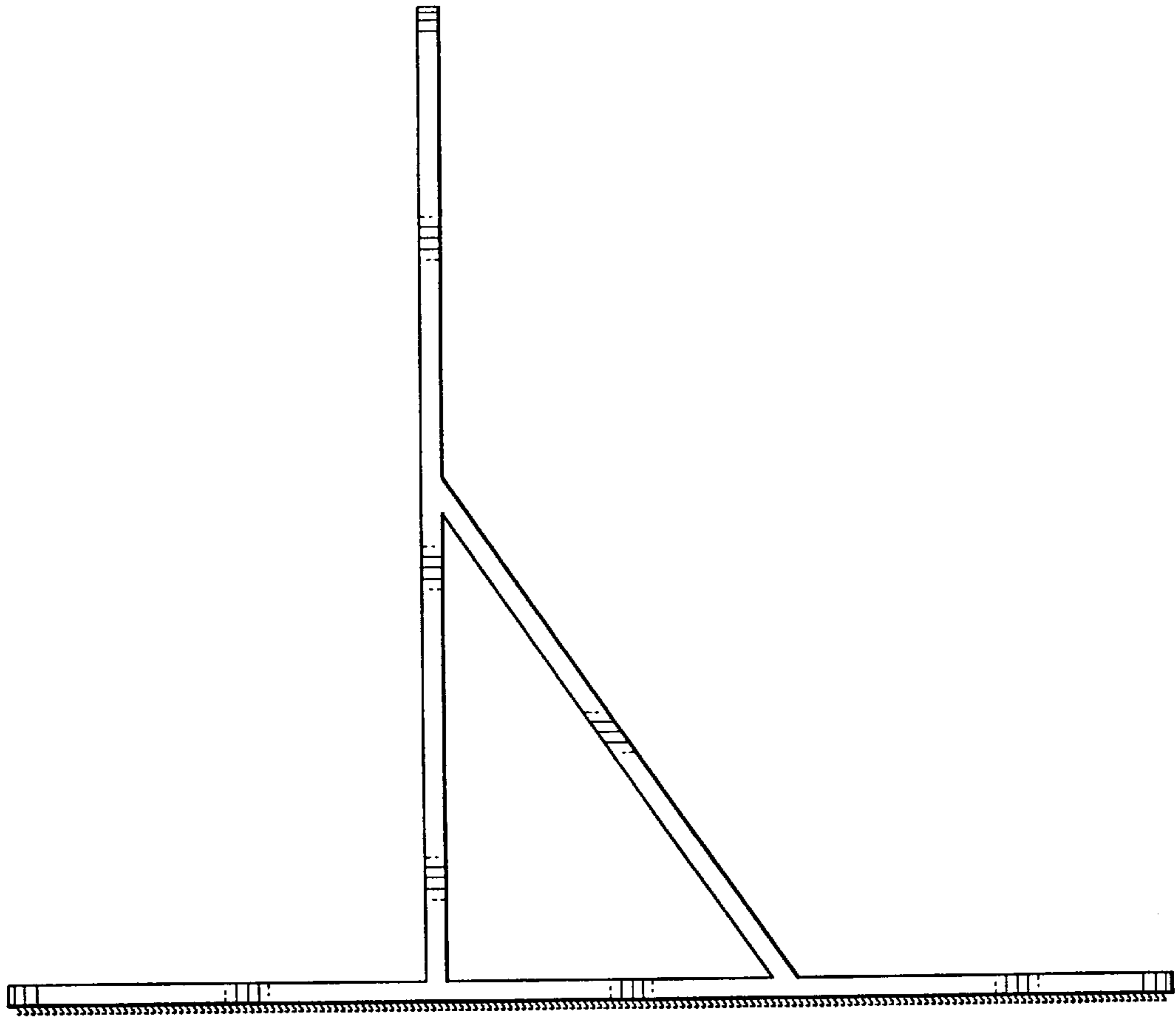

FIG. 3

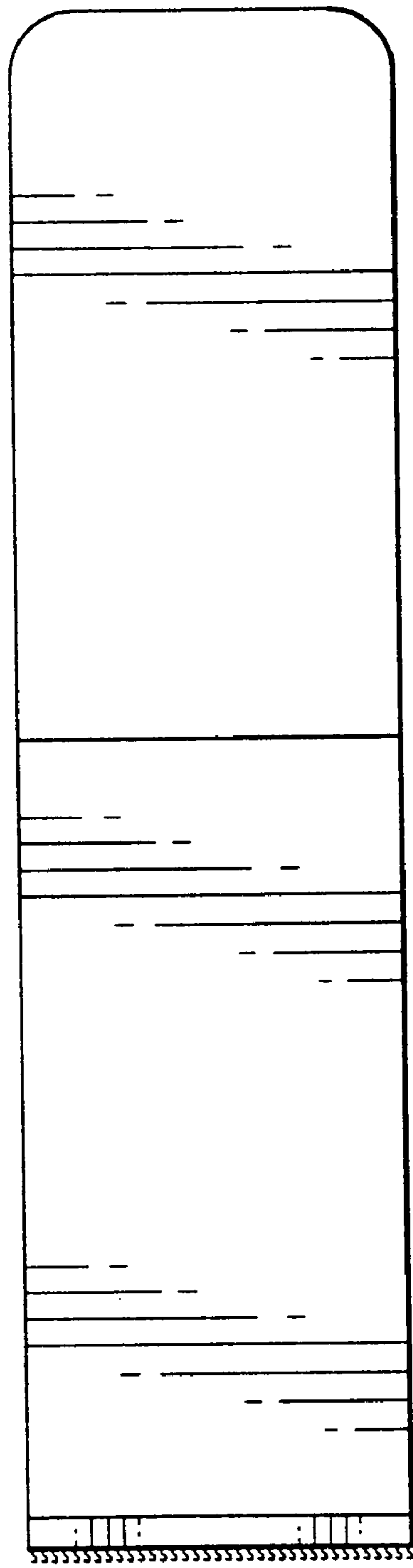

FIG. 4

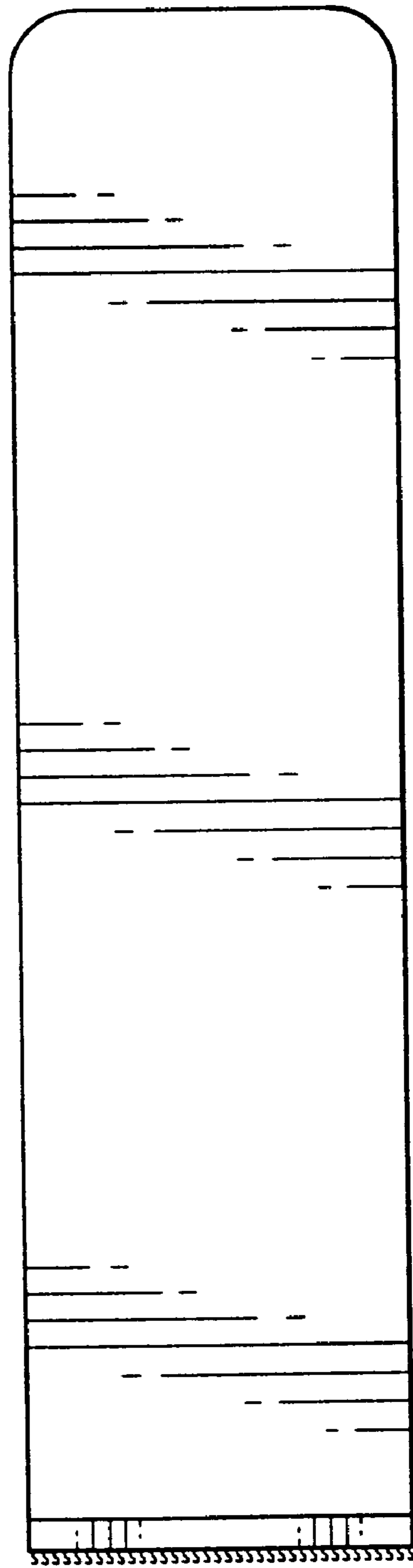

FIG. 5