



US00D442055S

(12) **United States Design Patent**  
**Dewald et al.**

(10) **Patent No.:** **US D442,055 S**

(45) **Date of Patent:** **\*\* May 15, 2001**

(54) **PULL**

(75) Inventors: **Kevin Dewald**, Spring Lake, MI (US);  
**Carl Hedrick**, Kernersville, NC (US)

(73) Assignee: **Belwith International, Ltd.**,  
Grandville, MI (US)

(\*\*) Term: **14 Years**

(21) Appl. No.: **29/092,260**

(22) Filed: **Aug. 14, 1998**

(51) **LOC (7) Cl.** ..... **08-06**

(52) **U.S. Cl.** ..... **D8/310**

(58) **Field of Search** ..... D8/300, 307, 310,  
D8/313, 315-20, 350, 352, 353; 16/110 R,  
111 R, 121, 124, 402; 292/347, 352

(56) **References Cited**

**U.S. PATENT DOCUMENTS**

- D. 71,901 \* 1/1927 Brock .
- D. 98,439 \* 2/1936 Martin .
- D. 102,023 \* 11/1936 Adams .
- D. 103,324 \* 2/1937 Jones .
- D. 121,562 \* 7/1940 Borchers .
- D. 201,121 \* 5/1965 Heyer .
- D. 227,855 \* 7/1973 Tegner .
- D. 297,211 \* 8/1988 Rhoades .

**OTHER PUBLICATIONS**

Jaybee/Ajax Cat.; p. 13; knob 5324, 1987.\*  
Belwith Cat; No. 687; p. 13; knob. P407 3.\*  
Belwith Cat.; No. 687; p. 10, pull P 251 & hinge plate P 295.\*

\* cited by examiner

*Primary Examiner*—B. J. Bullock

(74) *Attorney, Agent, or Firm*—Rader, Fishman & Grauer PLLC

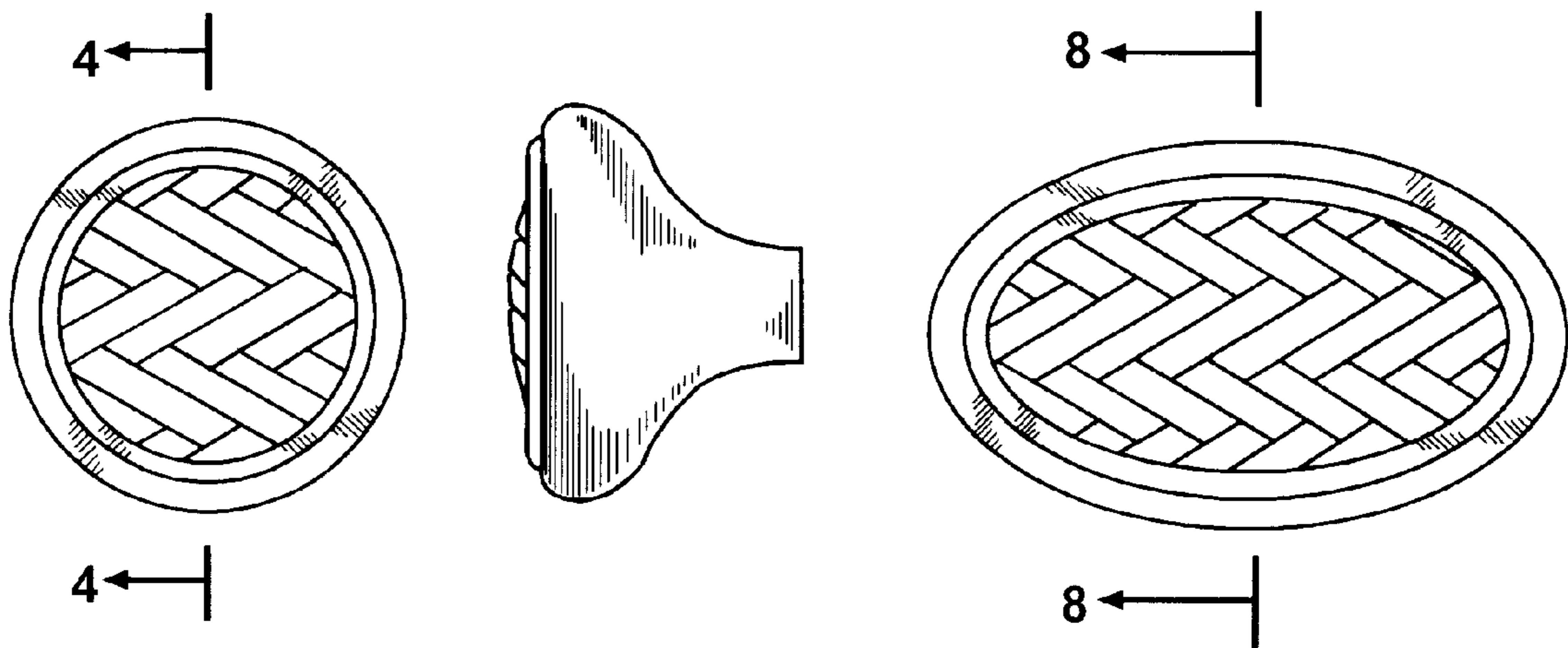
(57) **CLAIM**

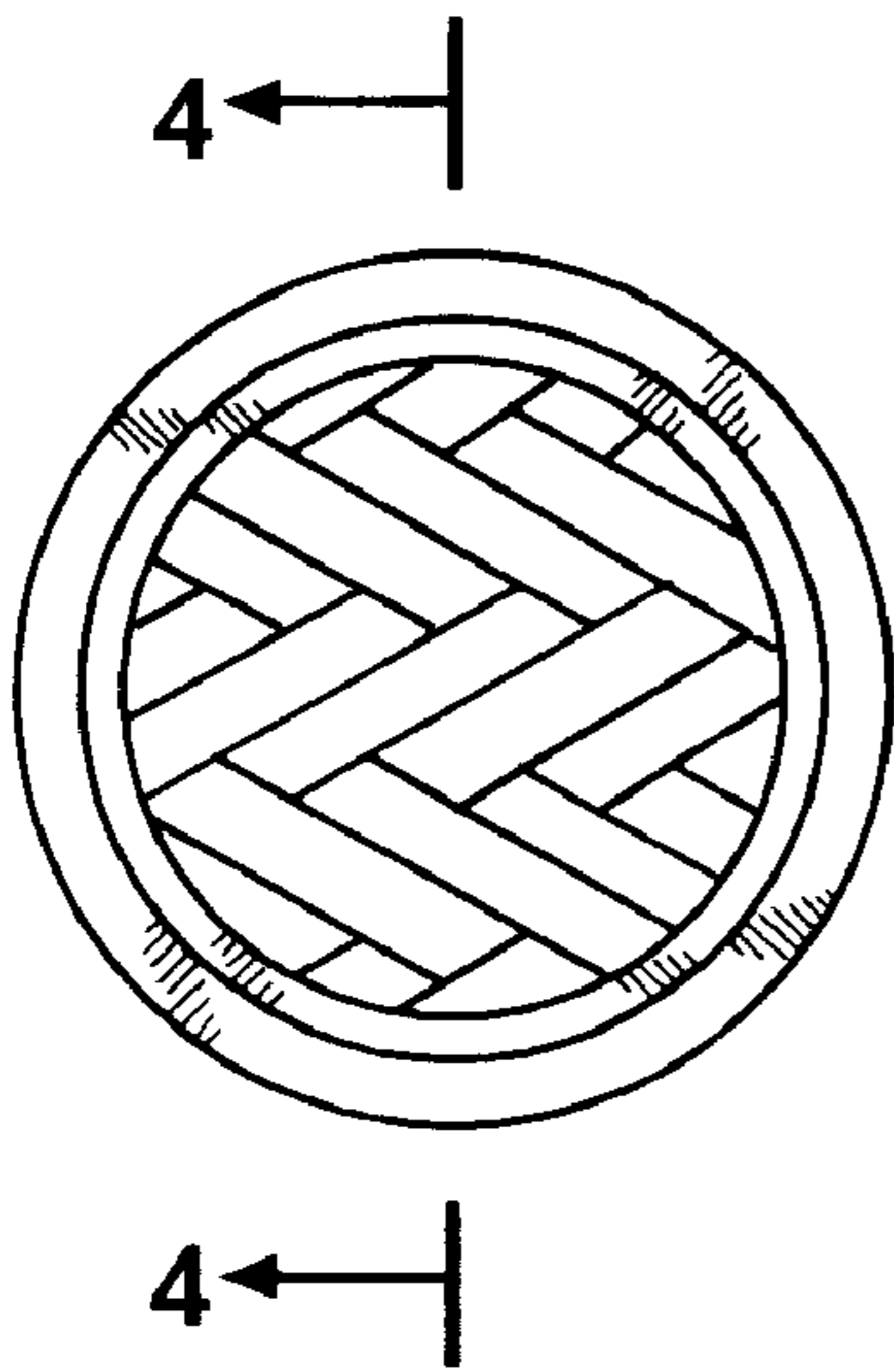
The ornamental design for a pull, as shown and described.

**DESCRIPTION**

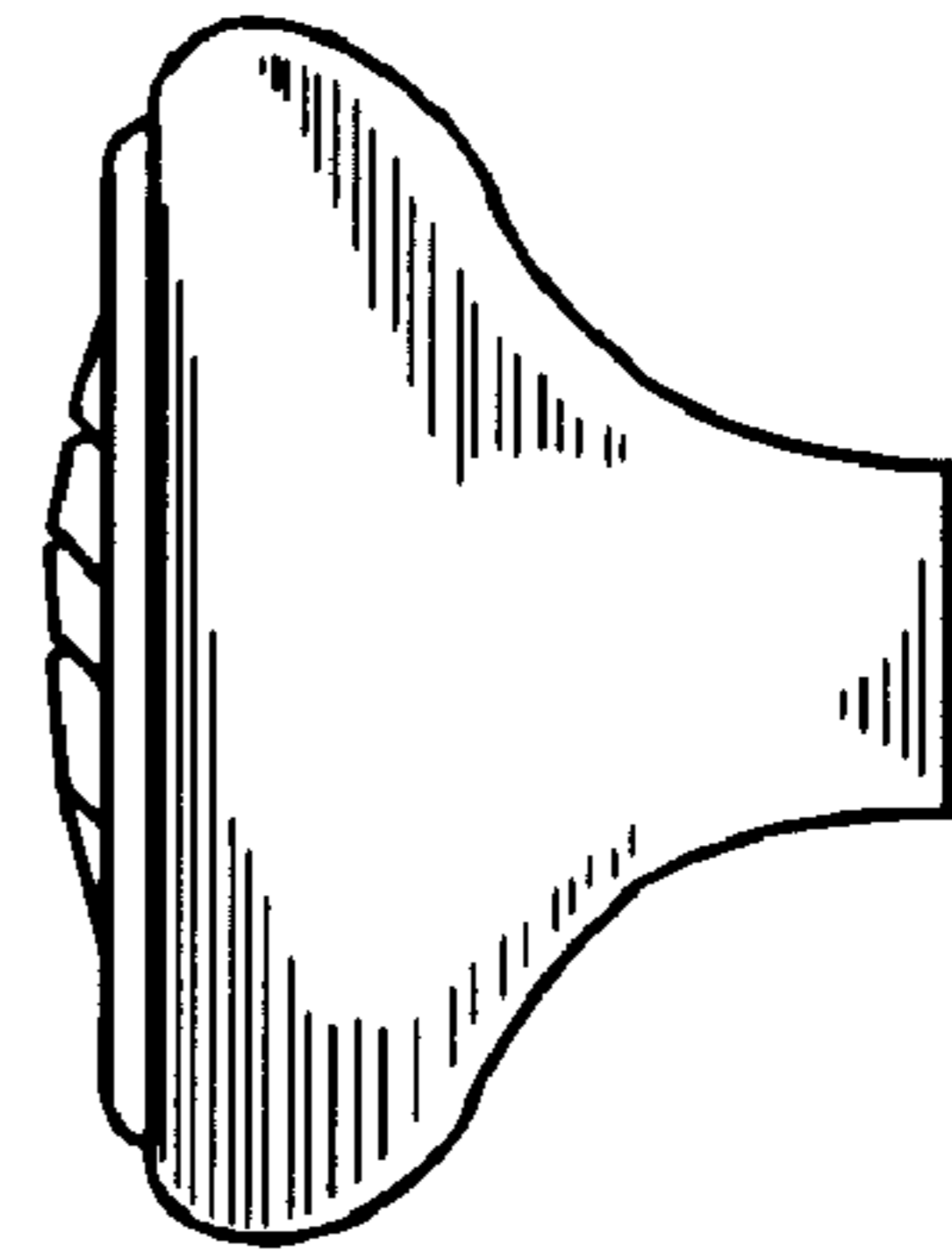
FIG. 1 is a front elevational view of a pull of the present invention;  
FIG. 2 is a right side elevational view thereof;  
FIG. 3 is a top view thereof;  
FIG. 4 is a cross-sectional view taken on line 4—4 of FIG. 1;  
FIG. 5 is a front elevational view of a second embodiment of the pull of the present invention;  
FIG. 6 is a right side elevational view thereof;  
FIG. 7 is a top view thereof; and,  
FIG. 8 is a cross-sectional view taken on line 8—8 of FIG. 5.

**1 Claim, 2 Drawing Sheets**

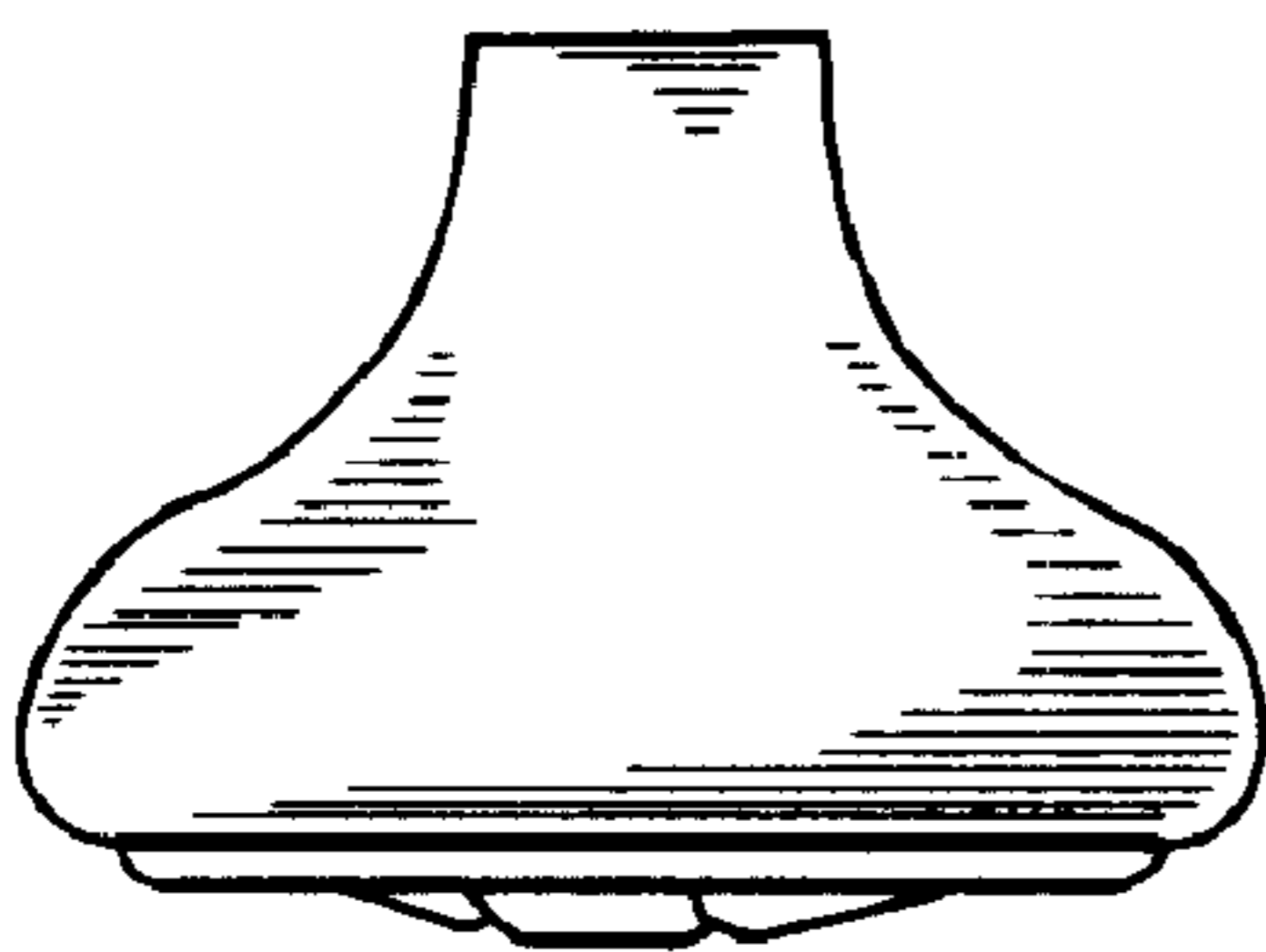




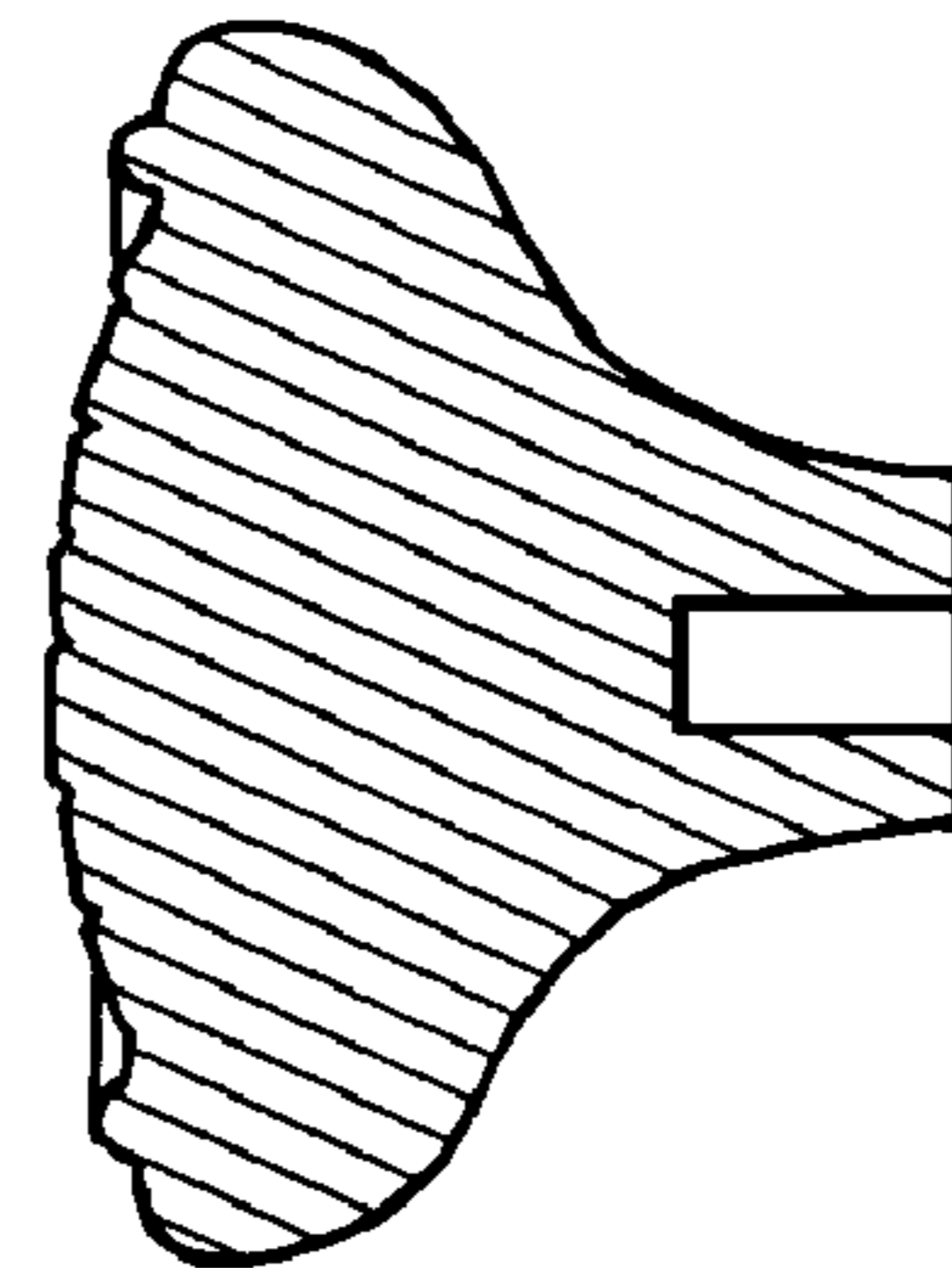
**Fig. 1**



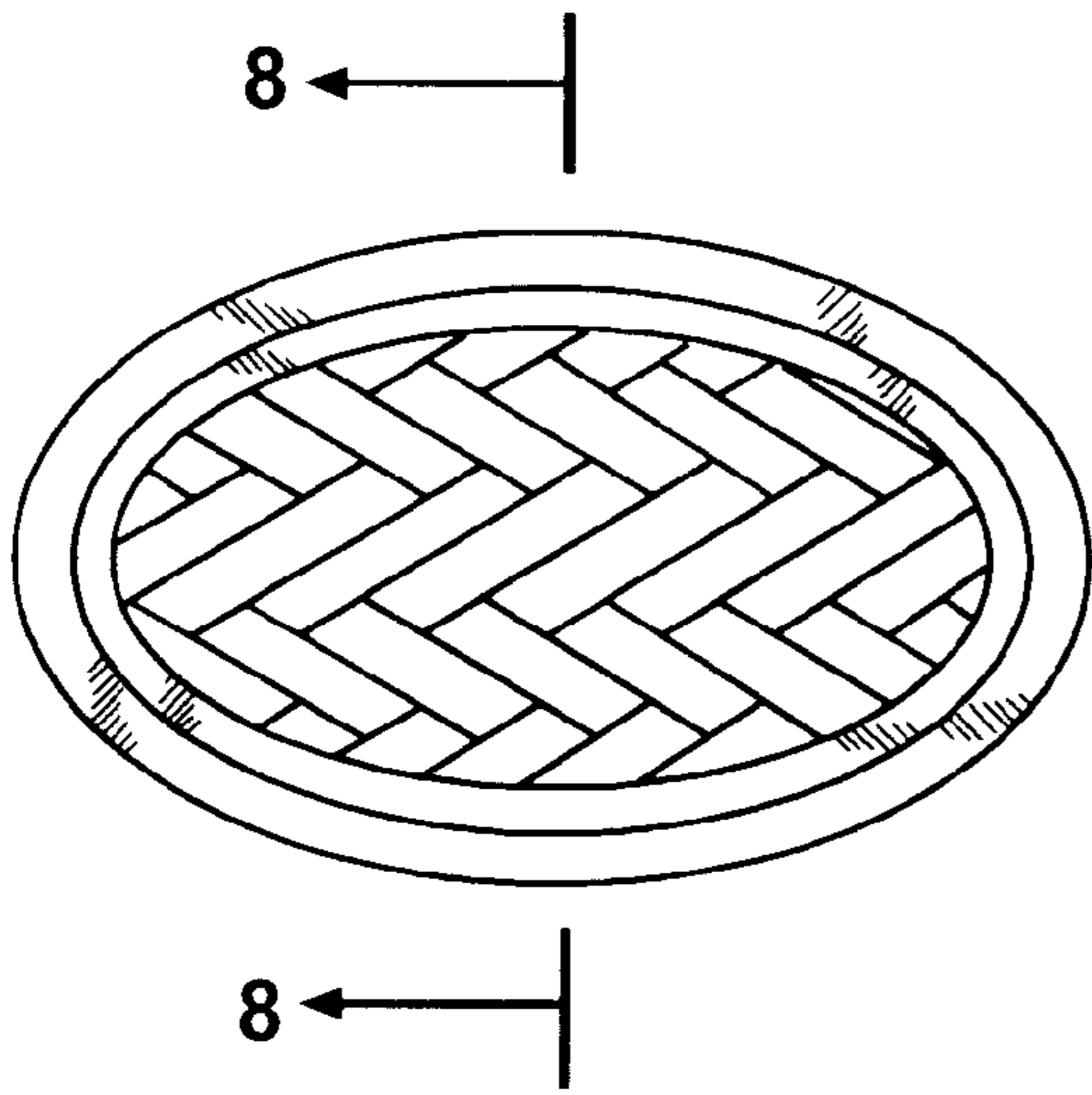
**Fig. 2**



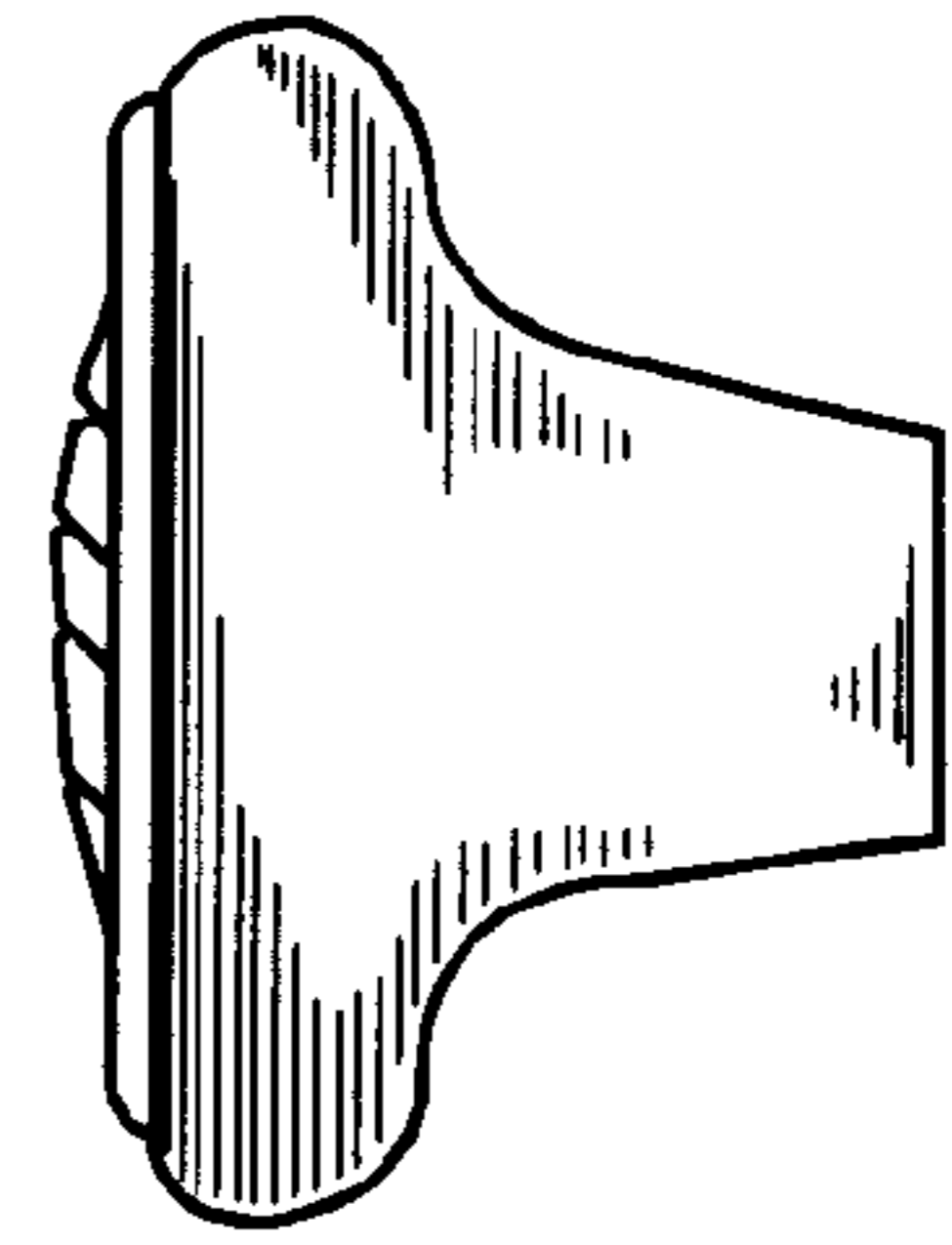
**Fig. 3**



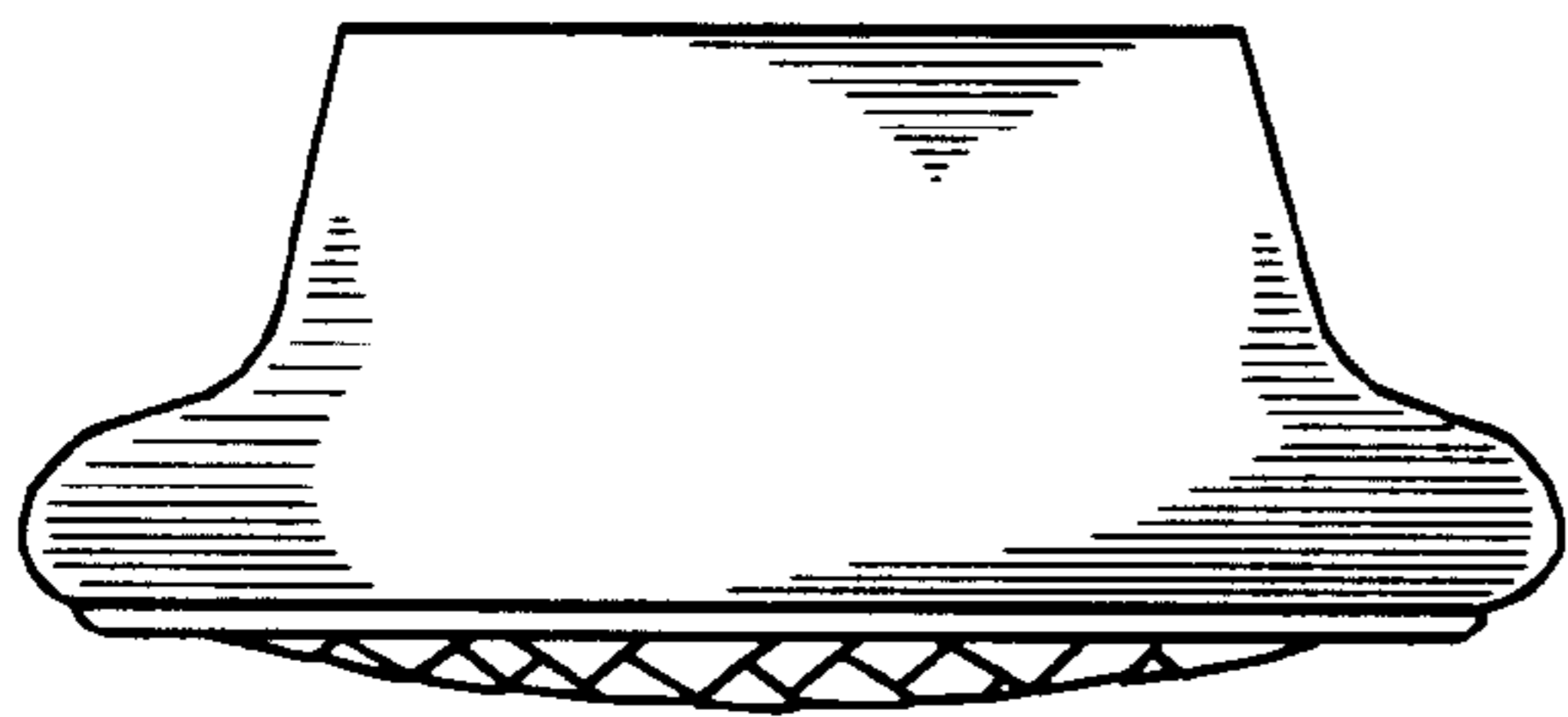
**Fig. 4**



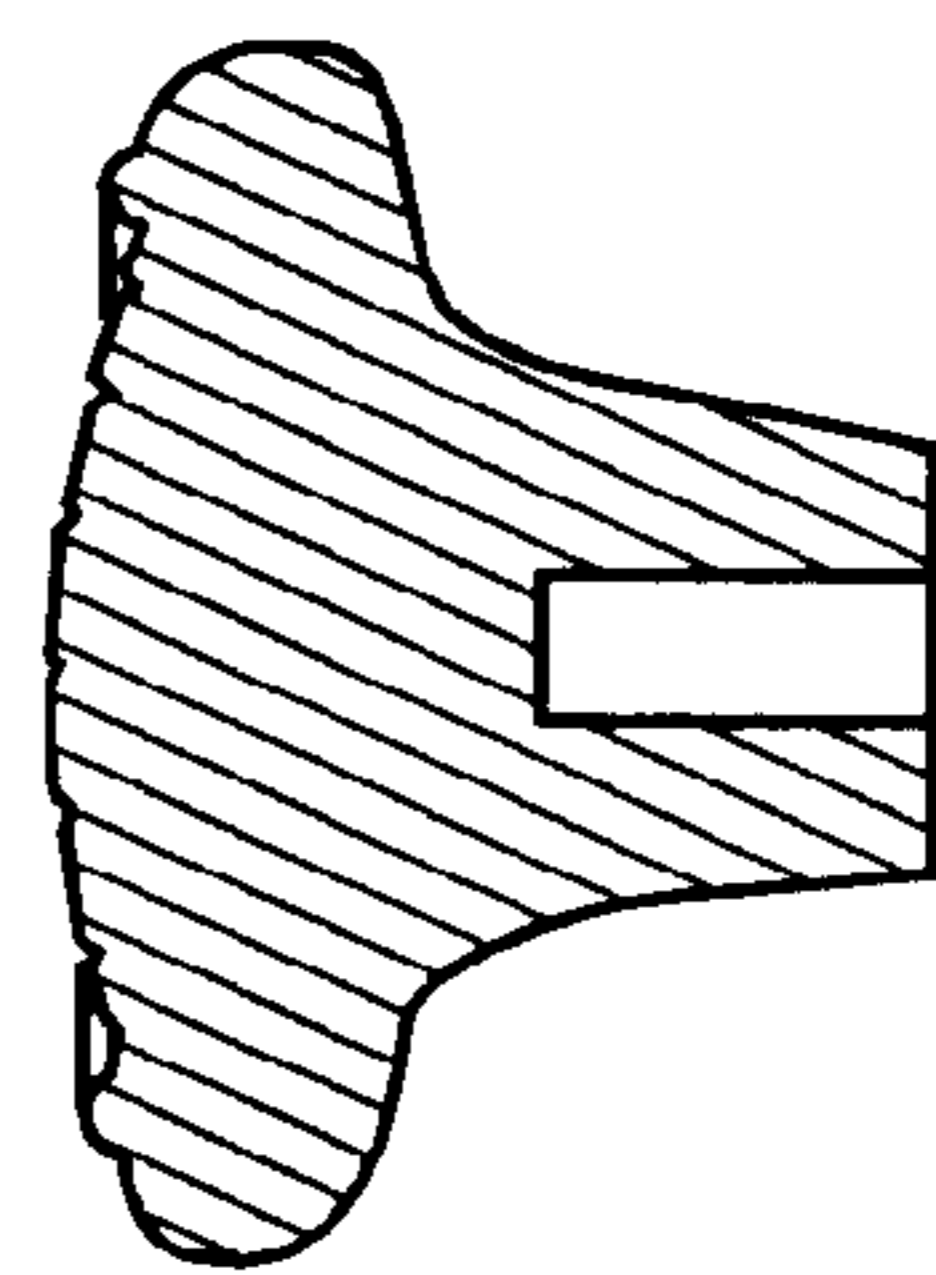
**Fig. 5**



**Fig. 6**



**Fig. 7**



**Fig. 8**