



US00D441709S

(12) **United States Design Patent**
Vian

(10) **Patent No.:** **US D441,709 S**

(45) **Date of Patent:** **** May 8, 2001**

(54) **VEHICLE WHEEL**

(75) Inventor: **Paolo Vian**, Verona (IT)

(73) Assignee: **Breed Automotive Technology, Inc.**,
Lakeland, FL (US)

(**) Term: **14 Years**

(21) Appl. No.: **29/115,425**

(22) Filed: **Dec. 14, 1999**

(30) **Foreign Application Priority Data**

Jun. 22, 1999 (IT) MI9900373

(51) **LOC (7) Cl.** **12-16**

(52) **U.S. Cl.** **D12/211**

(58) **Field of Search** D12/204-211;
301/37.1, 64.1, 65

(56) **References Cited**

U.S. PATENT DOCUMENTS

- D. 204,256 * 4/1966 Rader D12/211
- D. 284,182 * 6/1986 Hedlund D12/211
- D. 361,976 * 9/1995 Echazabal et al. D12/211
- D. 383,429 * 9/1997 Muzzarelli et al. D12/211
- D. 392,237 * 3/1998 Kelley D12/209
- D. 398,573 * 9/1998 Cattaneo D12/211
- D. 398,896 * 9/1998 Suprihanto D12/209
- D. 403,649 * 1/1999 Moreno D12/211

- D. 407,057 * 3/1999 Goplen D12/211
- D. 416,845 * 11/1999 Frueh D12/209
- D. 418,798 * 1/2000 Muzzarelli et al. D12/211
- D. 423,446 * 4/2000 Chung D12/211
- D. 425,472 * 5/2000 Donikoglu D12/209
- D. 433,371 * 11/2000 Donikoglu D12/209

* cited by examiner

Primary Examiner—Stacia Cadmus

(74) *Attorney, Agent, or Firm*—Lonnie Drayer

(57) **CLAIM**

The ornamental design for a vehicle wheel, as shown and described.

DESCRIPTION

FIG. 1 is a front view of a vehicle wheel, showing my new design;
 FIG. 2 is a side elevation view thereof;
 FIG. 3 is a rear view thereof; and,
 FIG. 4 is a cross sectional view taken along line 4—4 of FIG. 3;
 FIG. 5 is a front view of a second embodiment of a vehicle wheel showing my new design;
 FIG. 6 is a side elevation view thereof;
 FIG. 7 is a rear view thereof; and,
 FIG. 8 is a cross sectional view taken along line 8—8 of FIG. 7.

1 Claim, 4 Drawing Sheets

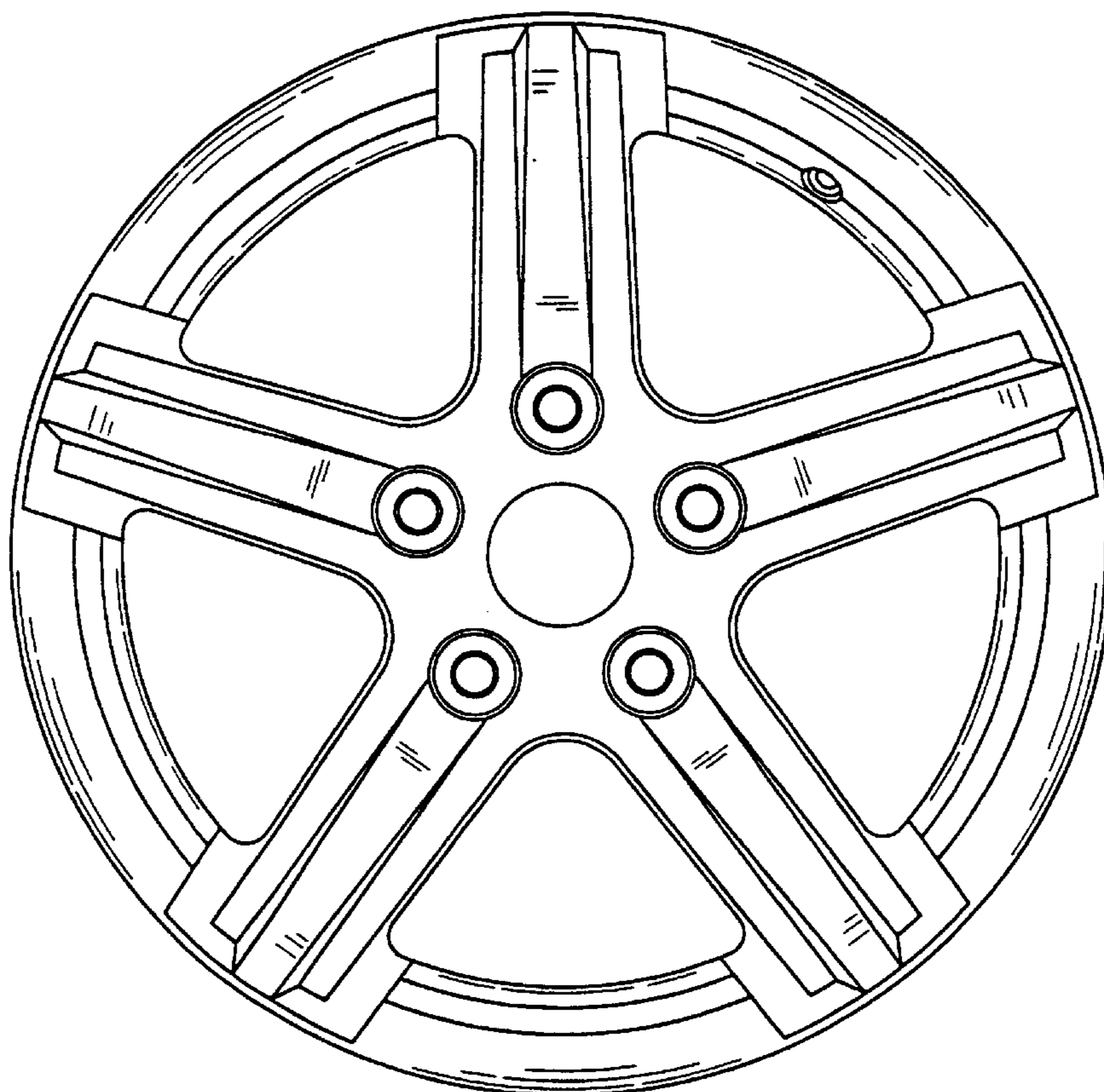

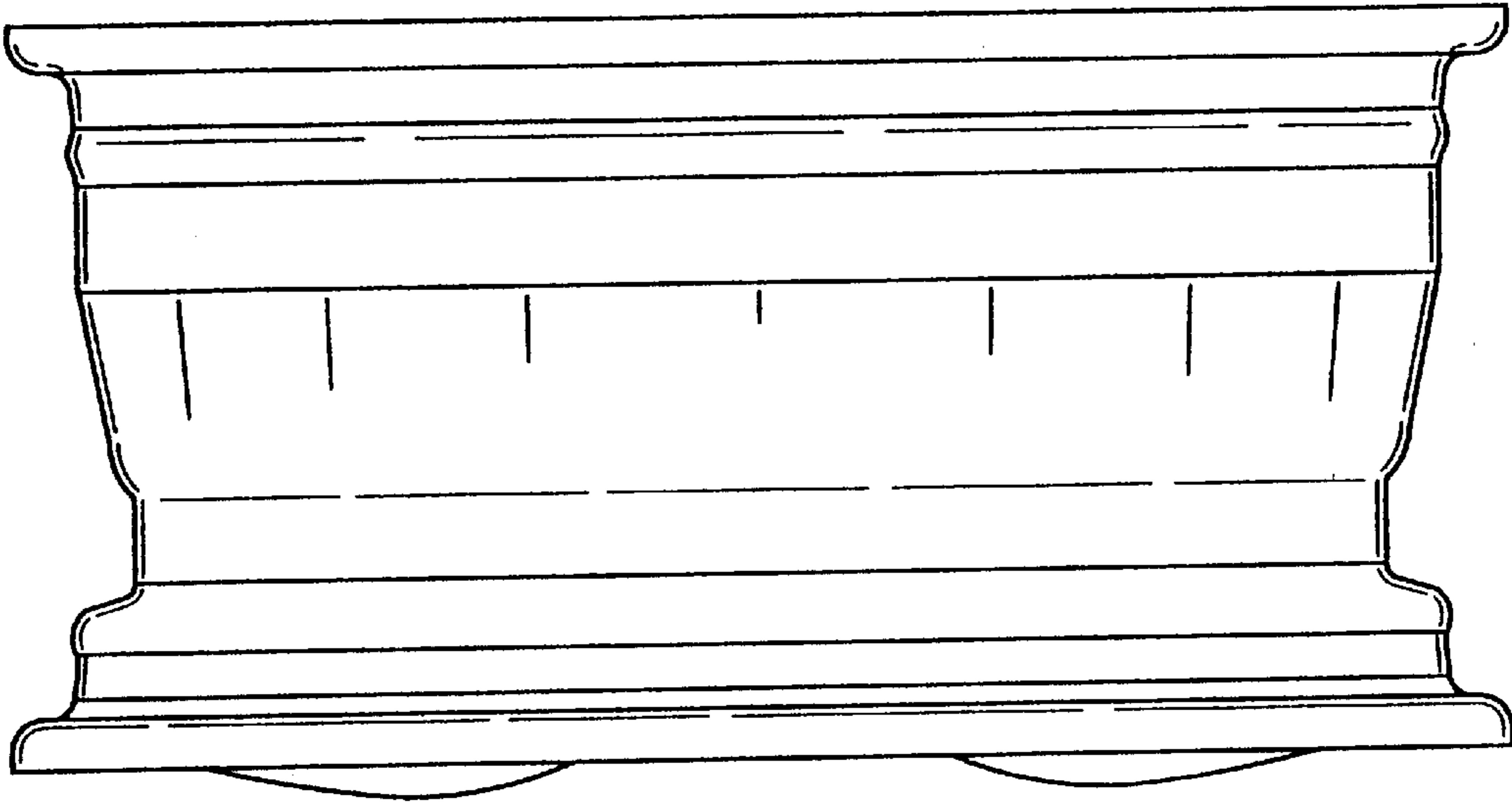

FIG-2

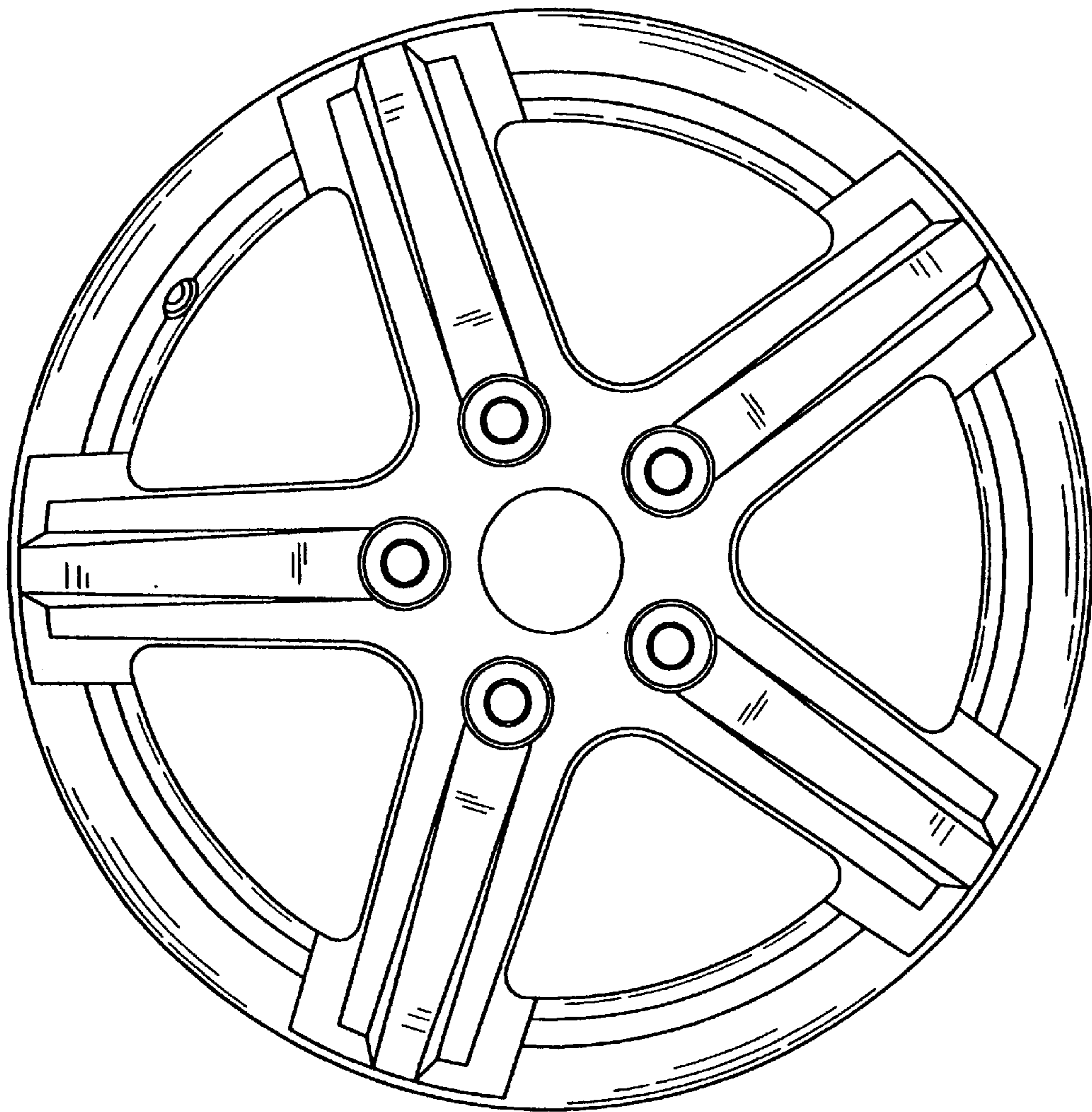

FIG-1

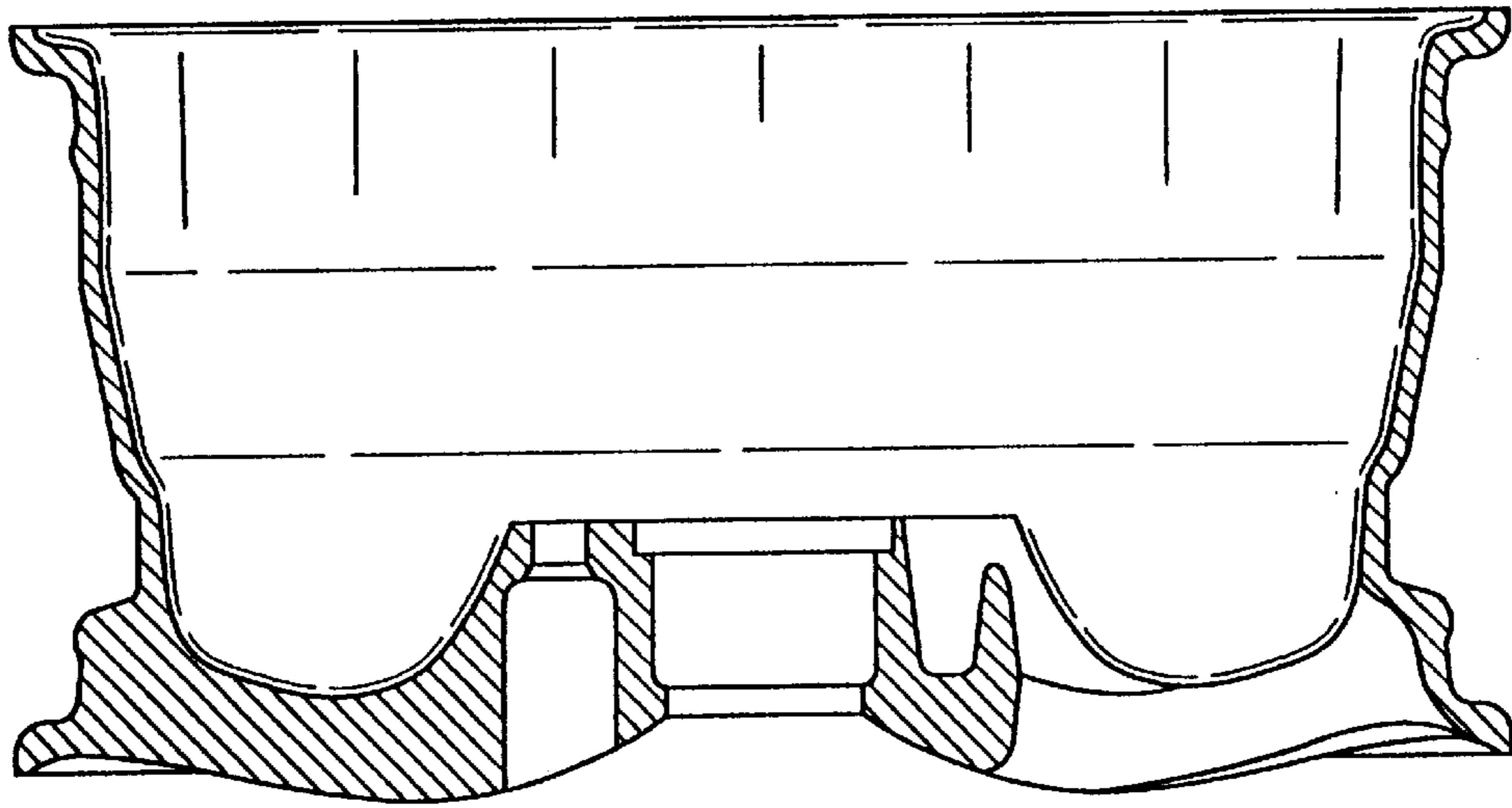

FIG-4

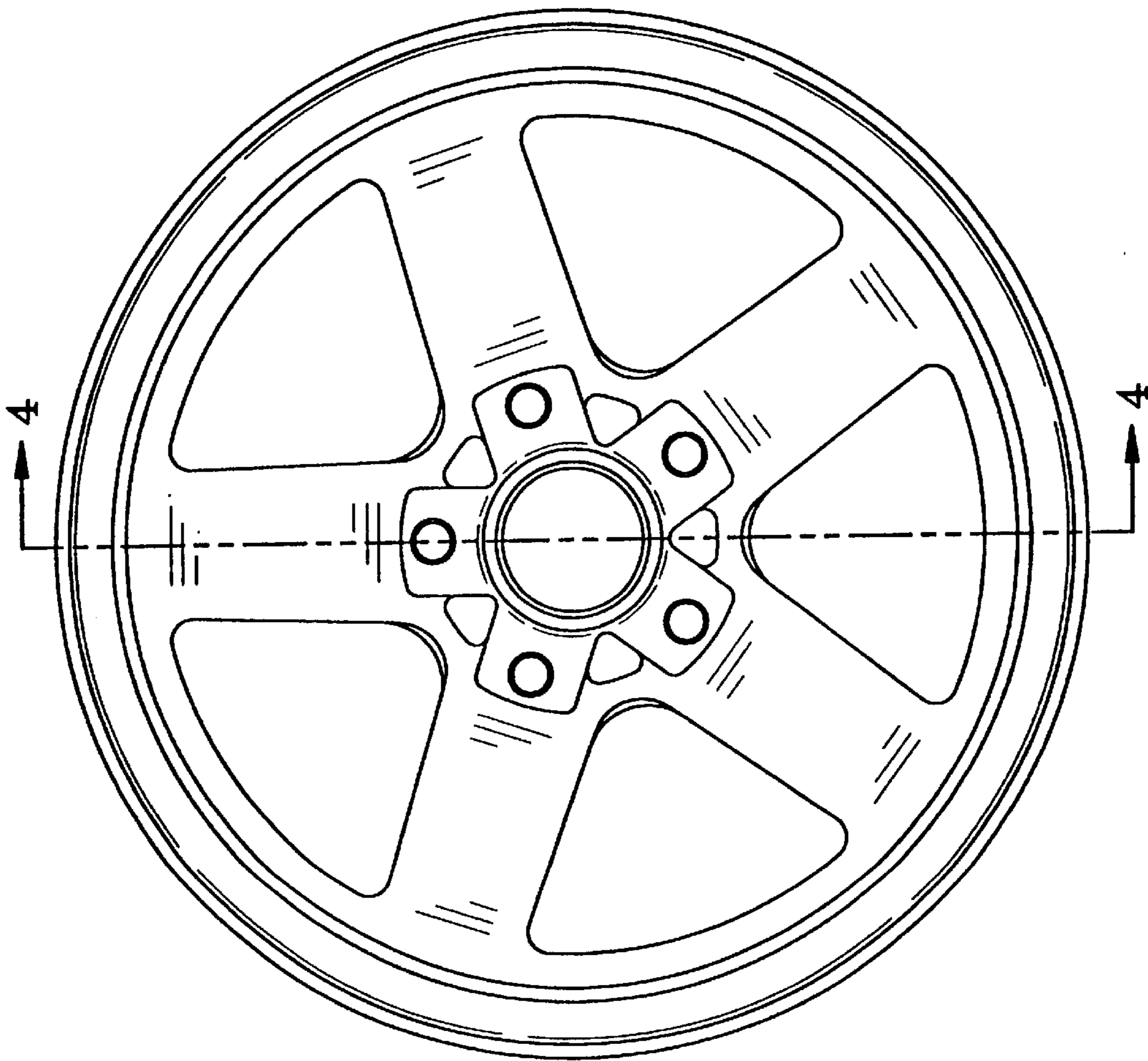

FIG-3

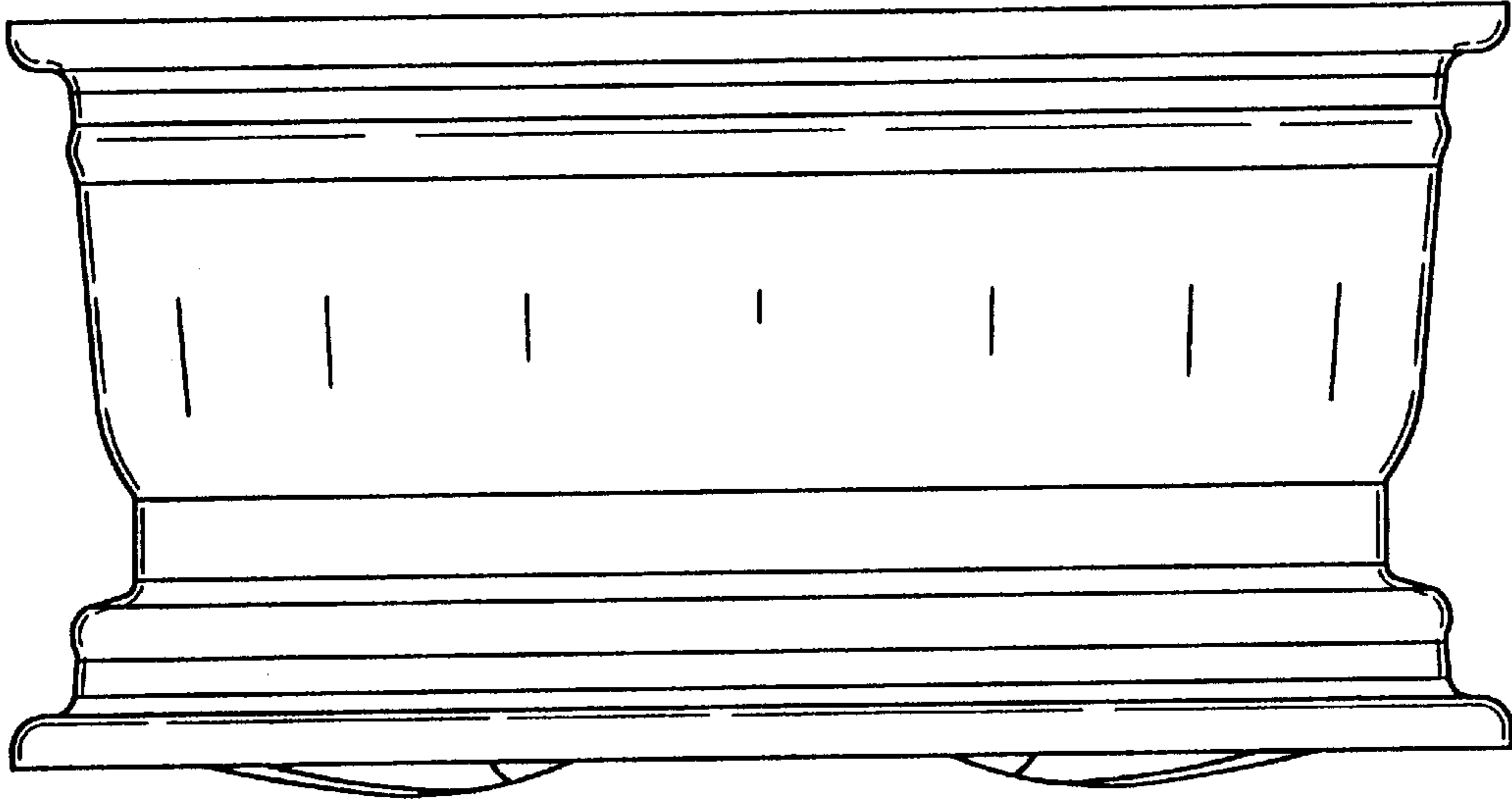

FIG-6

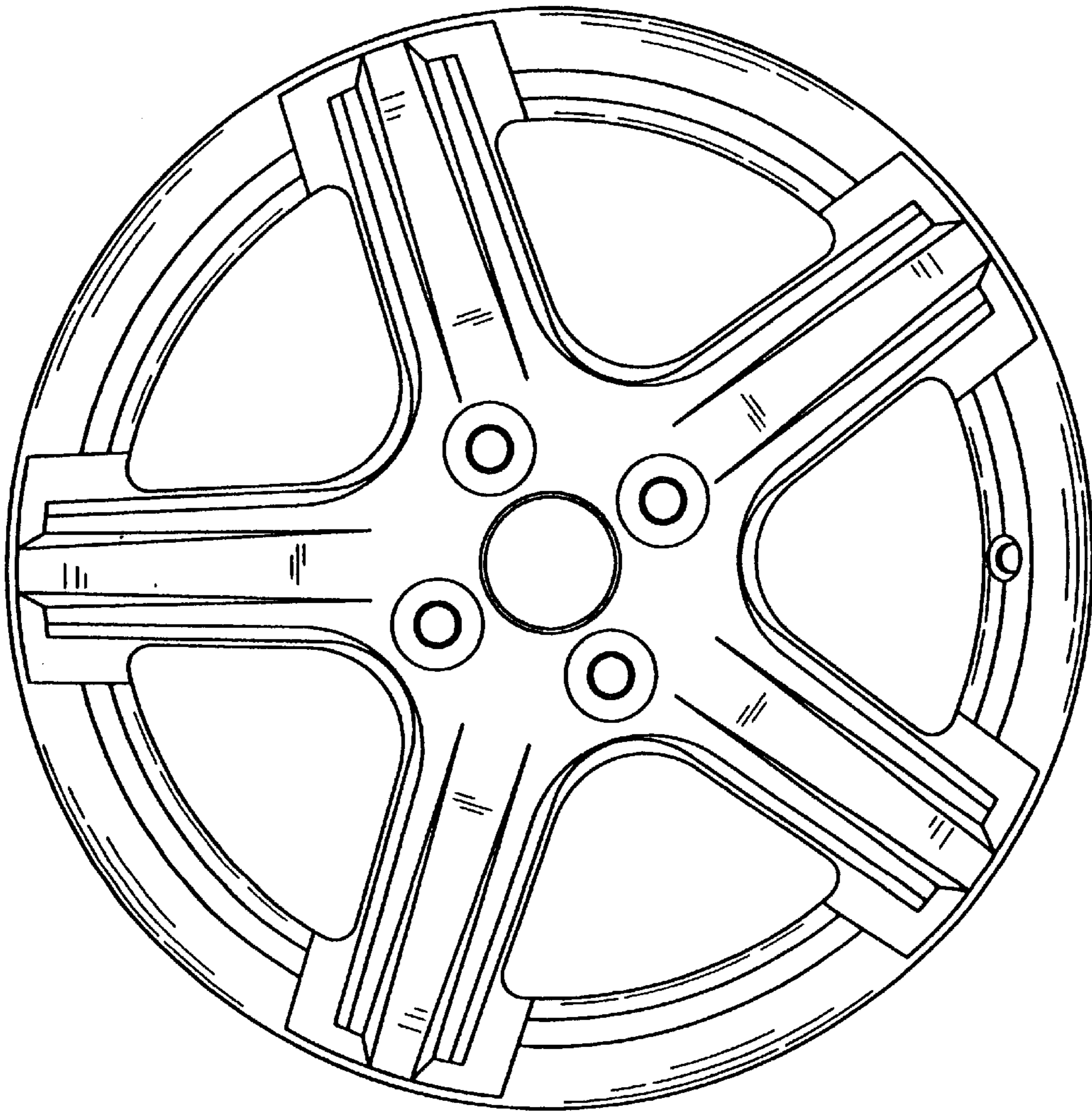

FIG-5

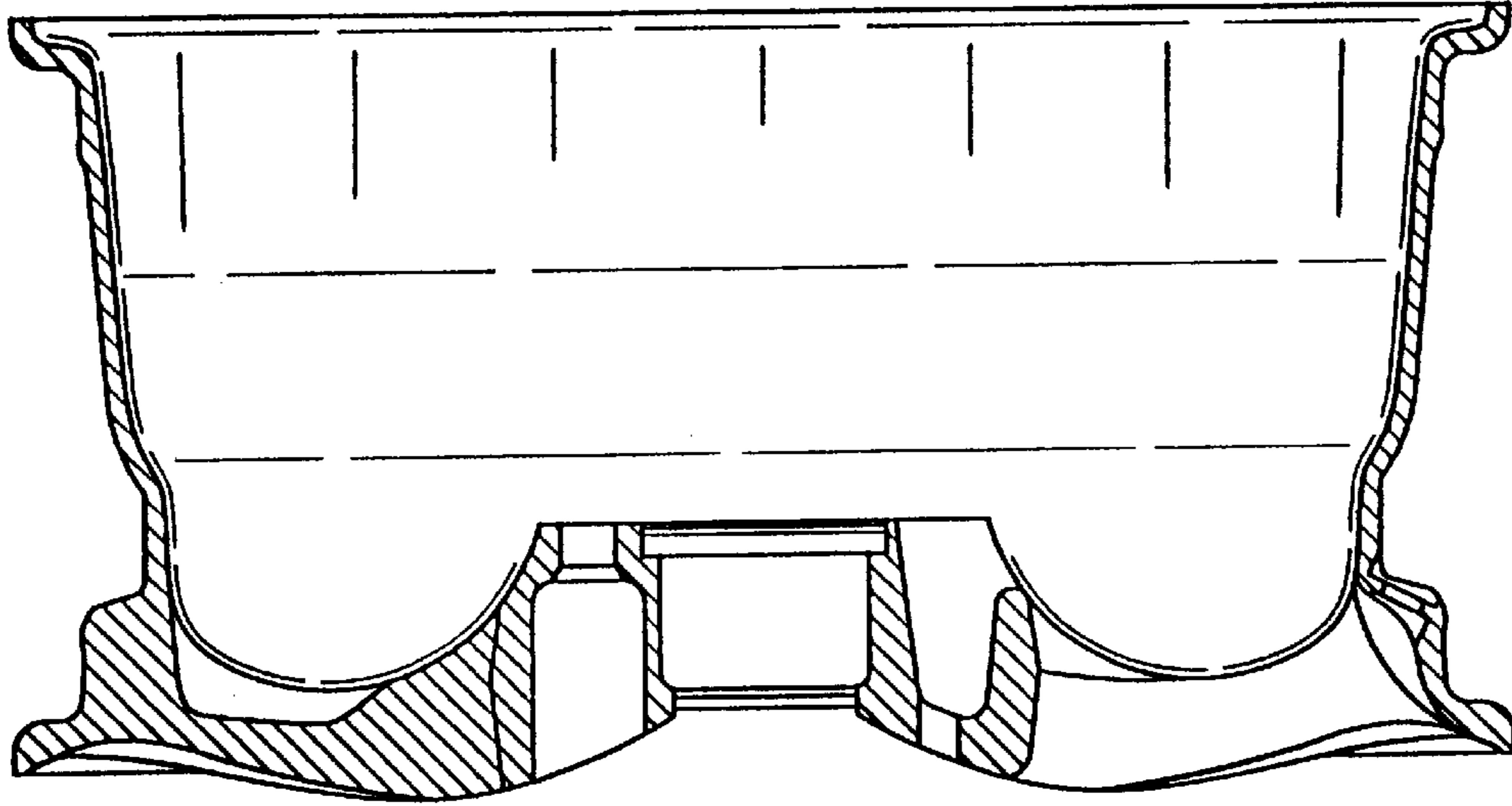

FIG-8

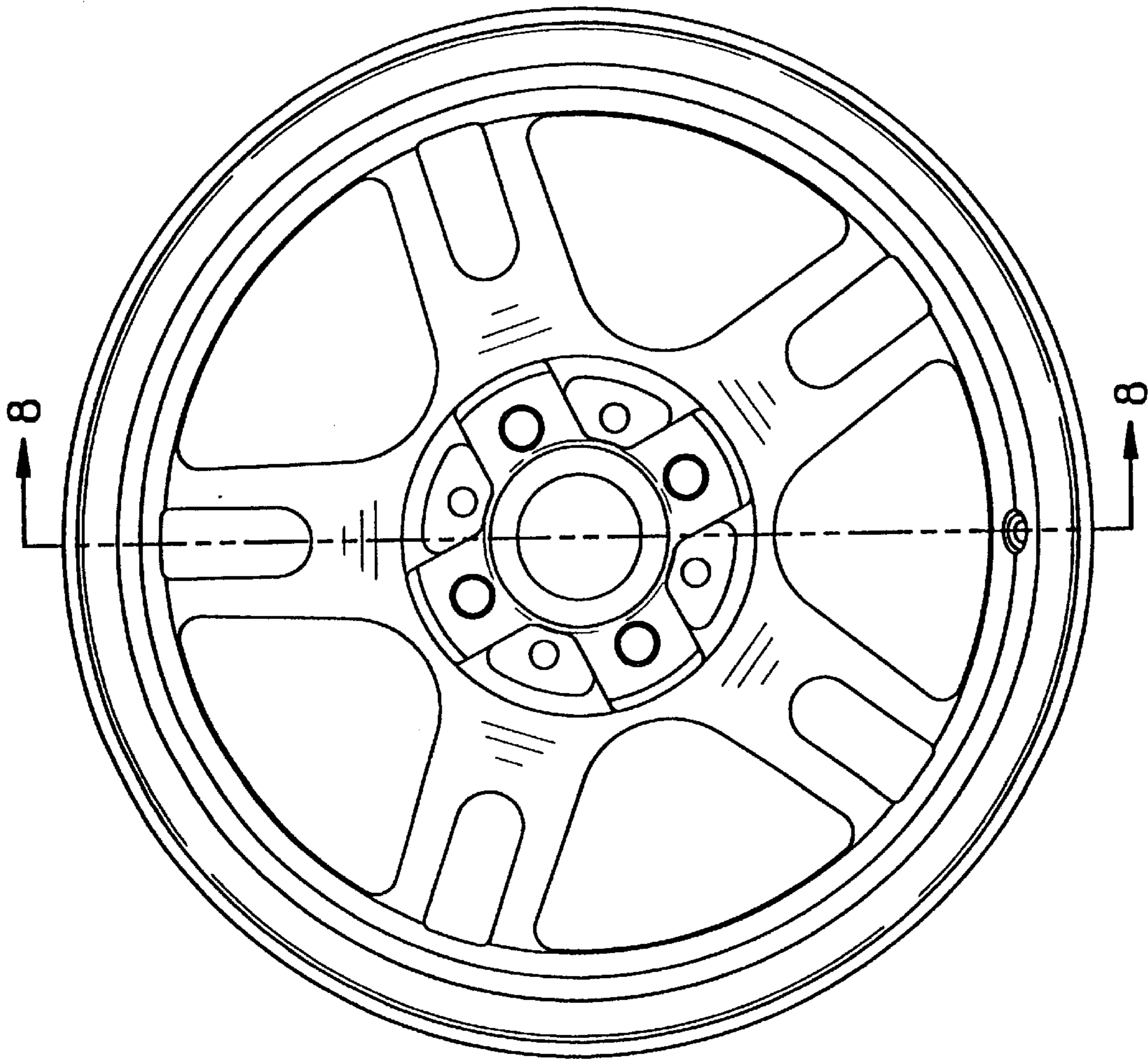

FIG-7