



US00D441409S

(12) **United States Design Patent**
Tagg

(10) **Patent No.:** **US D441,409 S**

(45) **Date of Patent:** **** May 1, 2001**

(54) **SET OF ROAD BARRIER AND EXECUTIVE TOY PIECES**

(76) **Inventor:** **Richard Tagg**, Risinghall House,
Snadhutton, York YO4 1JZ (GB)

(**) **Term:** **14 Years**

(21) **Appl. No.:** **29/125,831**

(22) **Filed:** **Jun. 30, 2000**

(30) **Foreign Application Priority Data**

Mar. 25, 2000 (GB) 2090745

(51) **LOC (7) Cl.** **21-01**

(52) **U.S. Cl.** **D21/483; D21/484; D10/113;**
D11/157

(58) **Field of Search** D21/483, 484,
D21/486, 494, 493, 502-505; D11/157;
D10/109, 113; 116/63 P, 63 C; 446/476,
85, 102, 104, 110, 111, 122, 124

(56) **References Cited**

U.S. PATENT DOCUMENTS

D. 208,789	*	10/1967	Kuhn	D21/505
D. 315,752	*	3/1991	Wentling	D21/493
D. 350,168	*	8/1994	Ruszkai	D21/483
D. 361,952	*	9/1995	Stockman	D10/109
D. 391,513	*	3/1998	Brown	D10/113
D. 410,705	*	6/1999	Toft	D21/486
D. 414,826	*	10/1999	Rudy	D21/504
D. 421,235	*	2/2000	Rausch	D10/113
D. 426,588	*	6/2000	Glickman	D21/486
3,034,254	*	5/1962	Christiansen	D21/505
5,460,115	*	10/1995	Speer et al.	116/63 P

OTHER PUBLICATIONS

Toys and Novelties, P47, Aug. 1962.*

* cited by examiner

Primary Examiner—Raphael Barkai

(74) *Attorney, Agent, or Firm*—Edwin D. Schindler

(57) **CLAIM**

The ornamental design for a set of road barrier and executive toy pieces, as shown and described.

DESCRIPTION

FIG. 1 is a front perspective view of a female end segment of the set of road barrier and executive toy pieces showing my new design, the showing of part of the set in FIGS. 1-9 and 12 is for ease of illustration only;

FIG. 2 is a rear perspective view thereof;

FIG. 3 is a bottom perspective view thereof;

FIG. 4 is a front perspective view of a male end segment of the set of road barrier and executive toy pieces;

FIG. 5 is a bottom perspective view thereof;

FIG. 6 is a front perspective view of a segment of the set of road barrier and executive toy pieces;

FIG. 7 is a rear perspective view thereof;

FIG. 8 is a bottom perspective view thereof;

FIG. 9 is a bottom perspective view thereof;

FIG. 10 is an exploded view of the set of road barrier and executive toy pieces;

FIG. 11 is a partial perspective view of the set of road barrier and executive toy pieces, in an alternative position;

FIG. 12 is an enlarged perspective view of two segments of the set of road barrier and executive toy pieces; and,

FIG. 13 is an enlarged partial perspective view of the set of road barrier and executive toy pieces.

1 Claim, 13 Drawing Sheets

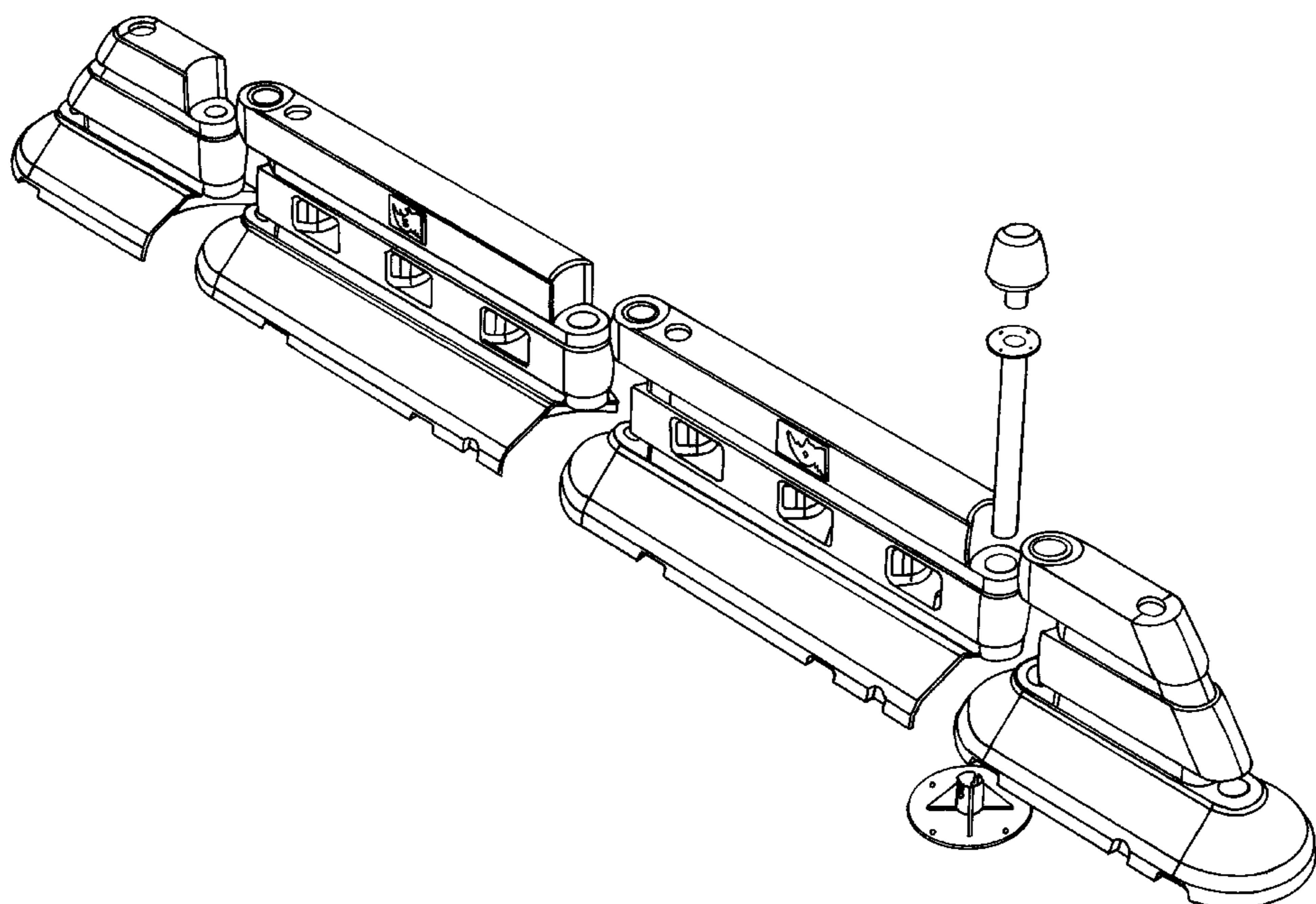

FIG. 1

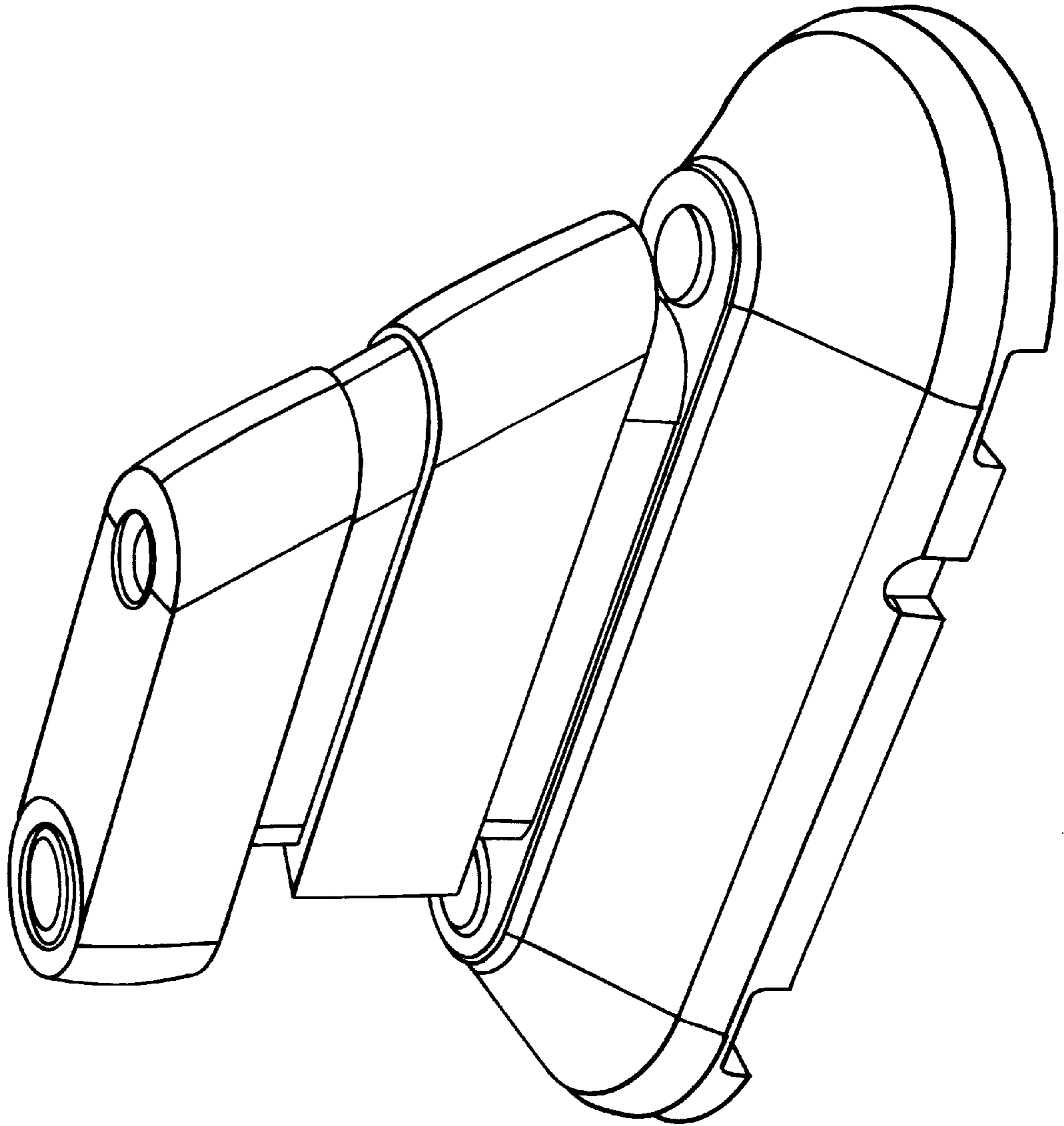

FIG. 2

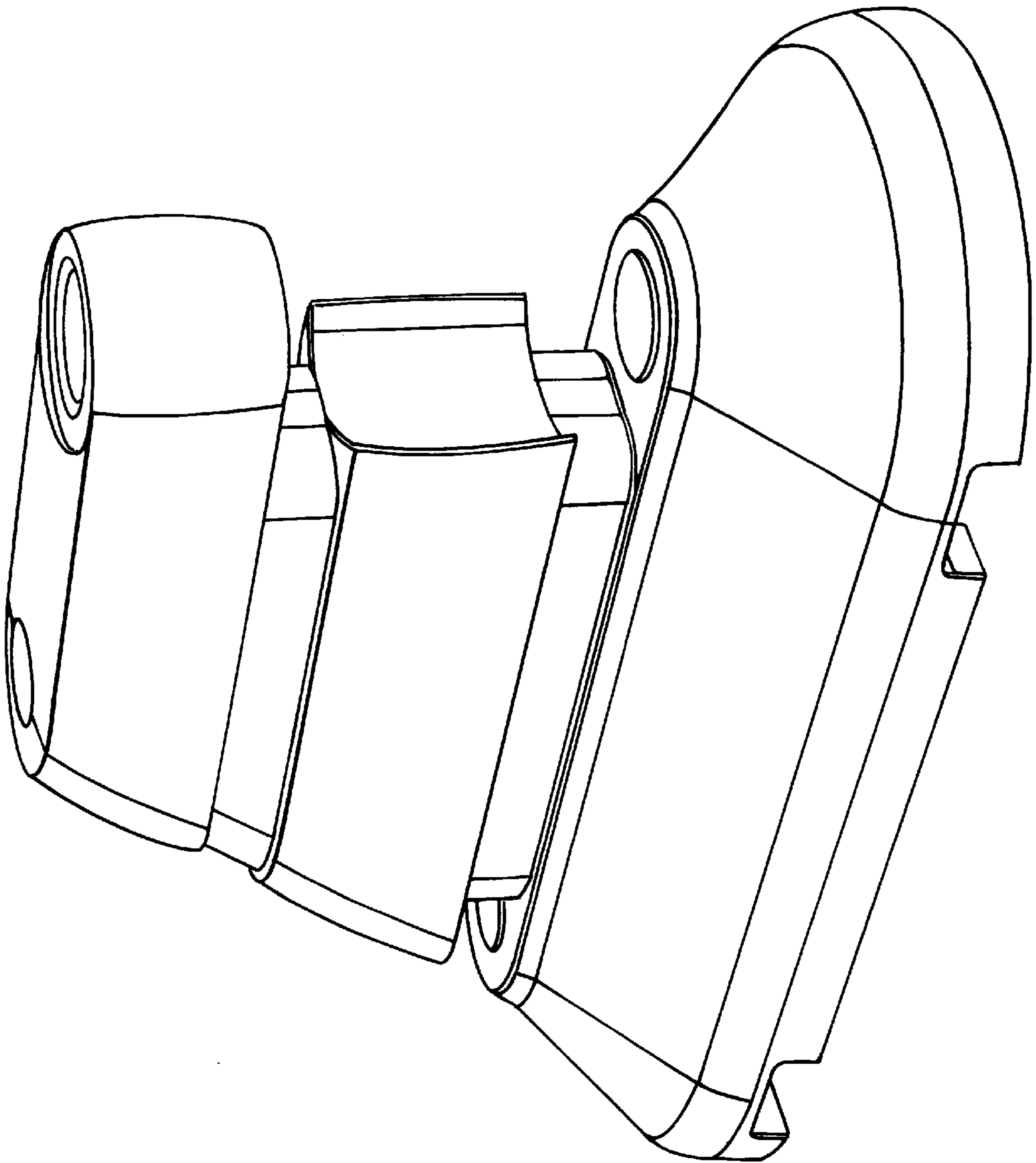

FIG. 3

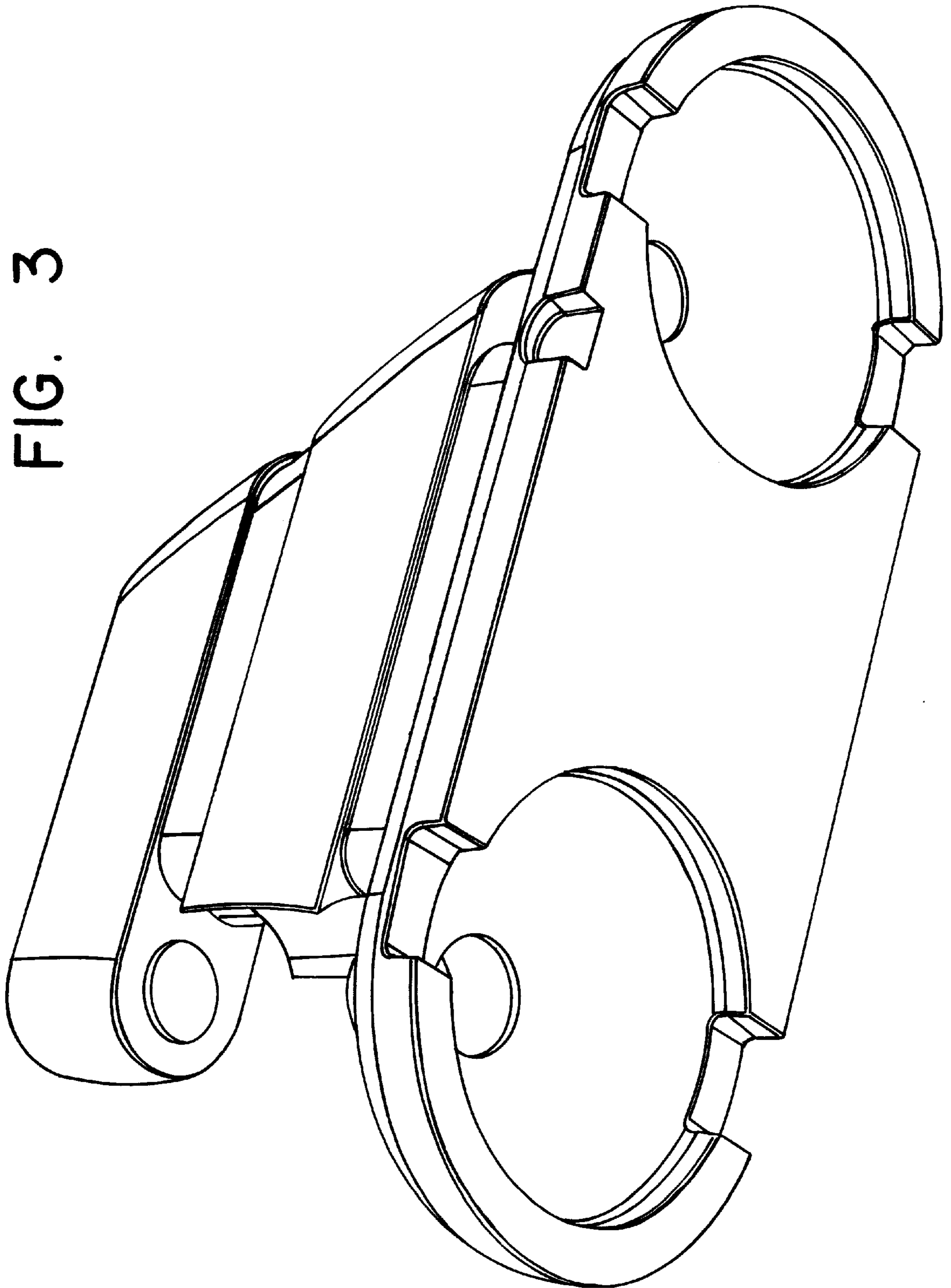

FIG. 4

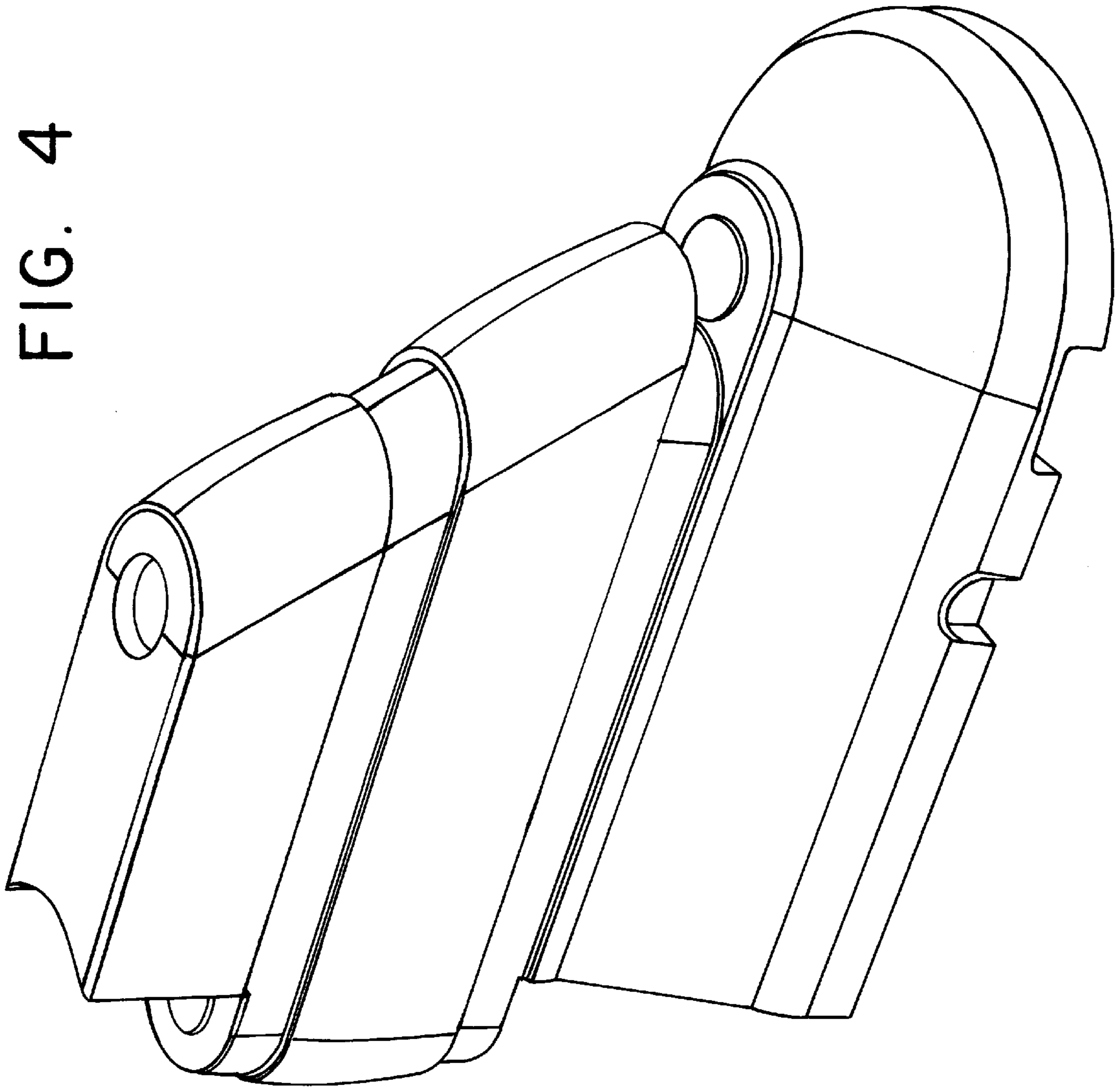

FIG. 5

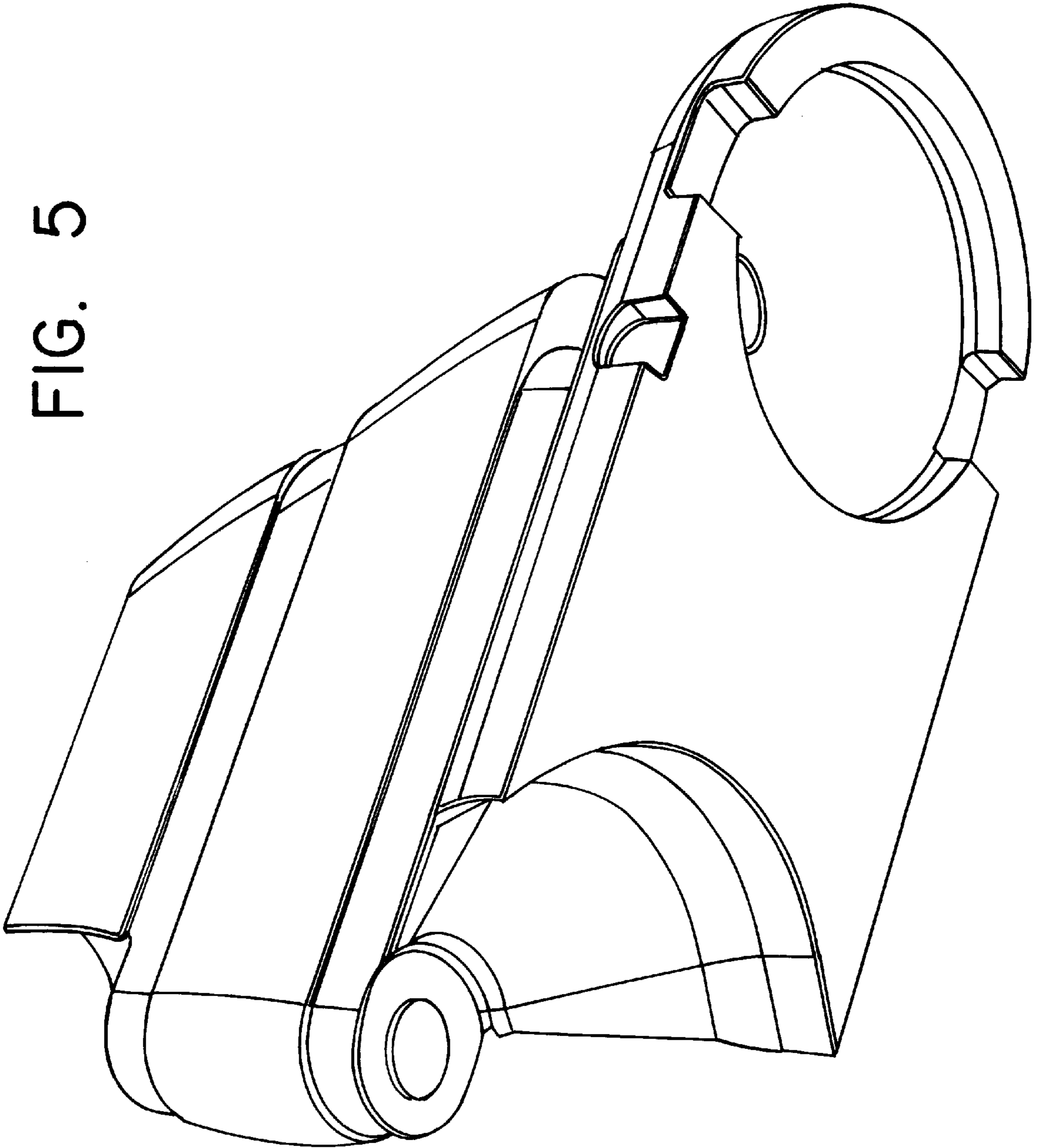

FIG. 6

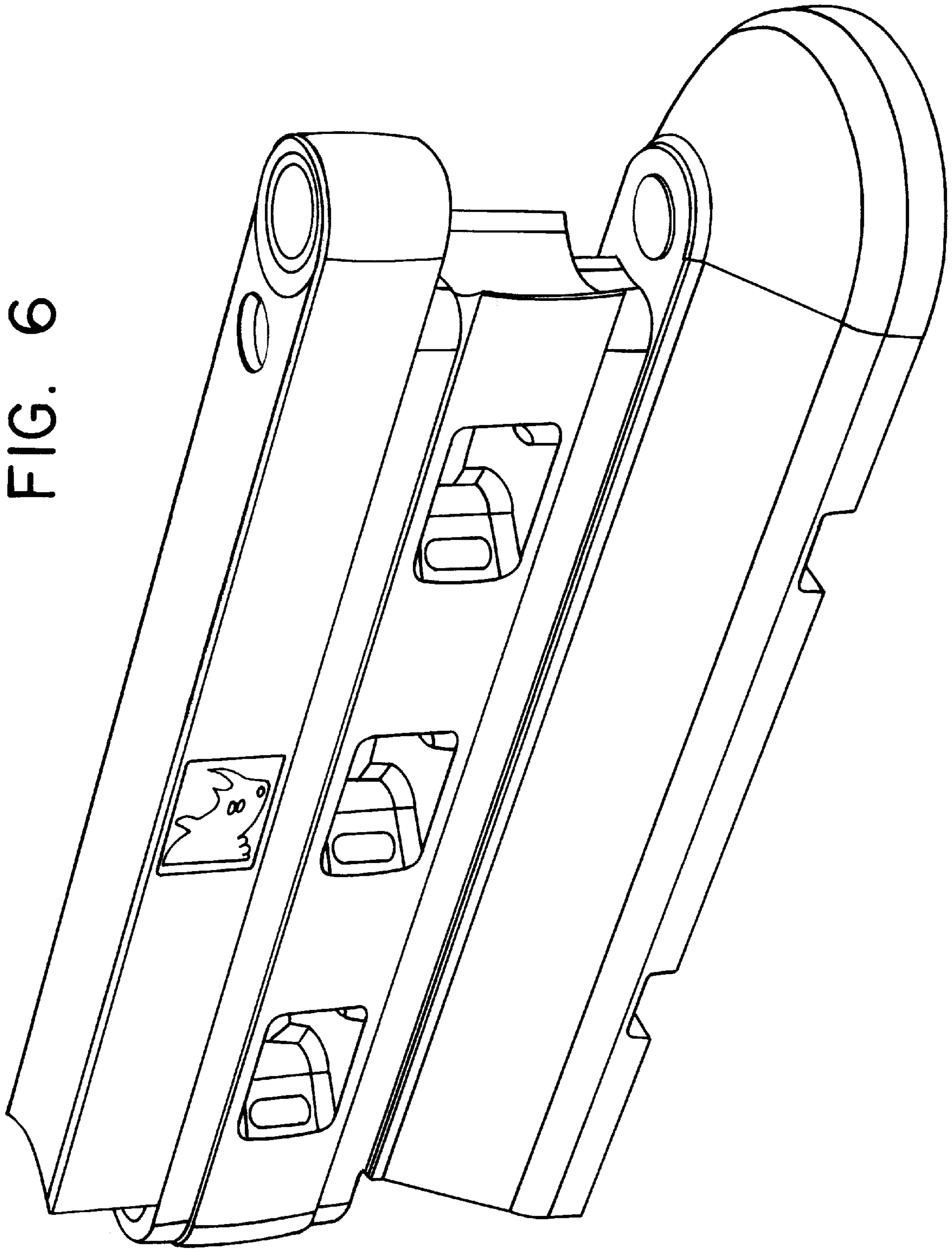

FIG. 7

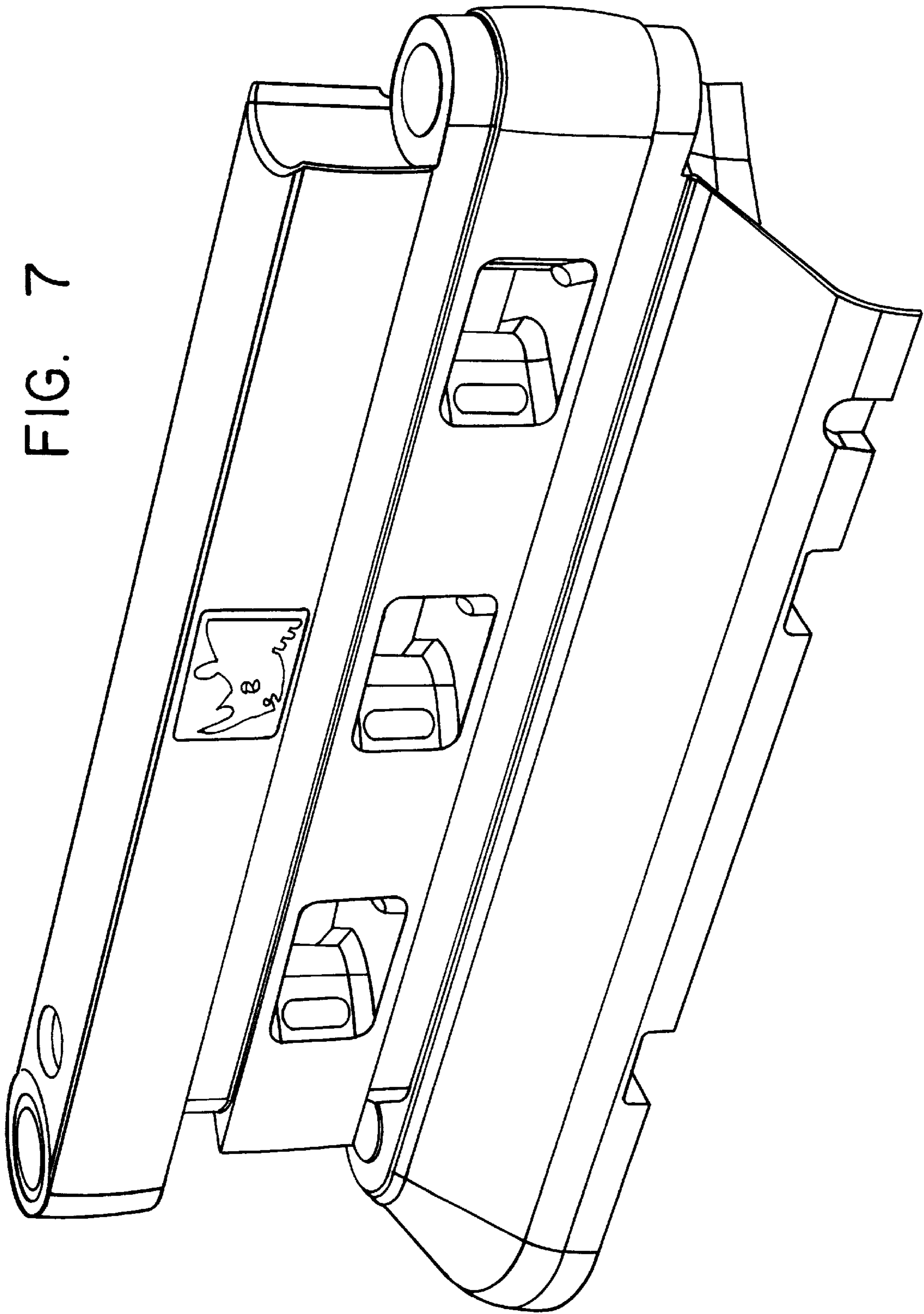

FIG. 8

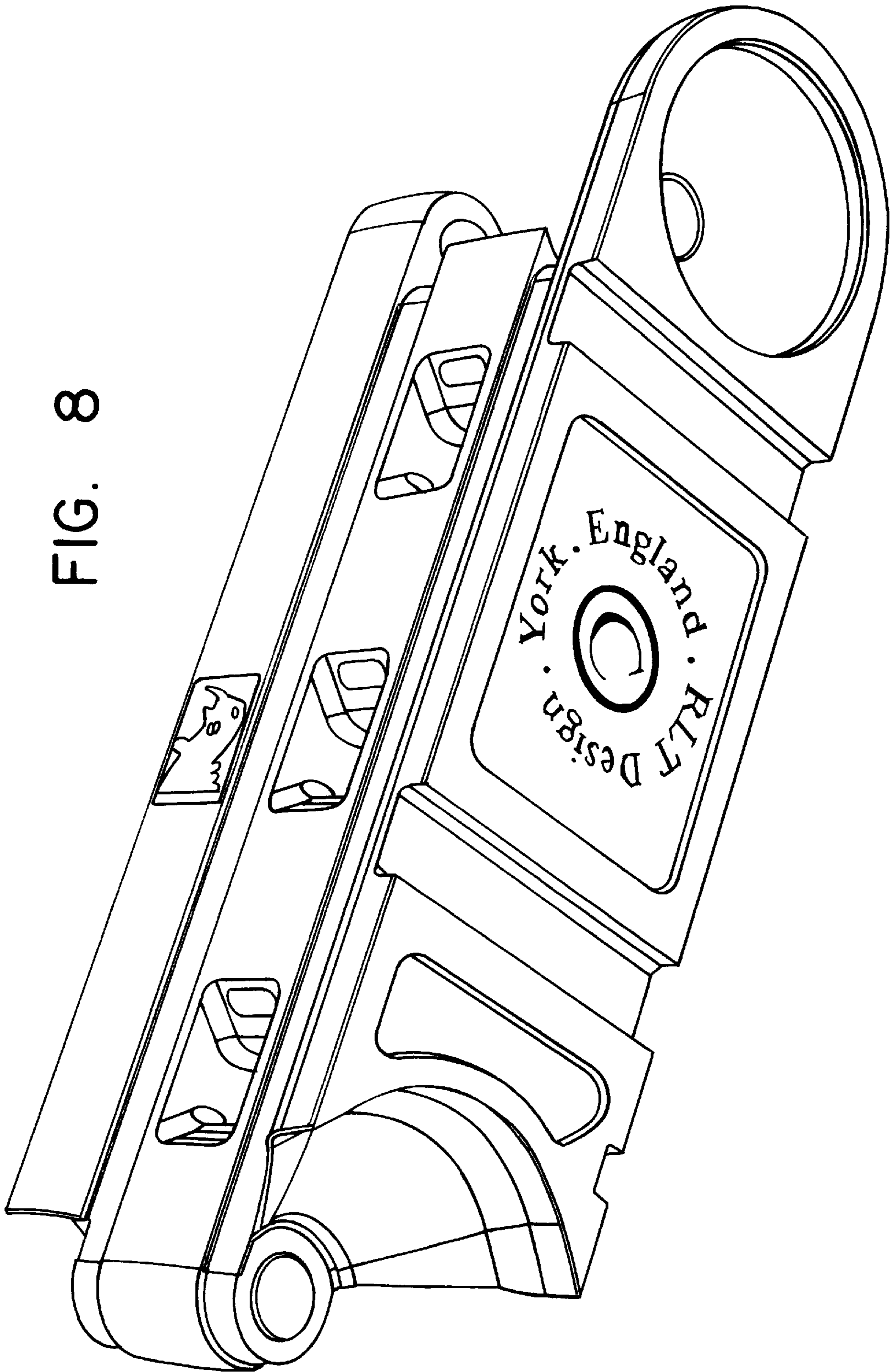

FIG. 9

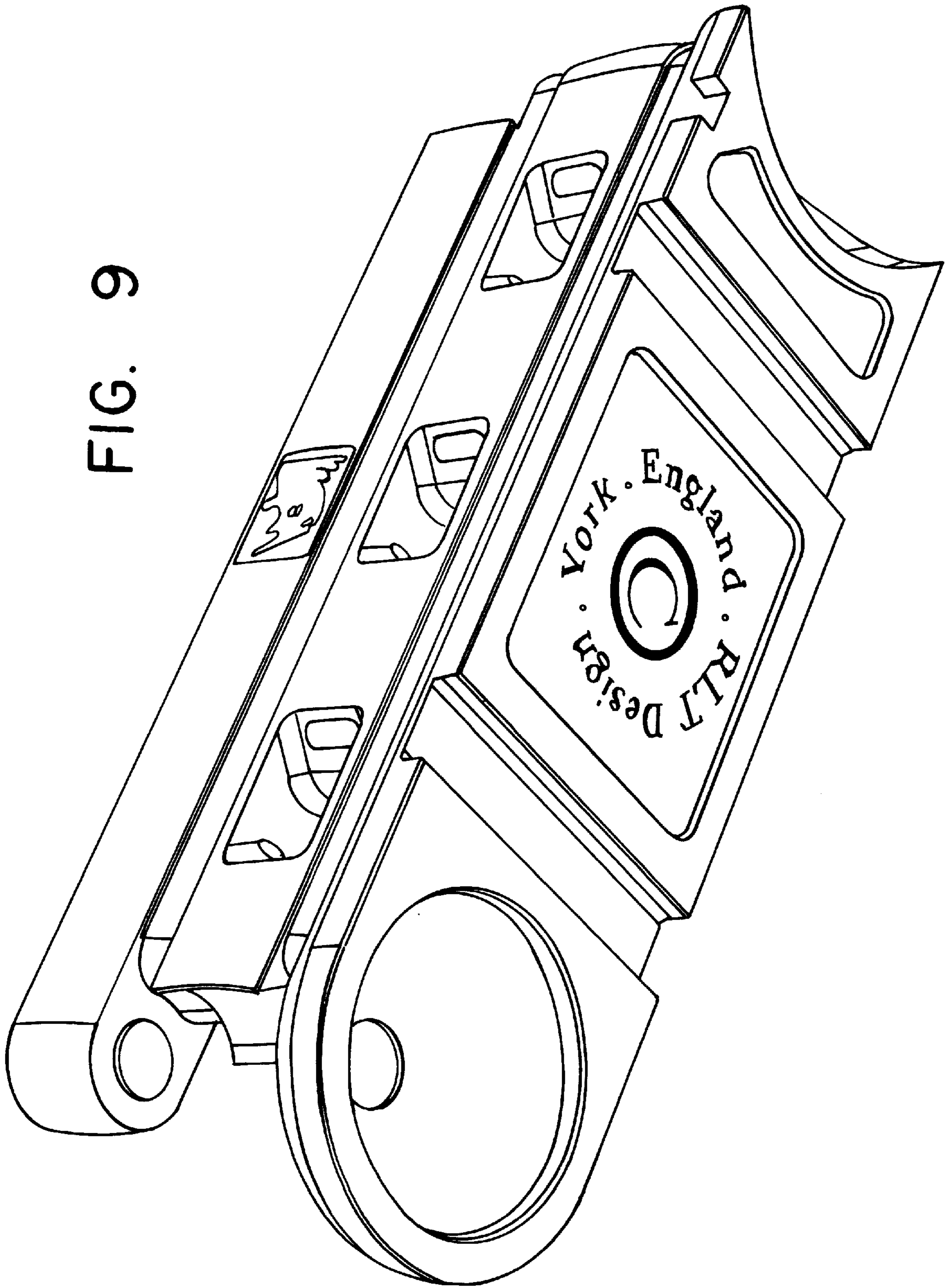

FIG. 10

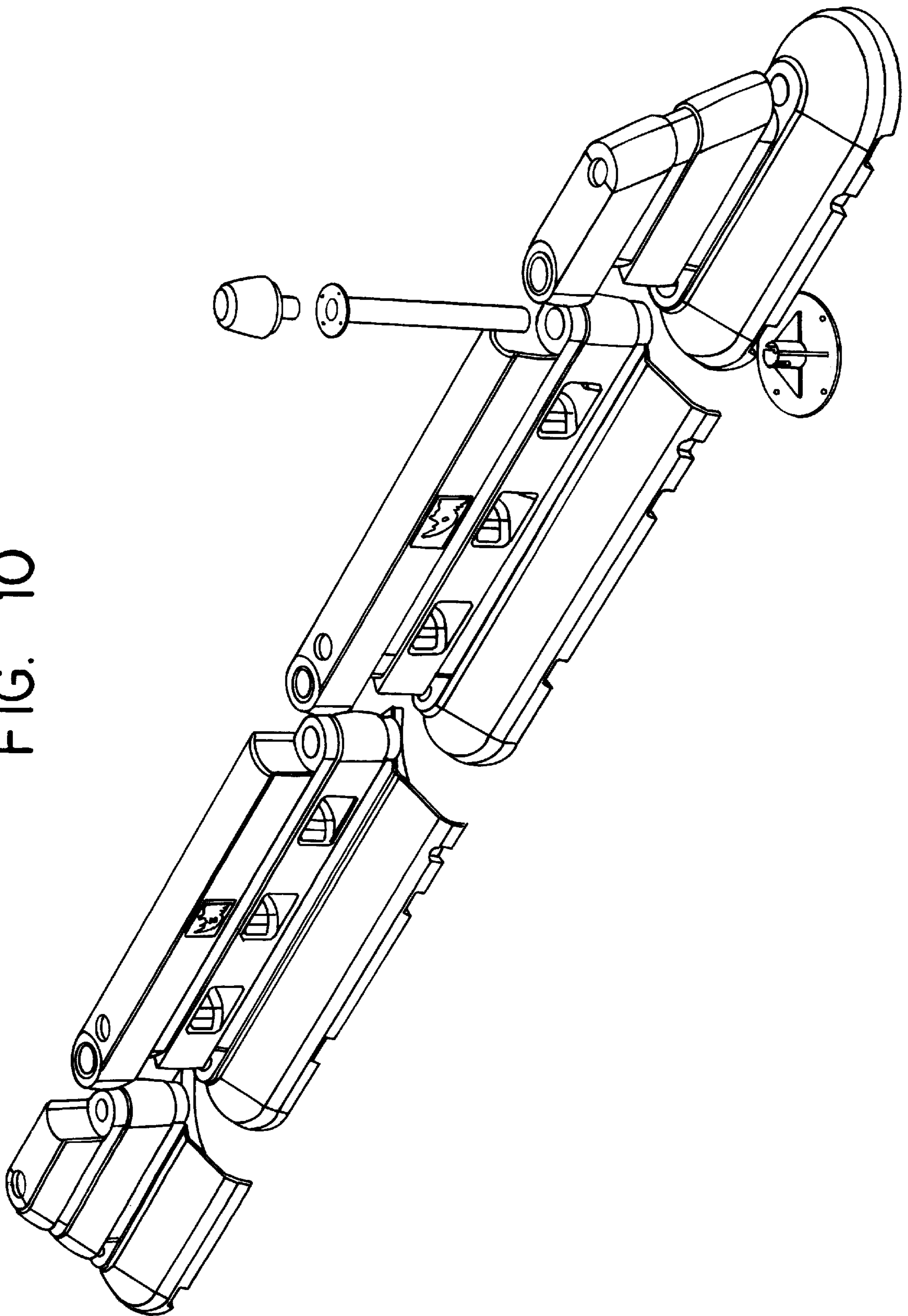

FIG. 11

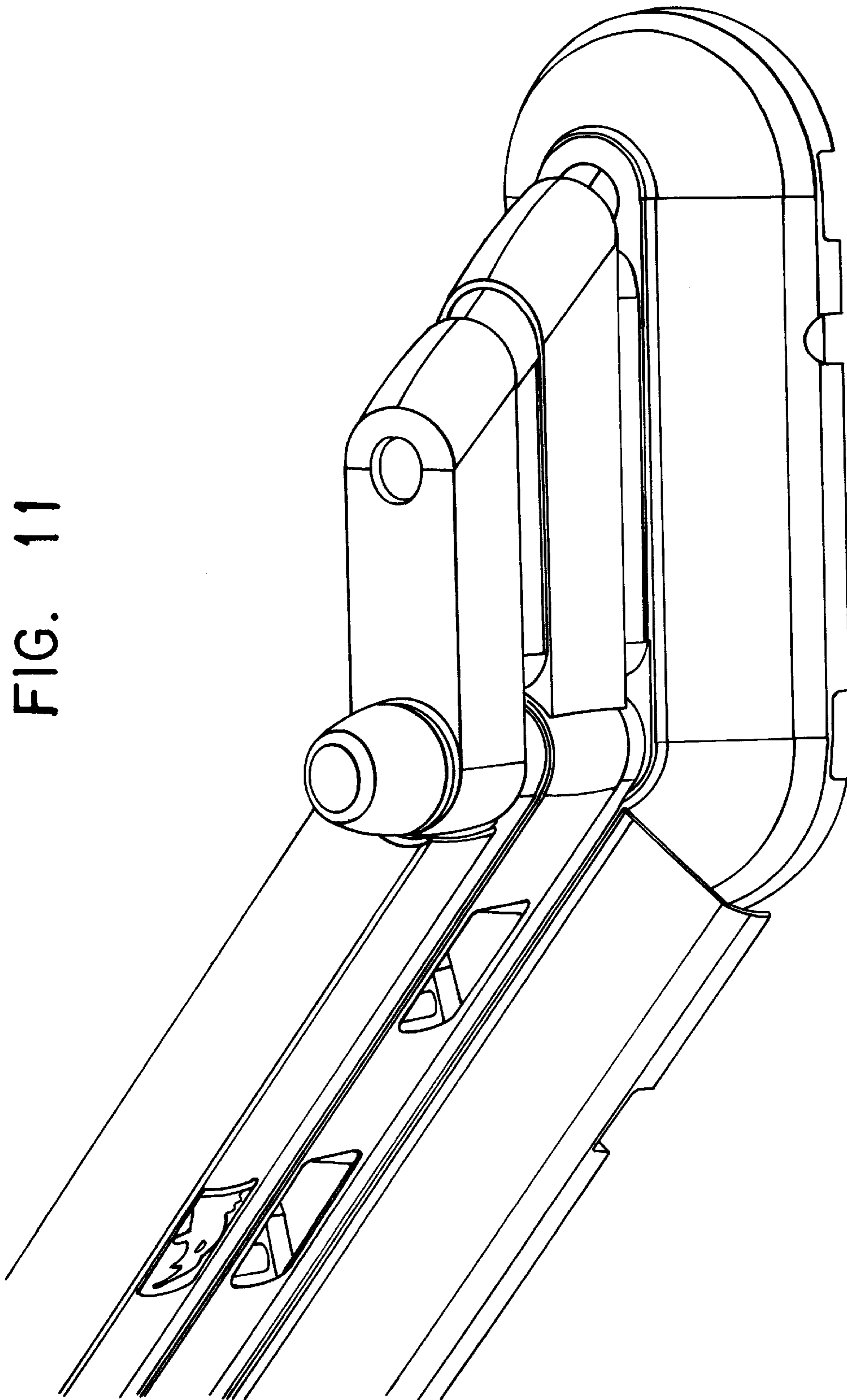

FIG. 12

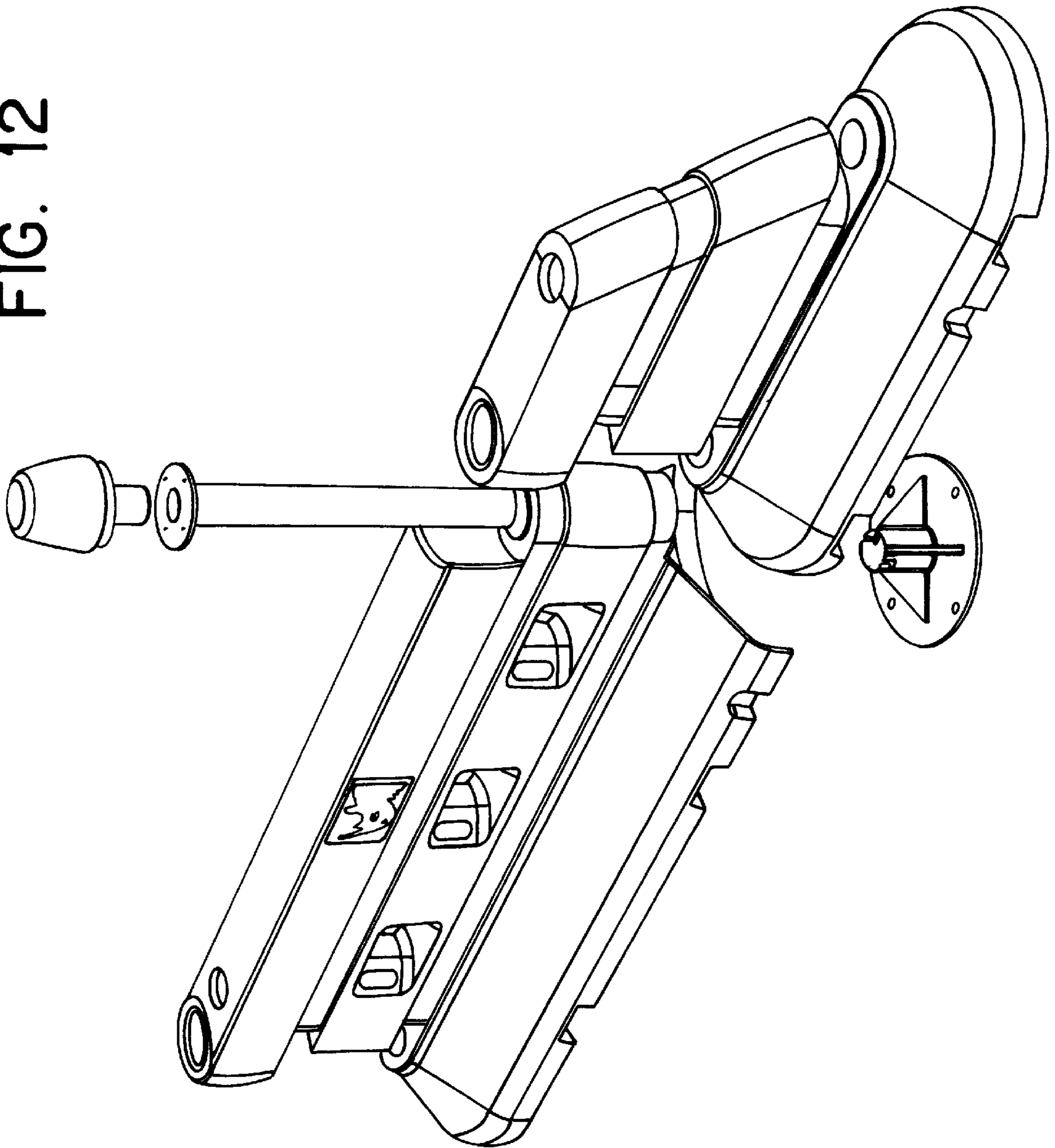

FIG. 13

