



US00D441337S

(12) **United States Design Patent**
Netz et al.

(10) **Patent No.:** **US D441,337 S**

(45) **Date of Patent:** **** May 1, 2001**

(54) **PORTION OF A MOTORCYCLE WHEEL**

(75) Inventors: **Louis N. Netz**, Grafton; **Alvin R. Zemlicka**, Elkhart Lake, both of WI (US)

(73) Assignee: **Harley-Davidson Motor Company**, Milwaukee, WI (US)

(**) Term: **14 Years**

(21) Appl. No.: **29/108,636**

(22) Filed: **Jul. 30, 1999**

(51) **LOC (7) Cl.** **12-16**

(52) **U.S. Cl.** **D12/204**

(58) **Field of Search** D12/204-211,
D12/126; 301/37.1, 64.1, 65

(56) **References Cited**

U.S. PATENT DOCUMENTS

- D. 298,224 * 10/1988 Yamada et al. D12/211 X
- D. 306,154 * 2/1990 Berg D12/204
- D. 310,191 * 8/1990 Yamada et al. D12/126

OTHER PUBLICATIONS

1995 Harley-Davidson, Genuine Parts & Accessories—pp. 108 and 109.

* cited by examiner

Primary Examiner—Stacia Cadmus

(74) *Attorney, Agent, or Firm*—Michael Best & Friedrich LLP

(57) **CLAIM**

We claim the ornamental design for a portion of a motorcycle wheel, as shown and described.

DESCRIPTION

FIG. 1 is a perspective view of a motorcycle having a wheel embodying the present invention.

FIG. 2 is an enlarged perspective view of the design shown in FIG. 1 from a different perspective than shown in FIG. 1; and,

FIG. 3 is a section view illustrating the profile of the design shown in FIG. 2.

The present application is directed to the design illustrated in the drawings. The other features of the drawings, such as the motorcycle shown in FIG. 1, are not considered part of the design sought to be patented, and have accordingly been shown in broken lines.

The design sought to be patented is not visible in the front, rear, top, or bottom views. Accordingly, these views have been omitted.

1 Claim, 2 Drawing Sheets

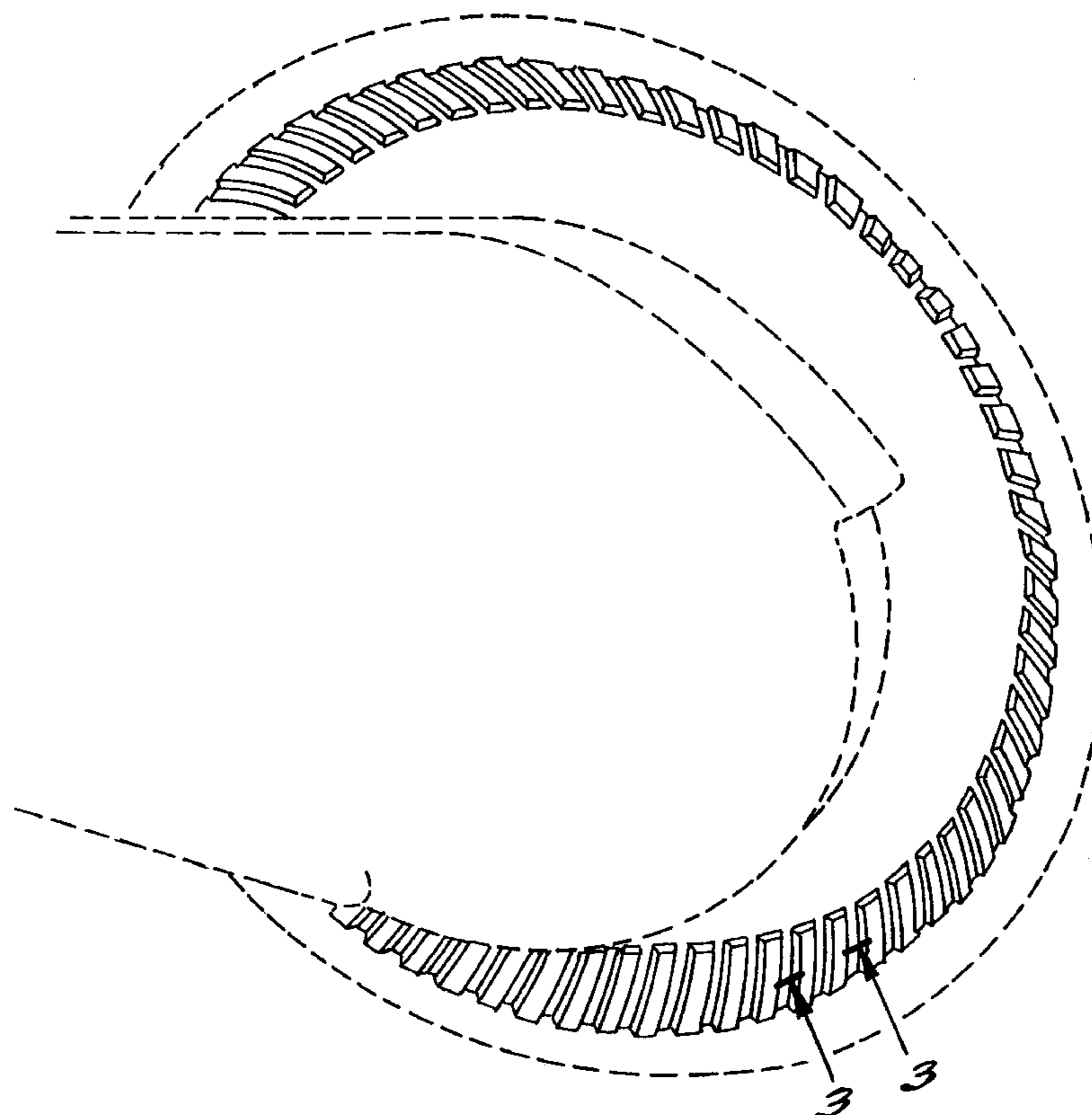

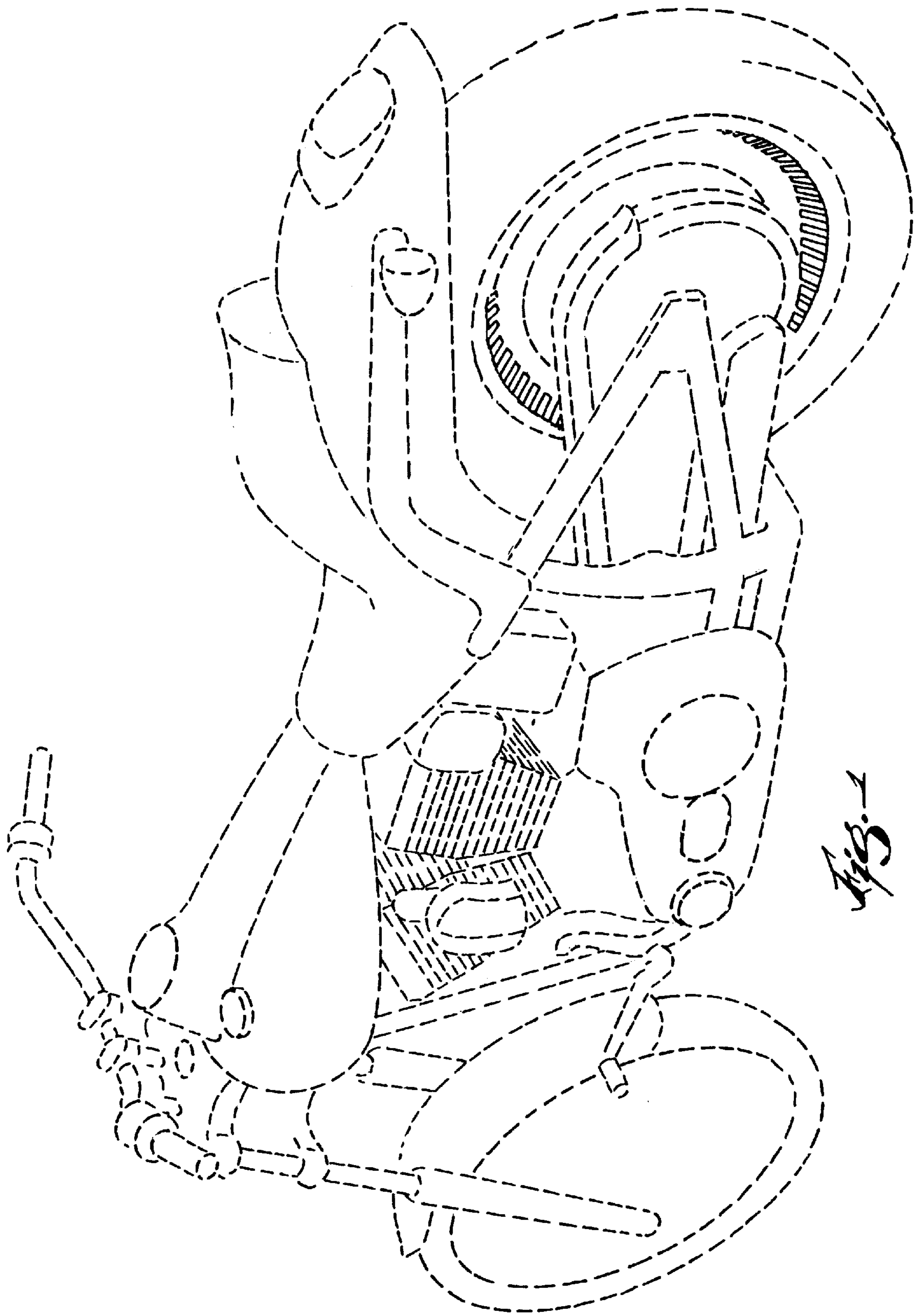

Fig. 2.

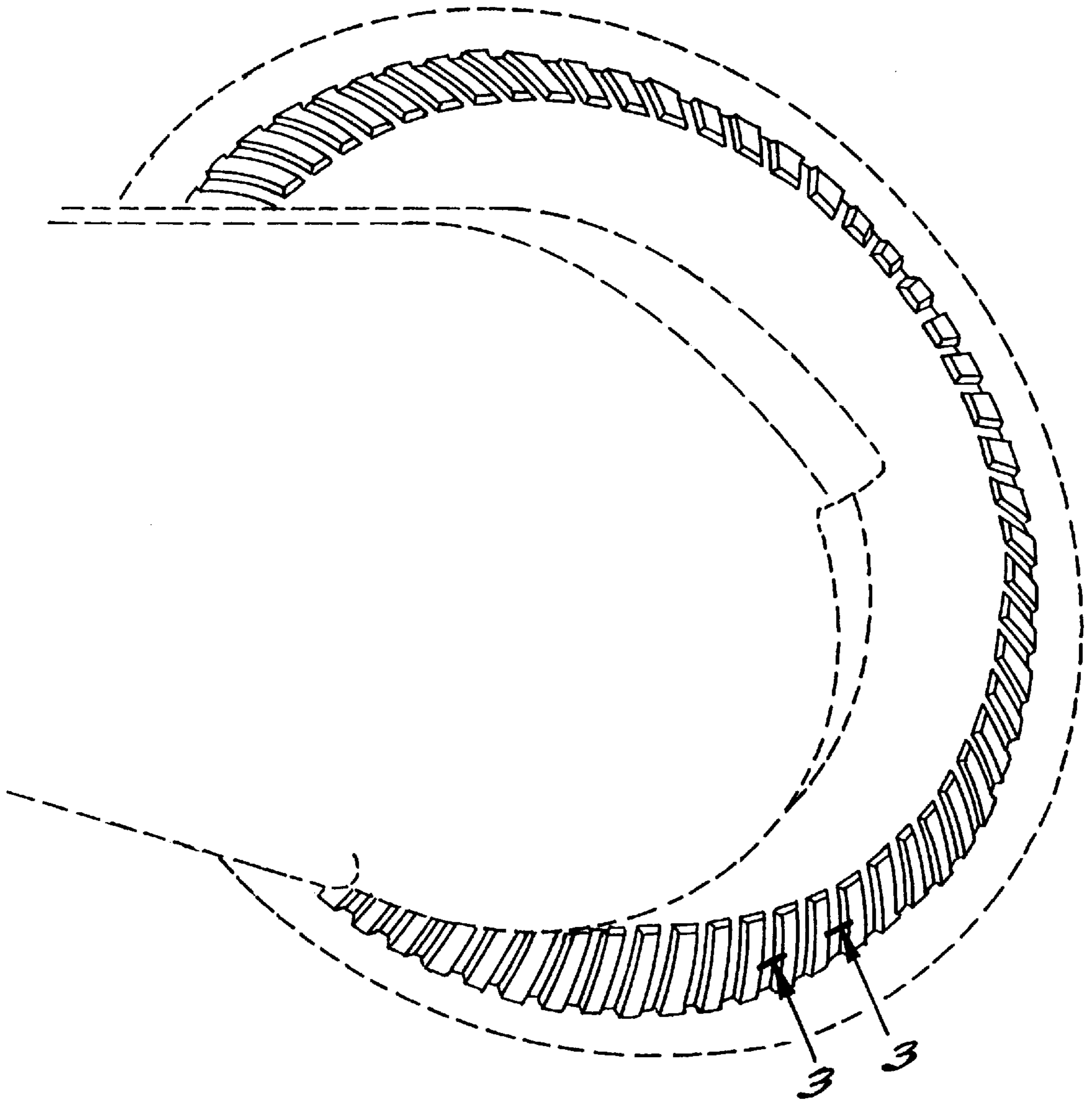

Fig. 3