



US00D441204S

(12) **United States Design Patent**
Bernich

(10) **Patent No.:** **US D441,204 S**

(45) **Date of Patent:** **** May 1, 2001**

(54) **ASYMMETRIC MODULE FOR A MODULAR SEATING SYSTEM**

5,470,128 11/1995 Kerkham .

* cited by examiner

(75) Inventor: **Thomas Bernich**, Brooklyn, NY (US)

Primary Examiner—Gary D. Watson

(73) Assignee: **Quinta Corporation**, Congers, NY (US)

(74) *Attorney, Agent, or Firm*—Blank Rome Comisky & McCauley LLP

(**) Term: **14 Years**

(57) **CLAIM**

(21) Appl. No.: **29/102,808**

The ornamental design for an asymmetric module for a modular seating system, as shown and described.

(22) Filed: **Apr. 1, 1999**

DESCRIPTION

(51) **LOC (7) Cl.** **06-01**

(52) **U.S. Cl.** **D6/334; D6/368; D6/335**

(58) **Field of Search** D6/334, 335, 336, D6/364, 365, 368, 374, 381, 500, 501, 502; 297/232, 440.1, 440.12

FIG. 1 shows a perspective view of a first type of asymmetric module for a modular seating system according to the present invention. The second type of asymmetric module is simply a mirror image of the first type.

FIG. 2 shows a front view of the first type of asymmetric module.

FIG. 3 shows a back view of the first type of asymmetric module.

FIG. 4 shows a left view of the first type of asymmetric module.

FIG. 5 shows a right view of the first type of asymmetric module.

FIG. 6 shows a top view of the first type of asymmetric module.

FIG. 7 shows a bottom view of the first type of asymmetric module; and,

FIG. 8 shows one way in which the first and second types of modules can be arranged into a modular seating system.

The broken lines shown in FIG. 8 are for illustrative purposes only and form no part of the claimed design.

(56) **References Cited**

U.S. PATENT DOCUMENTS

| | | | | | |
|------------|---|---------|-----------------|-------|------------|
| D. 260,582 | * | 9/1981 | Lüthy | | D6/381 |
| D. 293,169 | | 12/1987 | Salvato | . | |
| D. 330,464 | | 10/1992 | Dettinger | . | |
| D. 335,035 | | 4/1993 | Floyd | . | |
| D. 336,787 | | 6/1993 | Gibson | . | |
| D. 352,182 | * | 11/1994 | Yoshimura | | D6/368 |
| D. 352,837 | * | 11/1994 | Pugh | | D6/336 |
| D. 360,311 | | 7/1995 | Stamberg et al. | . | |
| D. 362,128 | * | 9/1995 | Natuzzi et al. | | D6/381 |
| D. 369,495 | | 5/1996 | Mourgue | . | |
| D. 378,028 | * | 2/1997 | Schefcik | | D6/334 |
| 3,312,503 | * | 4/1967 | Suzuki | | D6/368 X |
| 3,973,800 | | 8/1976 | Kogan | . | |
| 4,085,970 | * | 4/1978 | Klein | | 297/440.12 |
| 4,804,230 | * | 2/1989 | Friedman | | 297/440.12 |

1 Claim, 4 Drawing Sheets

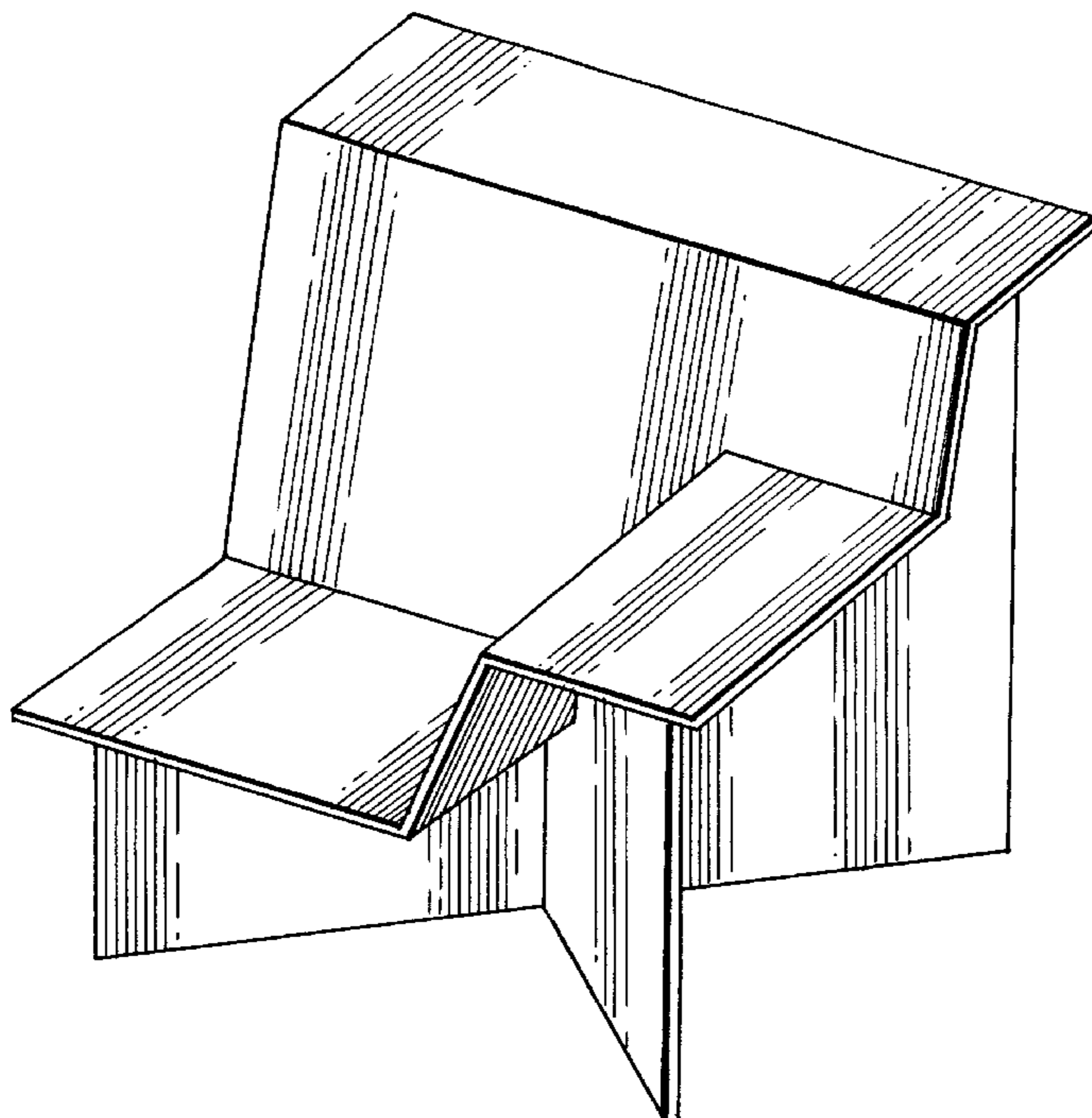

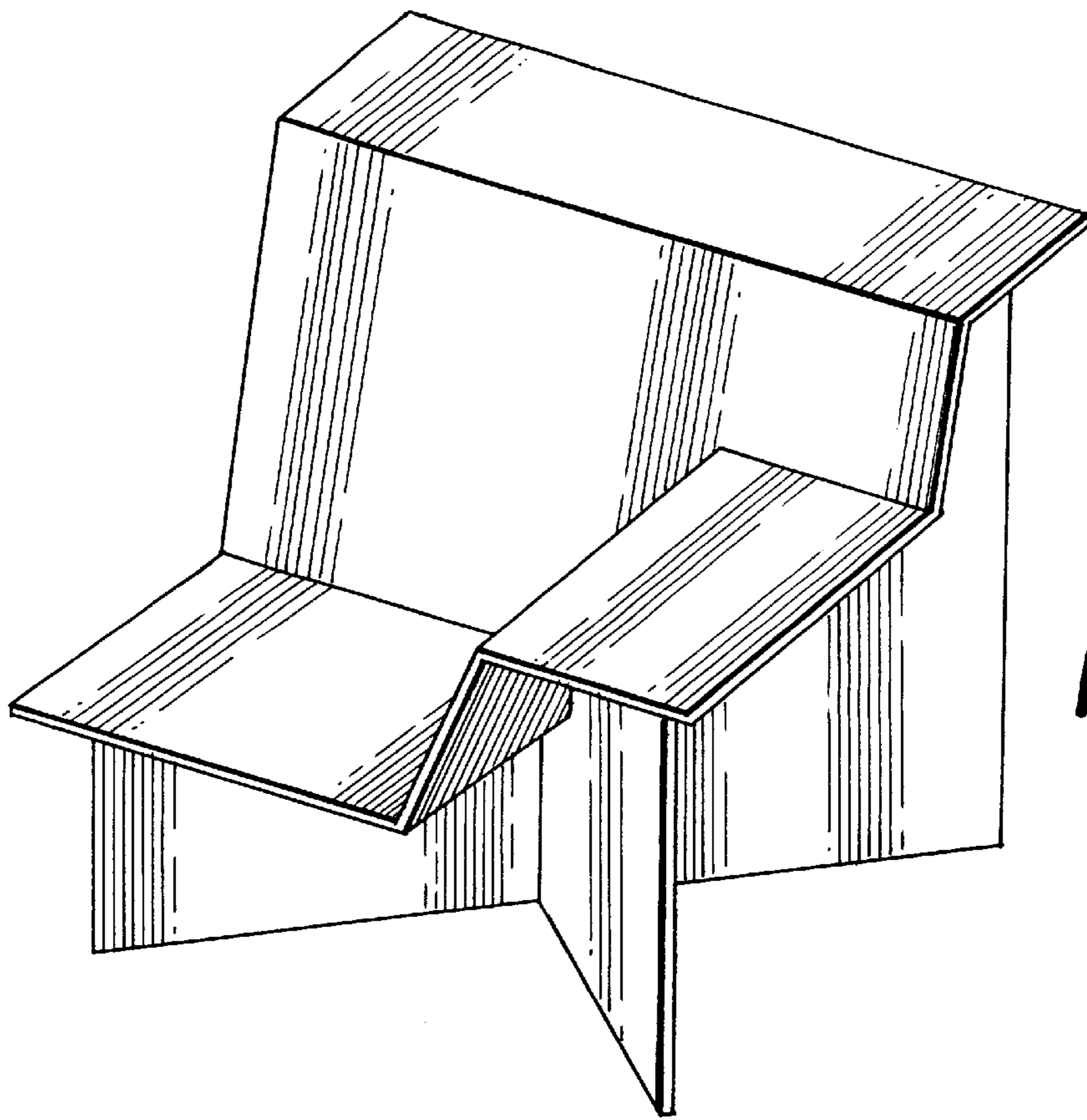

FIG. 1

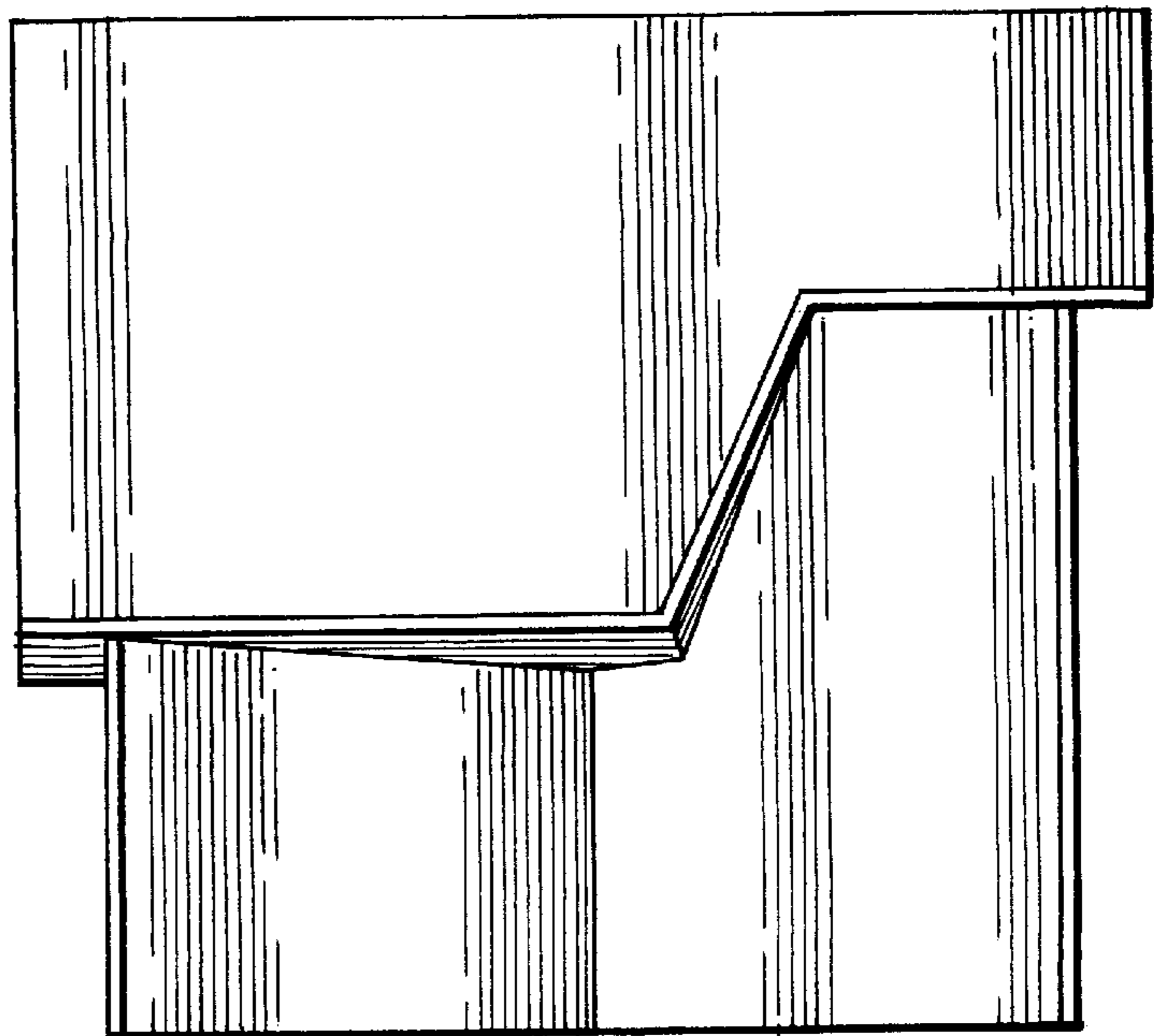

FIG. 2

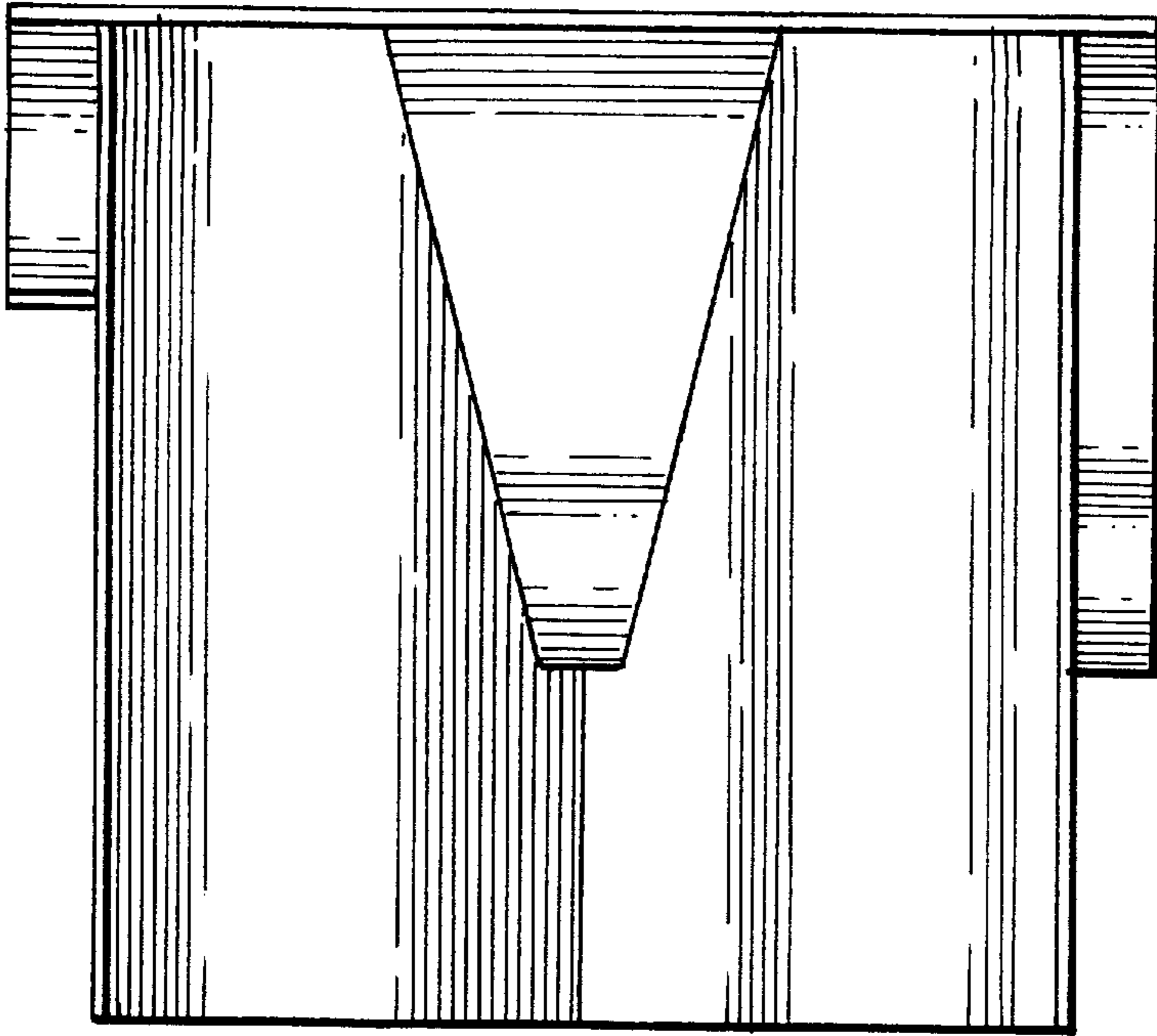

FIG. 3

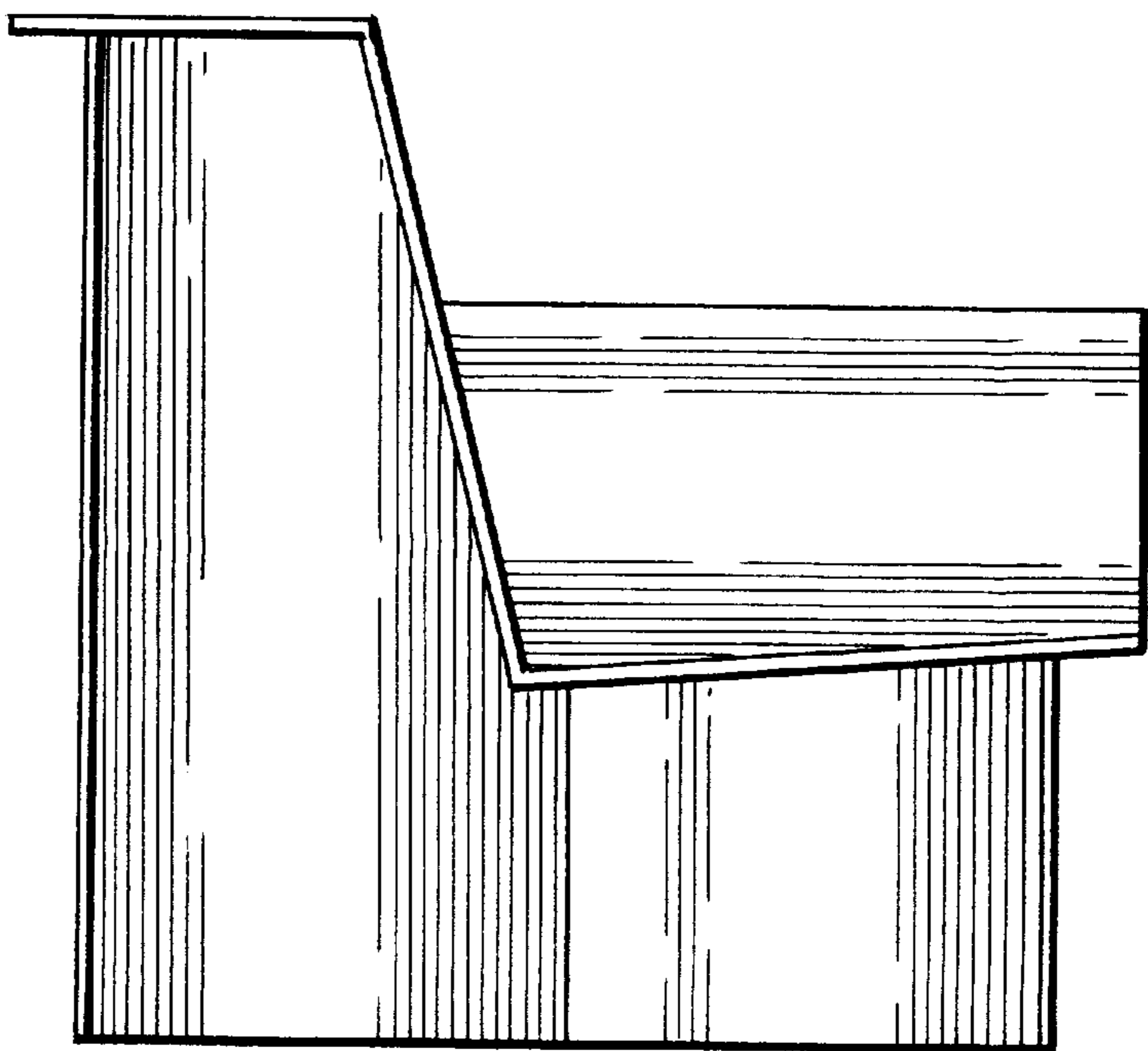

FIG. 4

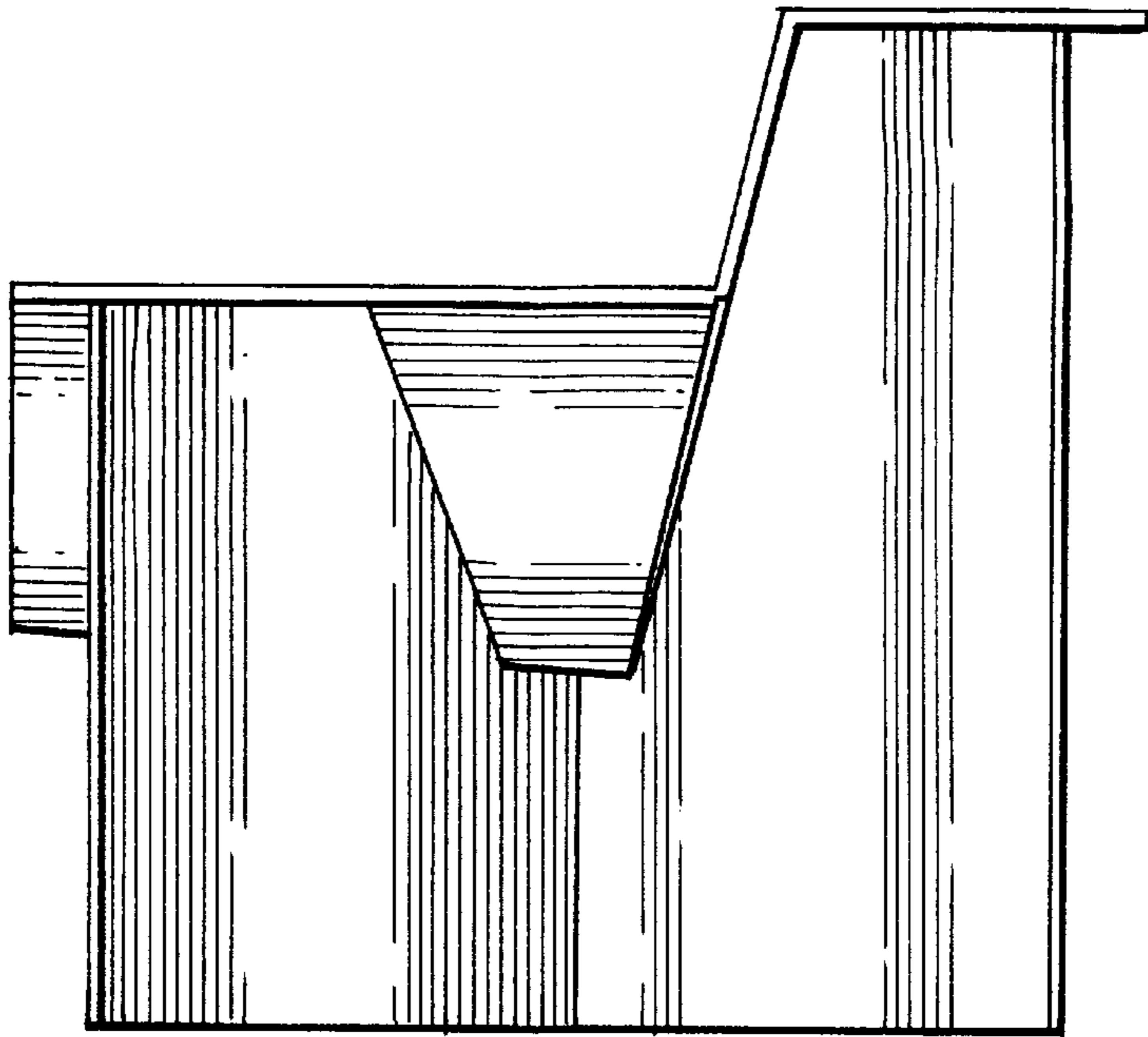

FIG. 5

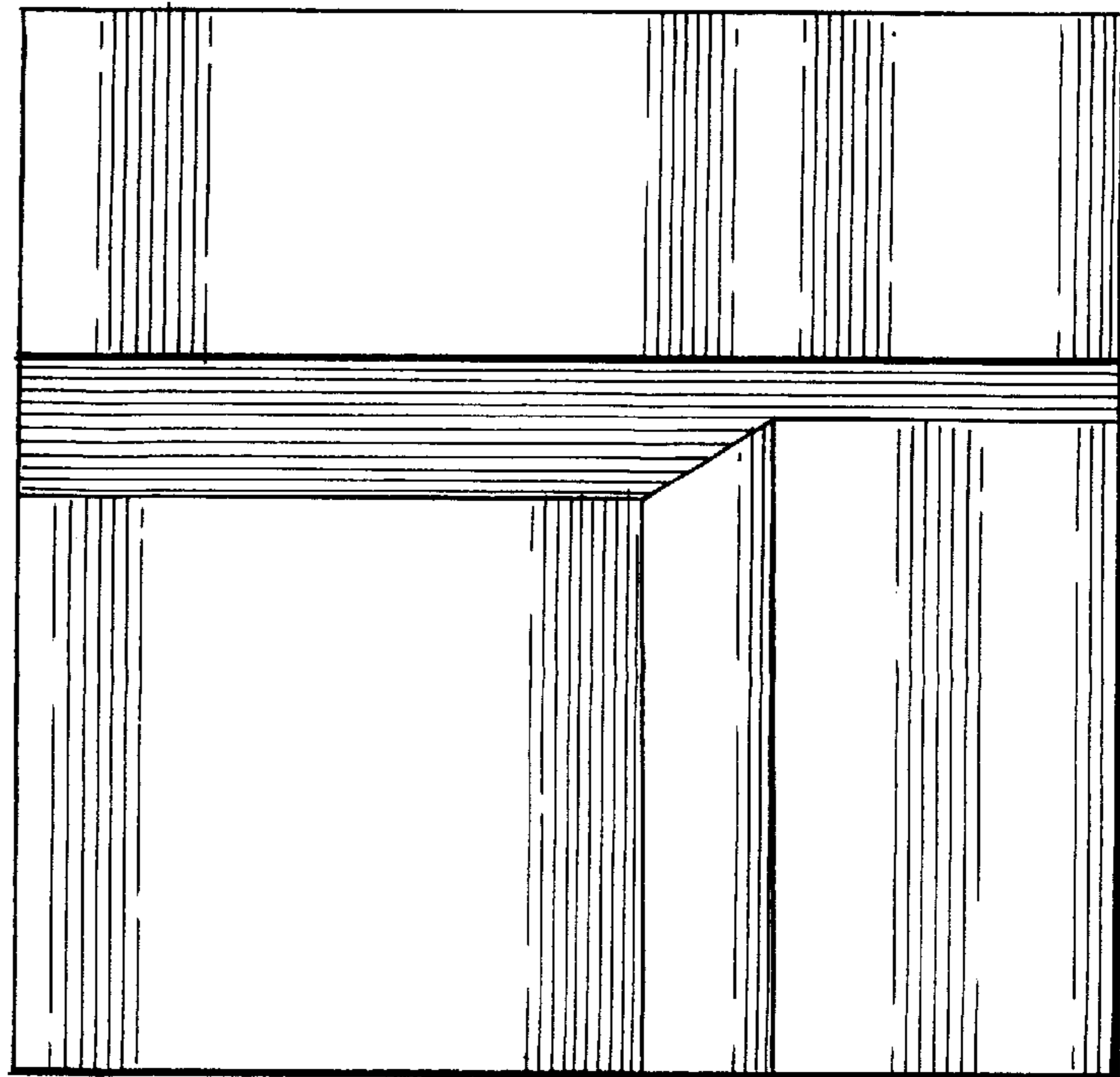

FIG. 6

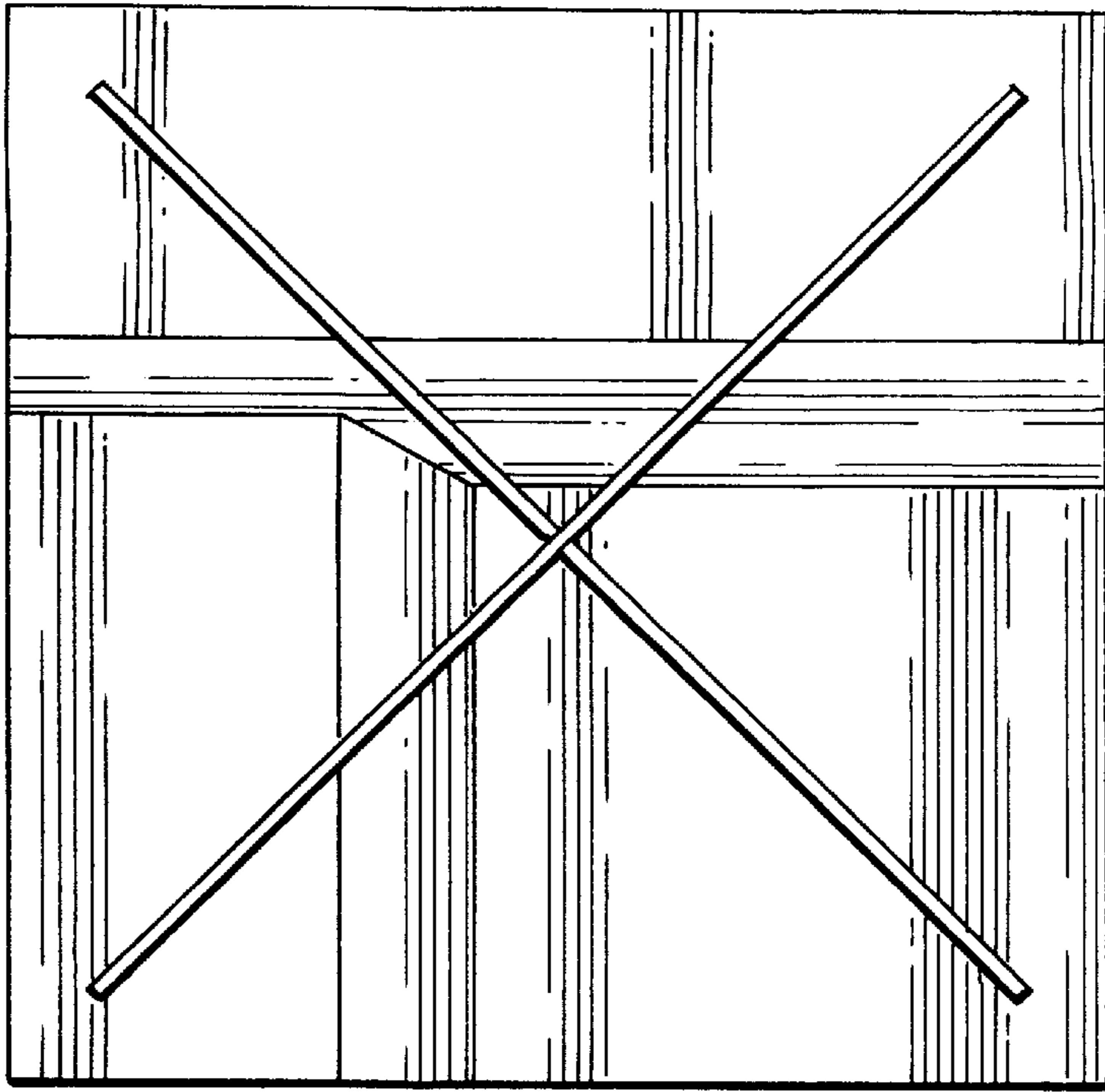

FIG. 7

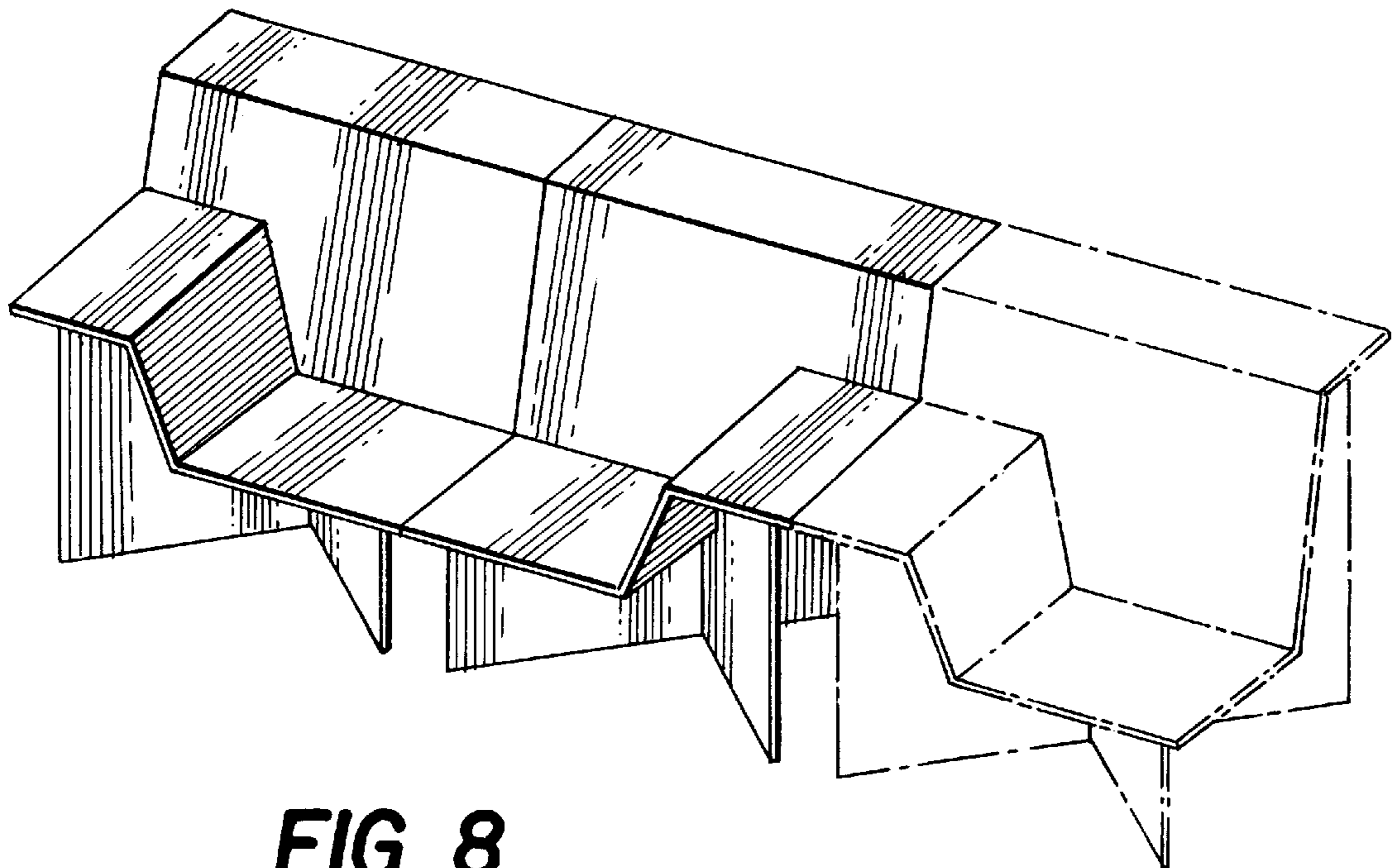

FIG. 8