



US00D440990S

(12) **United States Design Patent**
Asai

(10) **Patent No.:** **US D440,990 S**

(45) **Date of Patent:** **** Apr. 24, 2001**

(54) **LINEAR-MOVING APPARATUS**

FOREIGN PATENT DOCUMENTS

(75) Inventor: **Go Asai**, Toride (JP)

1074626 6/2000 (JP) .

(73) Assignee: **SMC Kabushiki Kaisha**, Tokyo (JP)

* cited by examiner

(**) Term: **14 Years**

Primary Examiner—Antoine Duval Davis

(21) Appl. No.: **29/121,684**

(74) *Attorney, Agent, or Firm*—Frishauf, Holtz, Goodman, Langer & Chick, P.C.

(22) Filed: **Apr. 12, 2000**

(57) **CLAIM**

(30) **Foreign Application Priority Data**

The ornamental design for a linear-moving apparatus, as shown and described.

Oct. 18, 1999 (JP) 11-28530

DESCRIPTION

(51) **LOC (7) Cl.** **15-09**

FIG. 1 is a top, front and right-side perspective view of a linear-moving apparatus showing my new design;

(52) **U.S. Cl.** **D15/143; D15/199**

FIG. 2 is a front view thereof;

(58) **Field of Search** D15/143, 199;

FIG. 3 is a rear view thereof;

74/89.15, 490.09; 310/20, 80

FIG. 4 is a right side view thereof, the left side view being a mirror image;

(56) **References Cited**

FIG. 5 is a top plan view thereof; and,

U.S. PATENT DOCUMENTS

FIG. 6 is a bottom plan view thereof.

D. 365,352 * 12/1995 Miyamoto et al. .

1 Claim, 4 Drawing Sheets

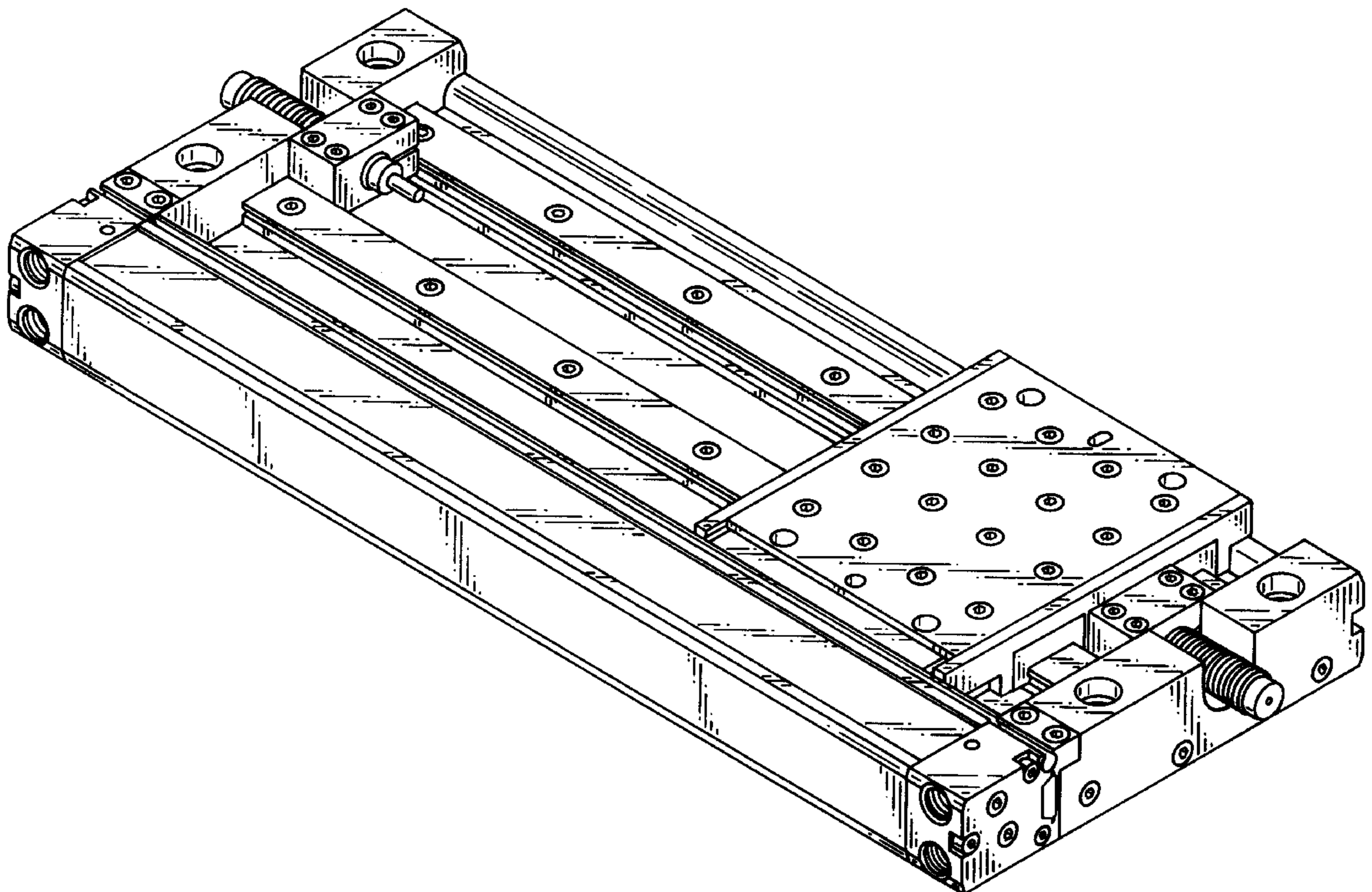

FIG. 1

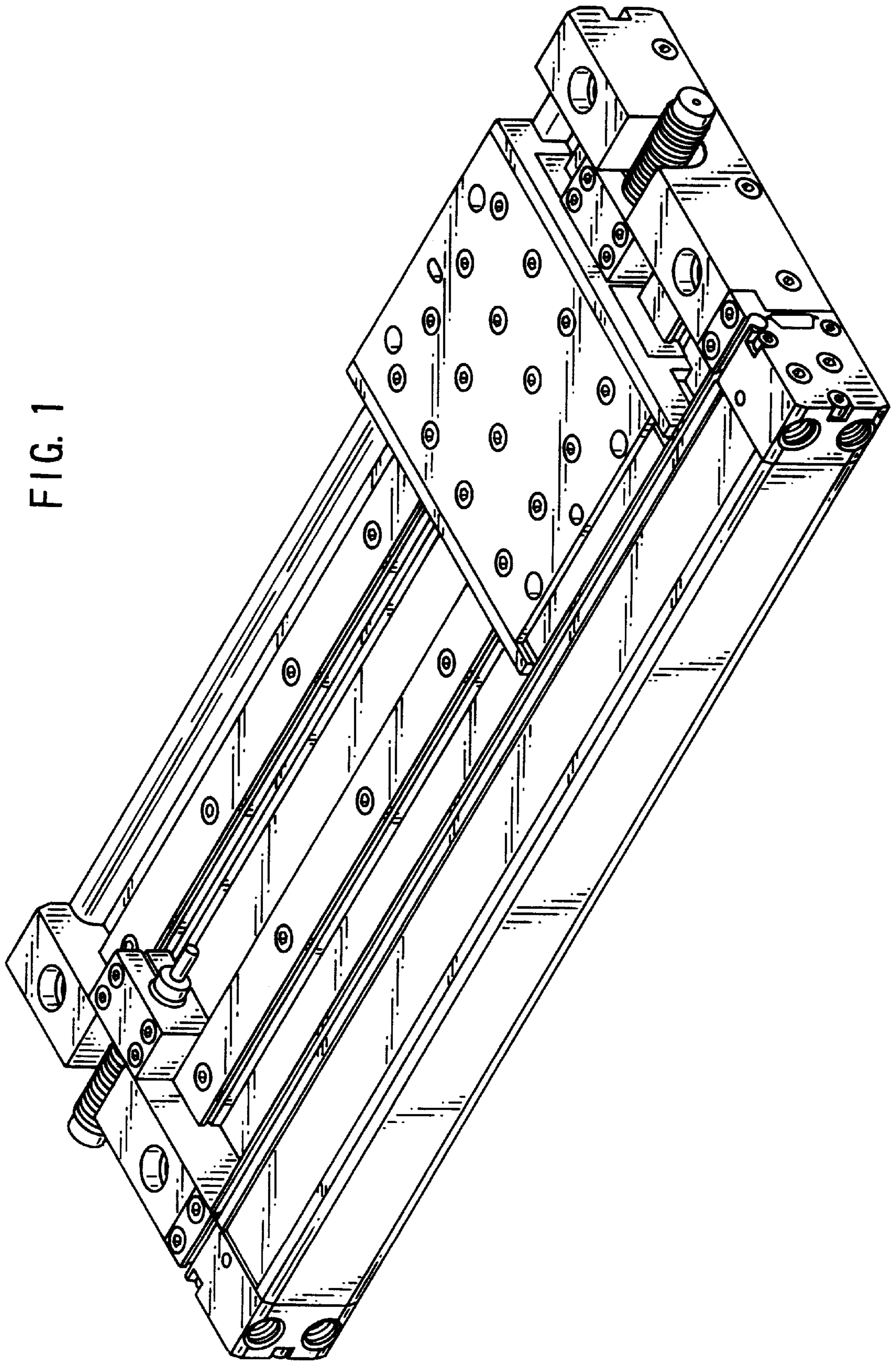

FIG. 2

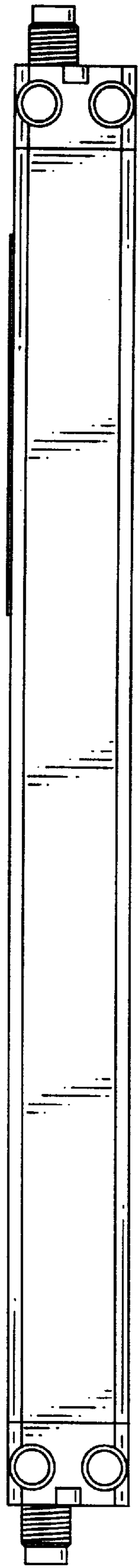

FIG. 3

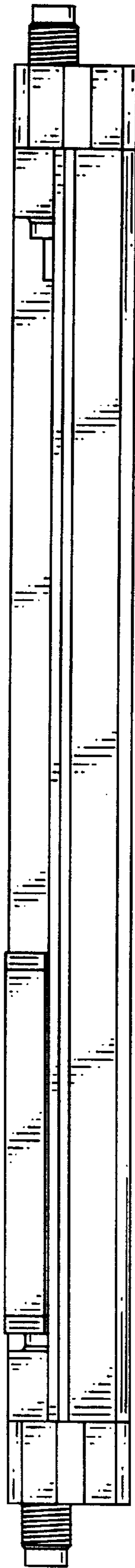

FIG. 4

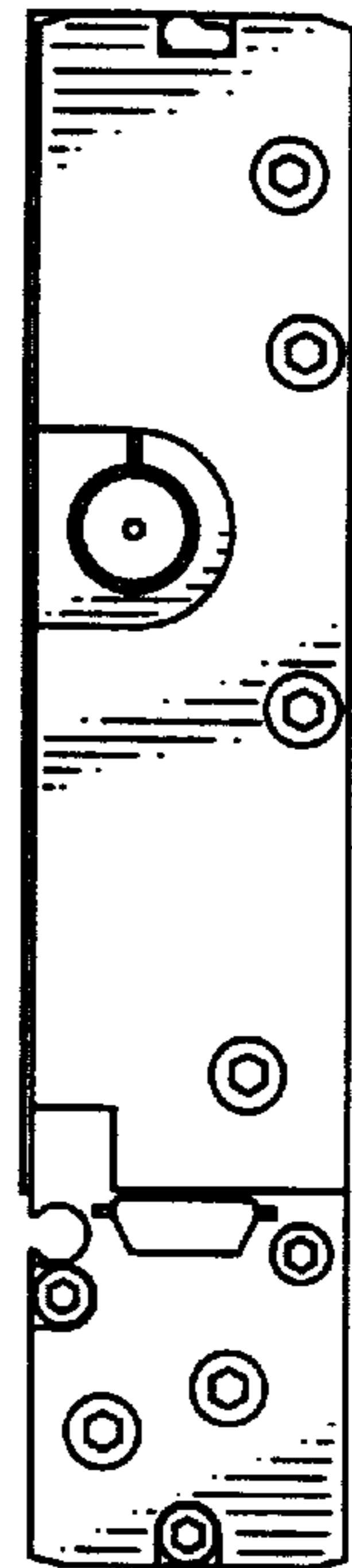

FIG. 5

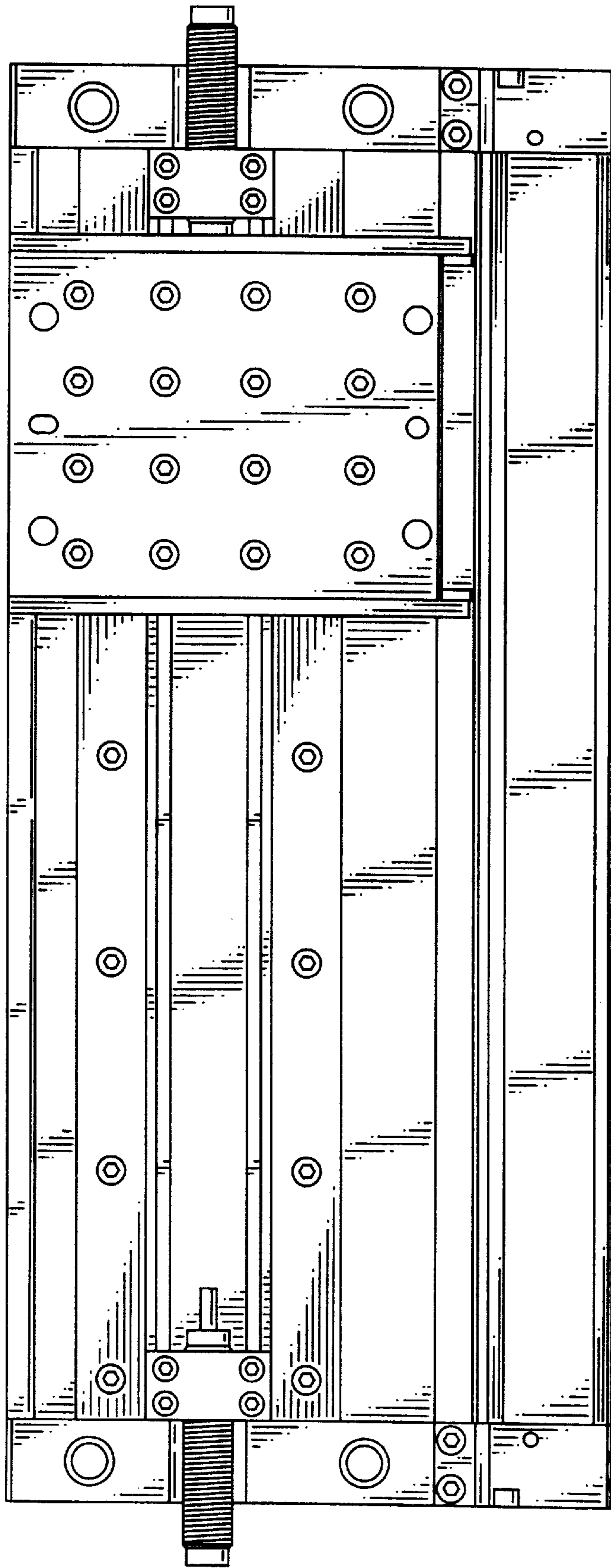

FIG. 6

