



US00D440983S

(12) **United States Design Patent**  
**Miller et al.**

(10) **Patent No.:** **US D440,983 S**

(45) **Date of Patent:** **\*\* Apr. 24, 2001**

(54) **COUPLER FOR BUCKET EXCAVATORS**

(76) Inventors: **Ronald Keith Miller; Gary Miller; Doreen Jacqueline Miller**, all of Addison Industrial Estate, Blaydon, Tyne and Wear (GB), NE21 4TE

(\*\*) Term: **14 Years**

(21) Appl. No.: **29/106,734**

(22) Filed: **Jun. 21, 1999**

(51) **LOC (7) Cl.** ..... **15-04**

(52) **U.S. Cl.** ..... **D15/28; D15/32**

(58) **Field of Search** ..... **D15/10, 22-25, D15/28, 32; 248/200; 414/723**

(56) **References Cited**

**U.S. PATENT DOCUMENTS**

D. 272,069	*	1/1984	Larsson	.....	D15/28
D. 272,070	*	1/1984	Larsson	.....	D15/28
D. 272,250	*	1/1984	Larsson	.....	D15/28
5,332,353	*	7/1994	Arnold	.....	414/723
5,382,110	*	1/1995	Perotto et al.	.....	414/723
5,484,250	*	1/1996	Gilmore, Jr. et al.	.....	414/723
5,791,863	*	8/1998	Droegemueller	.....	414/723
5,820,332	*	10/1998	Philips et al.	.....	414/723
5,951,192	*	9/1999	Collins	.....	414/723
5,966,850	*	10/1999	Horton	.....	414/723

**OTHER PUBLICATIONS**

Quality Attachments built by the Experts—Miller Brochure, undated.

The BHL Coupler New from Miller. In a Word . . . Versatility—Miller Brochure, undated.

Its Time to make that Change. As Simple As . . . —Miller Brochure, undated.

The Mechanical Coupler The Construction Industry Has Been Waiting For—Miller Brochure, undated.

Millers Bauma Success—brochure from Euro Plant Sales Ltd. (Plantman) undated.

\* cited by examiner

*Primary Examiner*—Sandra L. Morris

(74) *Attorney, Agent, or Firm*—Harter, Secrest & Emery LLP; Stephen B. Salai, Esq.; Brian B. Shaw, Esq.

(57) **CLAIM**

The ornamental design for a coupler for bucket excavators, as shown and described.

**DESCRIPTION**

FIG. 1 is a top right side perspective view of a coupler for bucket excavators, showing our new design;

FIG. 2 is a top rear left side perspective view thereof;

FIG. 3 is a left side view;

FIG. 4 is a top plan view;

FIG. 5 is a front elevation;

FIG. 6 is a rear elevation;

FIG. 7 is a bottom plan view with parts removed for clarity; and,

FIG. 8 is a bottom front right side perspective view with parts removed for clarity.

**1 Claim, 4 Drawing Sheets**

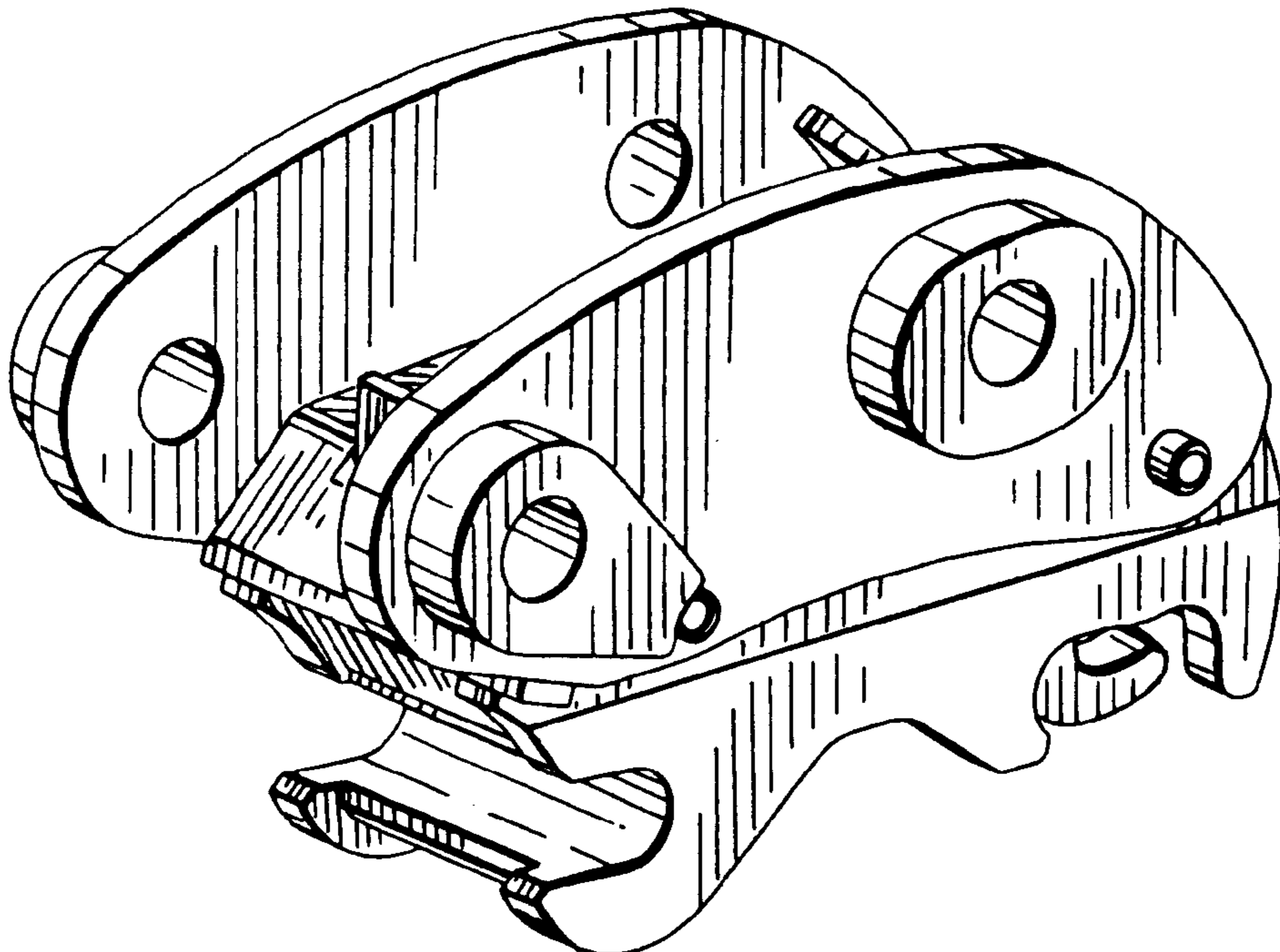

*FIG. 1*

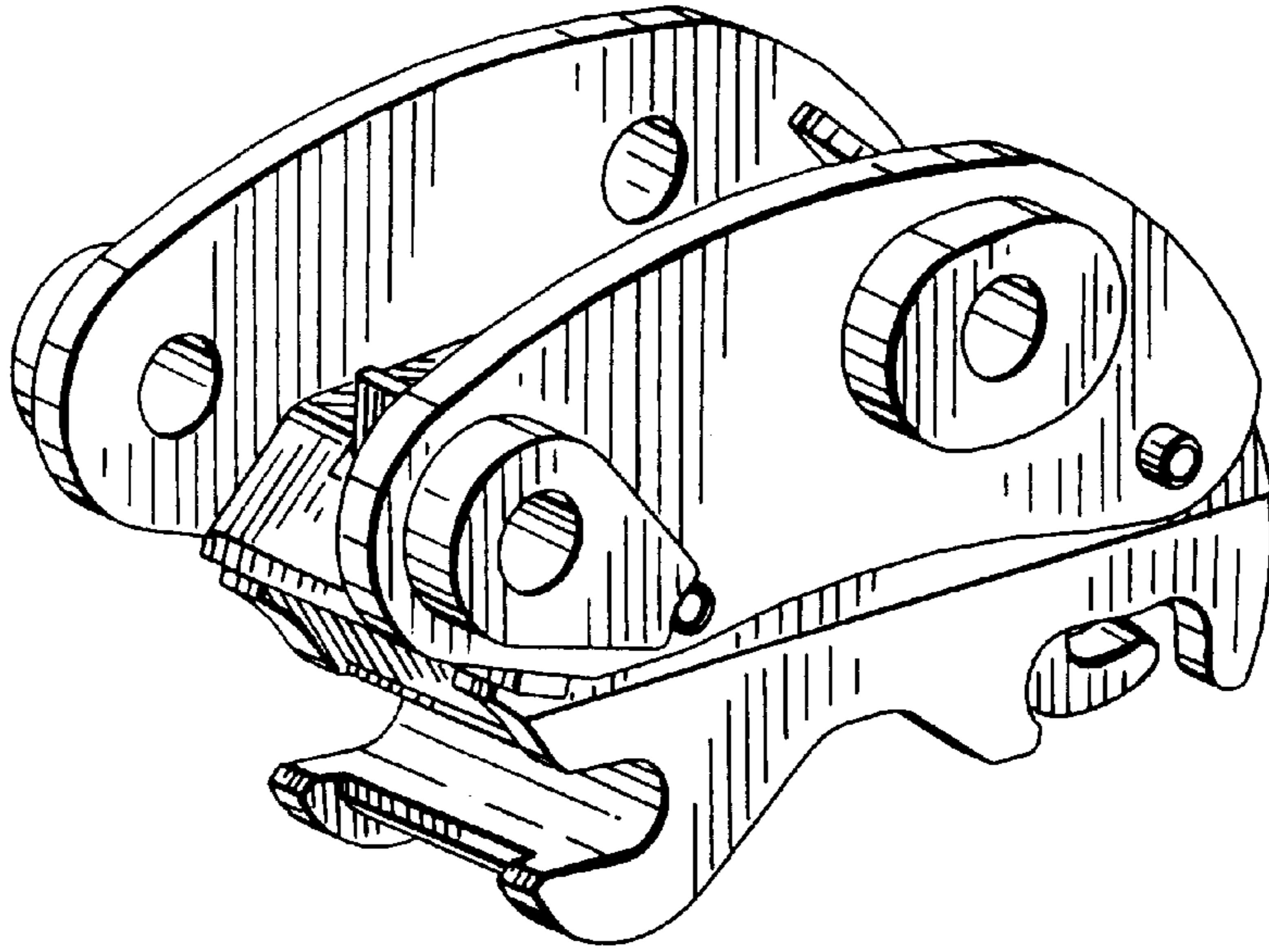

*FIG. 2*

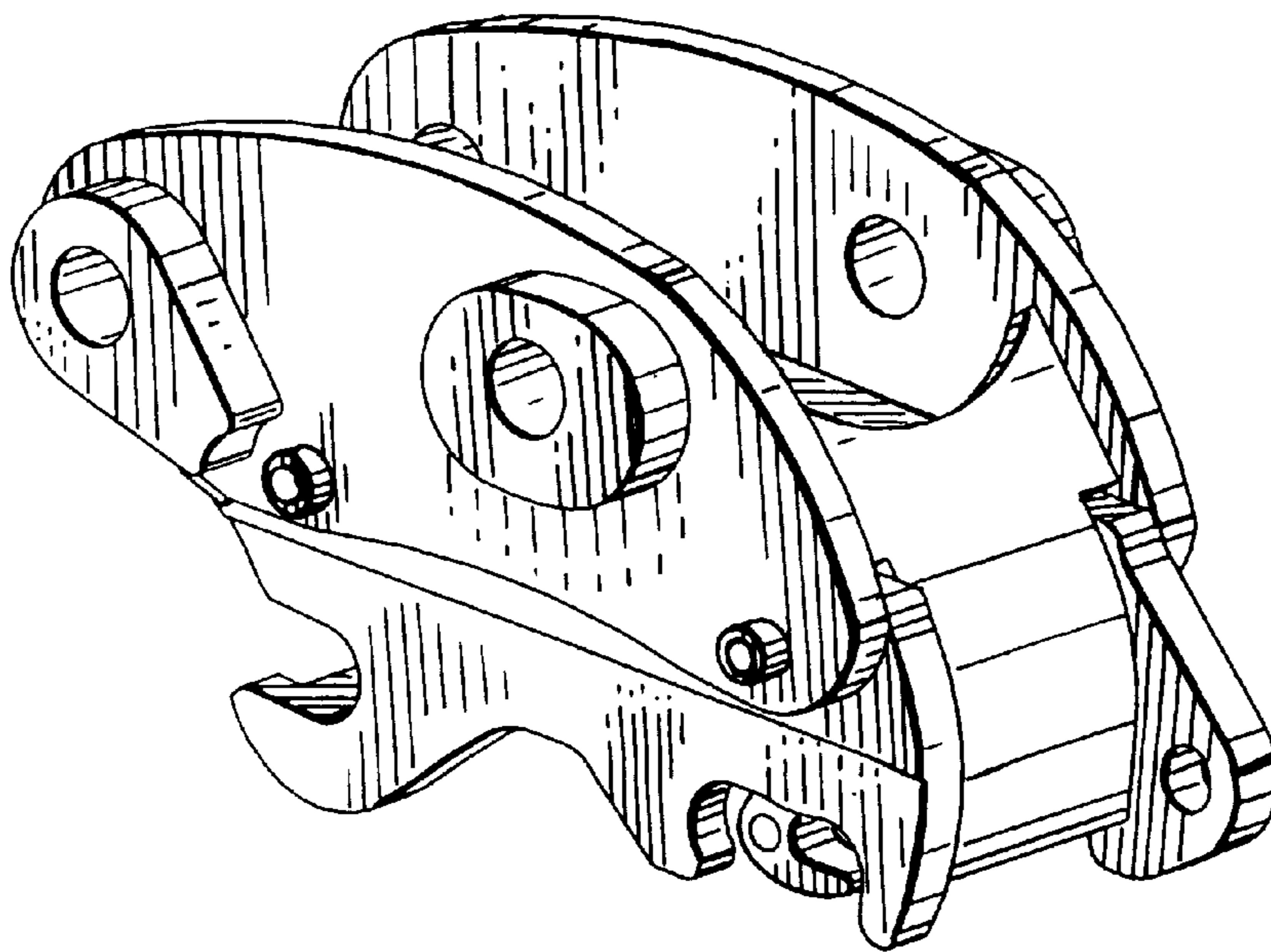

*FIG. 3*

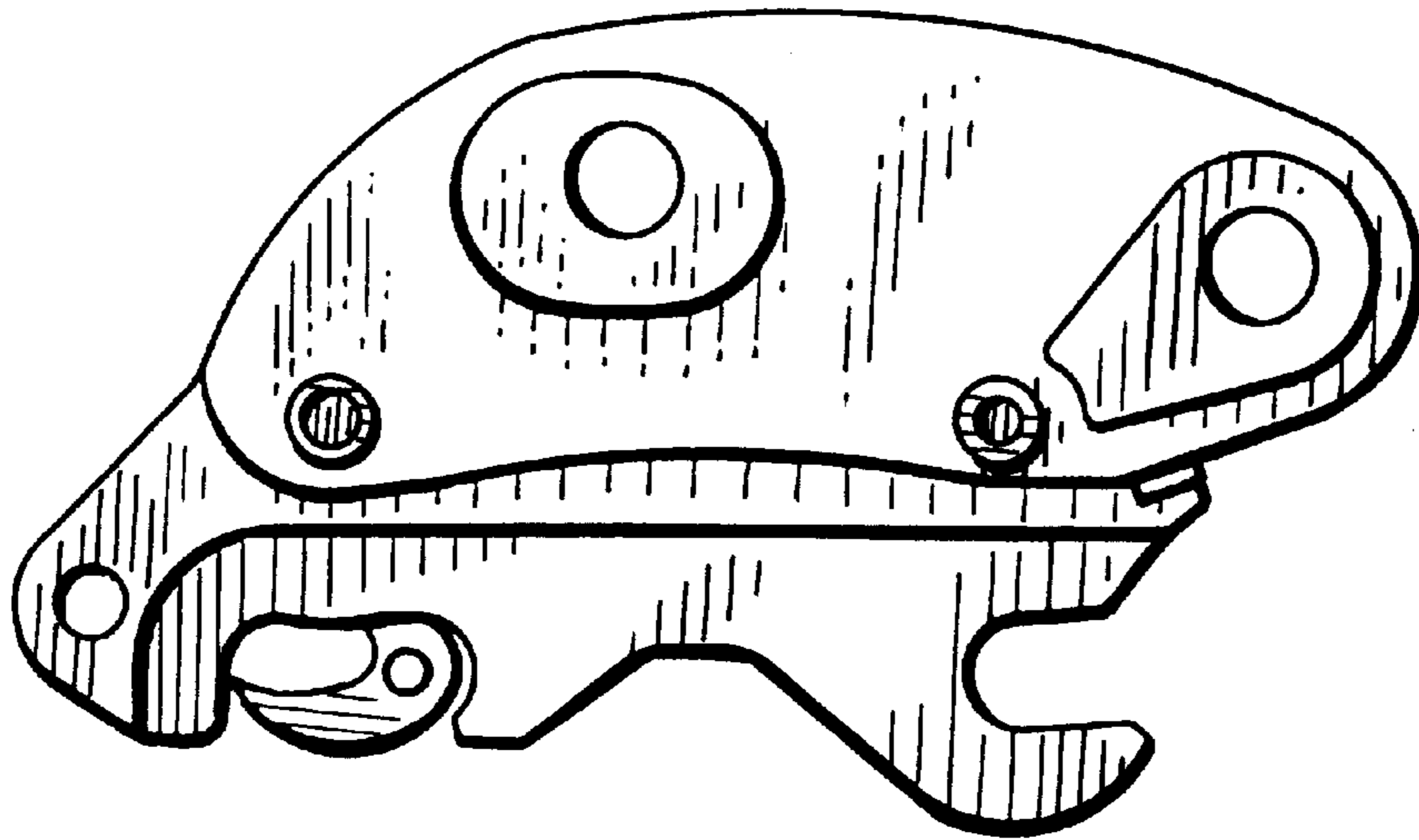

*FIG. 4*

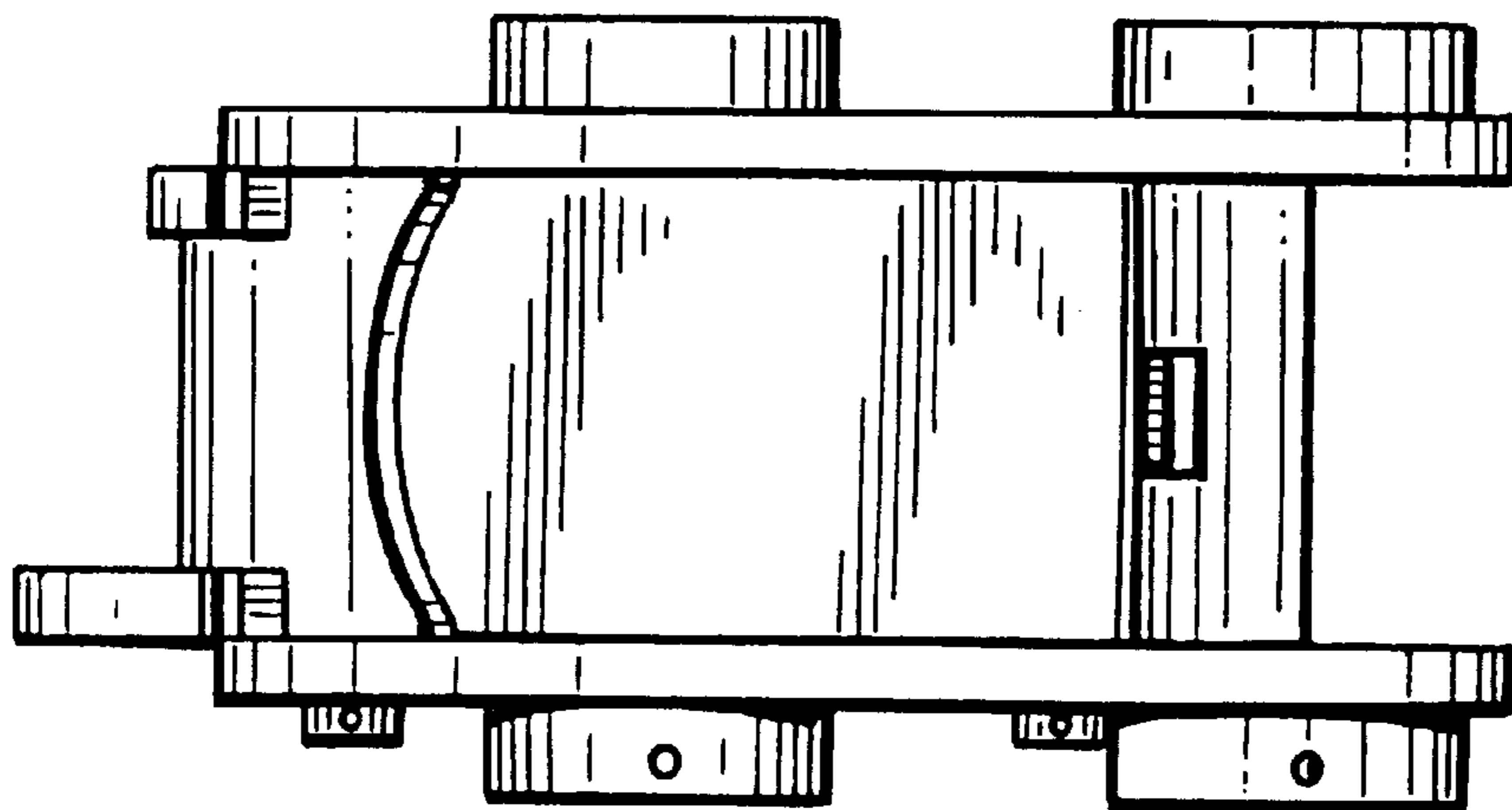

*FIG. 5*

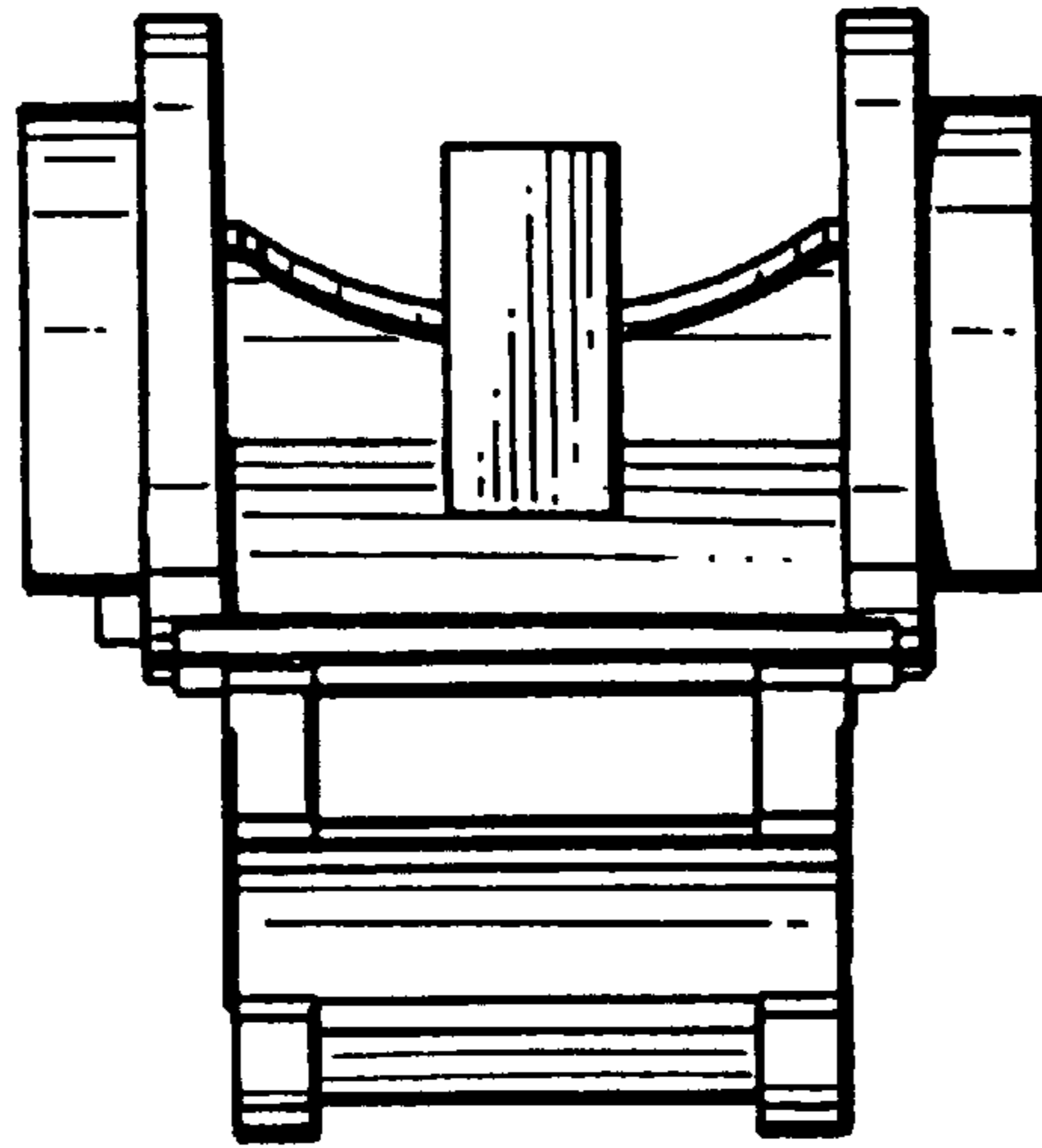

*FIG. 6*

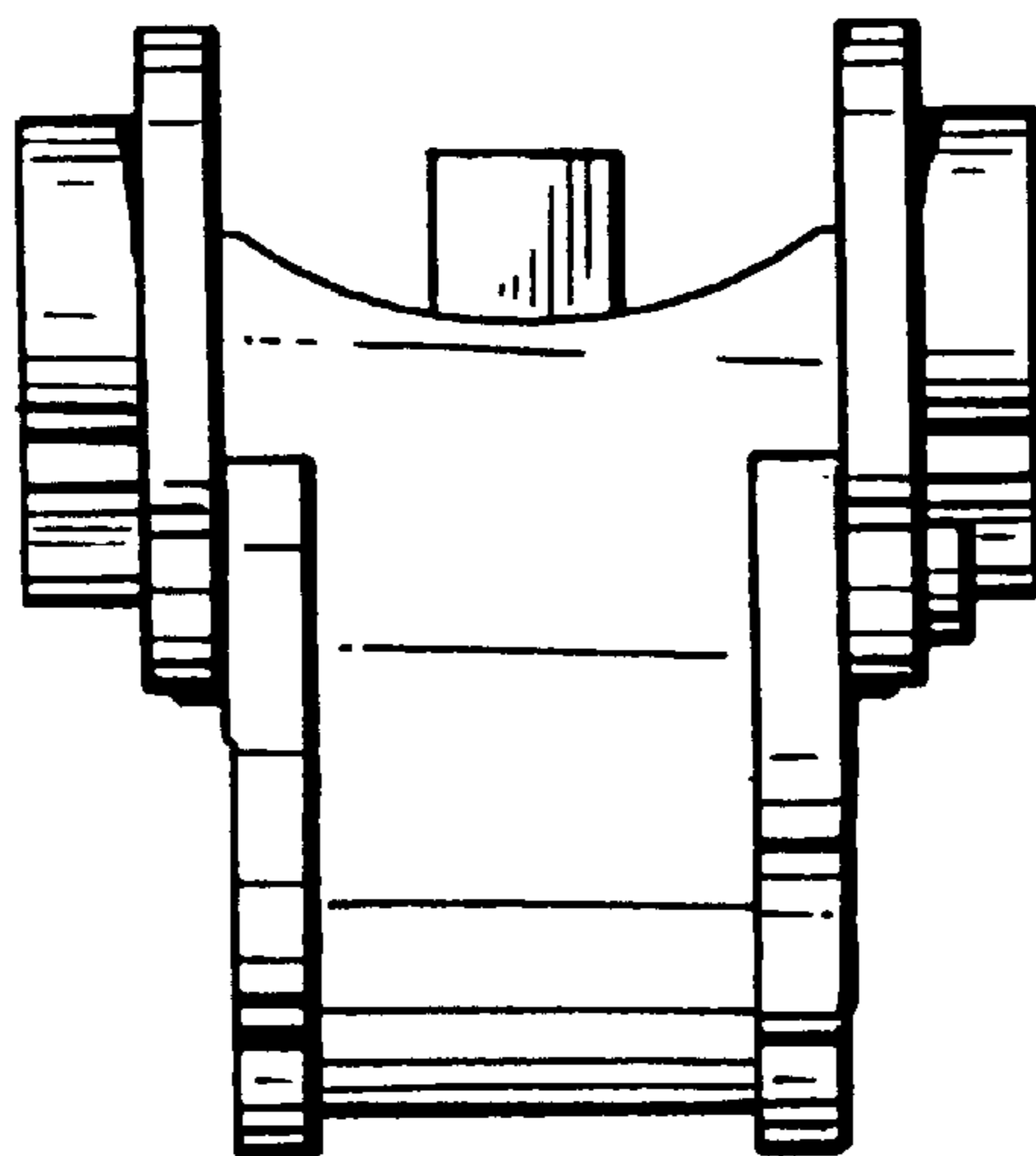

*FIG. 7*

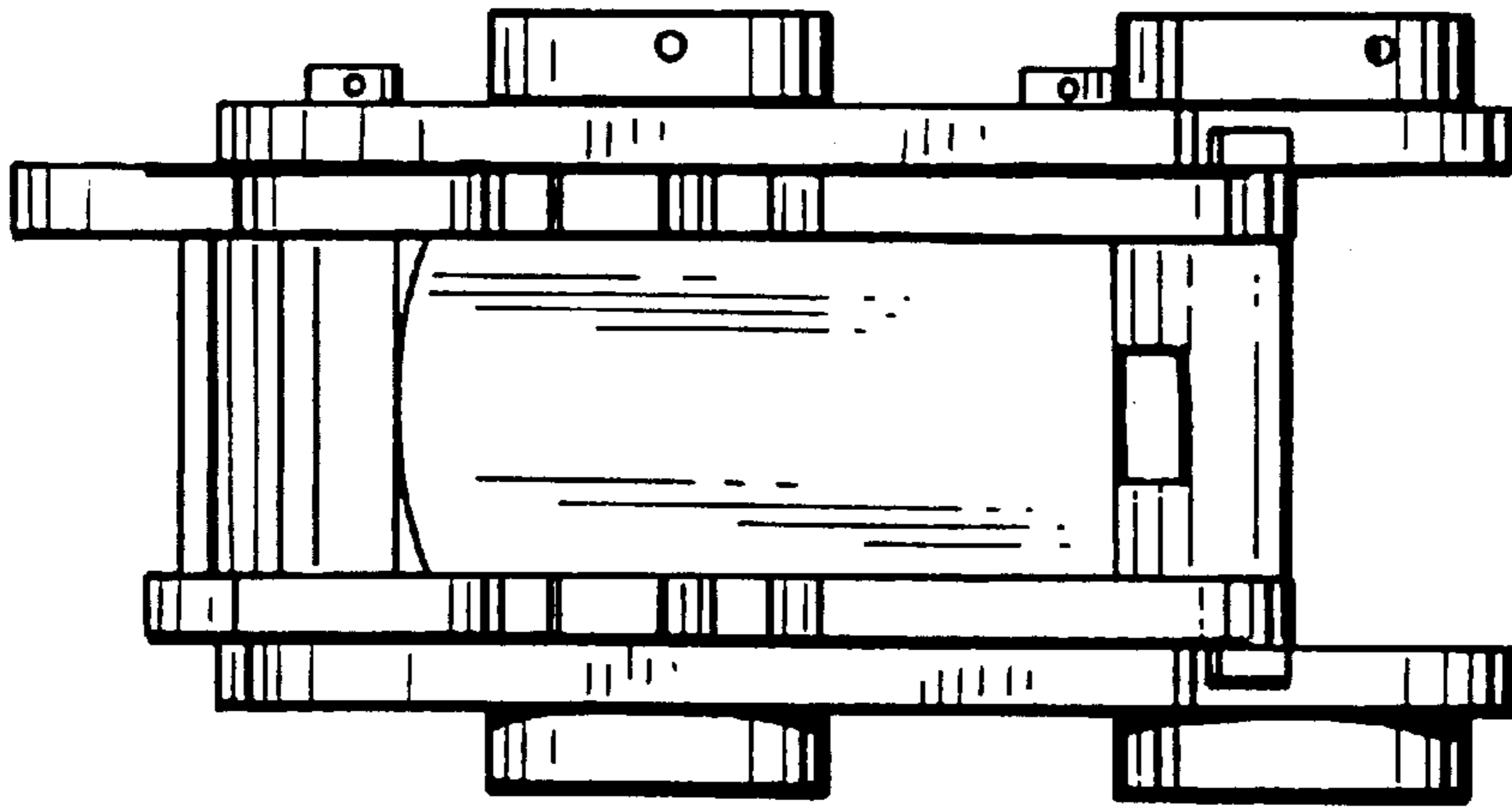

*FIG. 8*

