



US00D440934S

(12) **United States Design Patent**
Cataldo

(10) **Patent No.:** **US D440,934 S**

(45) **Date of Patent:** **** Apr. 24, 2001**

(54) **MOTORCYCLE TOWING UNIT**

FOREIGN PATENT DOCUMENTS

(76) Inventor: **Roger W. Cataldo**, 6012 NW. 69th
Ave., Tamarac, FL (US) 33321

438044 11/1967 (CH) .
2515585 5/1983 (FR) .

(**) Term: **14 Years**

* cited by examiner

(21) Appl. No.: **29/130,460**

Primary Examiner—Alan P. Douglas

Assistant Examiner—Linda Brooks

(22) Filed: **Oct. 3, 2000**

(74) *Attorney, Agent, or Firm*—Stephen R. Greiner

(51) **LOC (7) Cl.** **12-16**

(57) **CLAIM**

(52) **U.S. Cl.** **D12/408**

The ornamental design for a motorcycle towing unit, as shown and described.

(58) **Field of Search** D12/406, 408,
D12/115; 280/969, 202, 292, 204, 402;
224/511–521, 533, 924; 248/317; 211/17;
414/462; D34/28, 35

DESCRIPTION

(56) **References Cited**

FIG. 1 is a perspective view of a motorcycle towing unit showing my new design;
FIG. 2 is a right side elevational view with the left side being a mirror image thereof;
FIG. 3 is a front elevational view thereof;
FIG. 4 is a rear elevational view thereof;
FIG. 5 is a top view thereof; and,
FIG. 6 is a bottom view thereof.

U.S. PATENT DOCUMENTS

3,776,572	12/1973	Bane .	
4,111,449	9/1978	Hancock .	
5,145,308	9/1992	Vaughn et al. .	
5,366,338	* 11/1994	Mortensen 414/462 X
5,560,628	10/1996	Horn .	
5,620,197	4/1997	Howes .	
5,647,719	* 7/1997	Bowlen 414/462

1 Claim, 3 Drawing Sheets

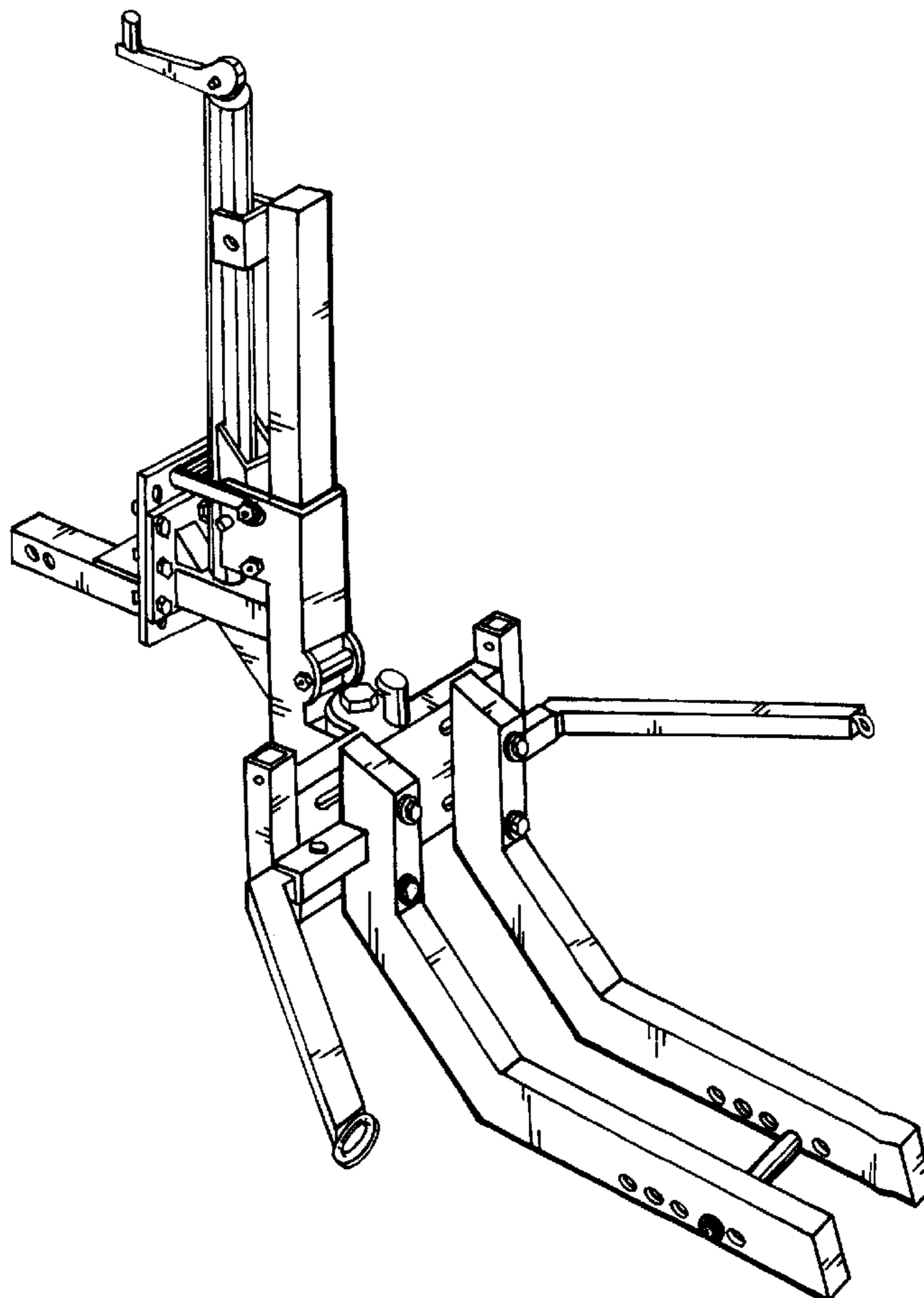

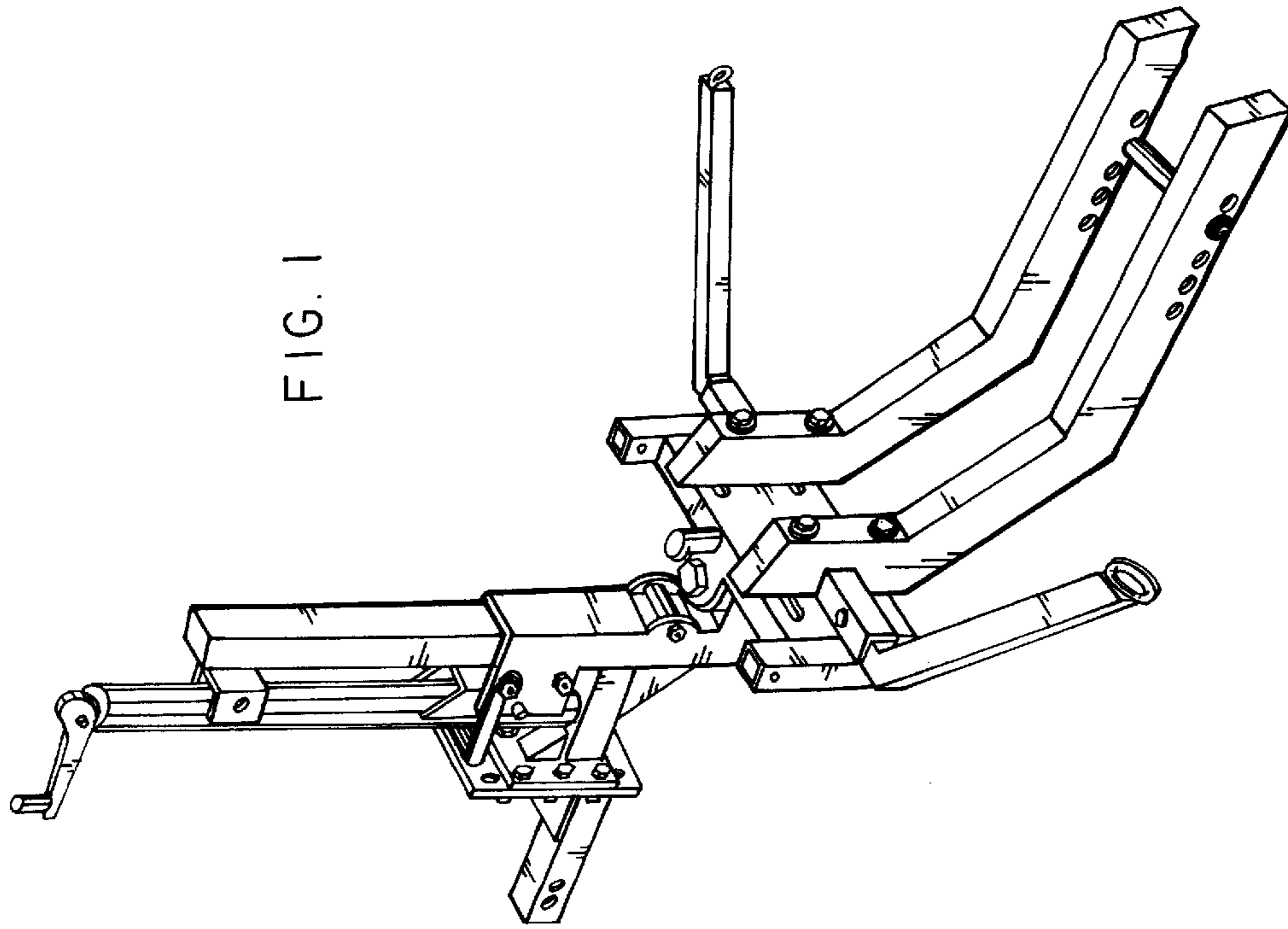

FIG. 1

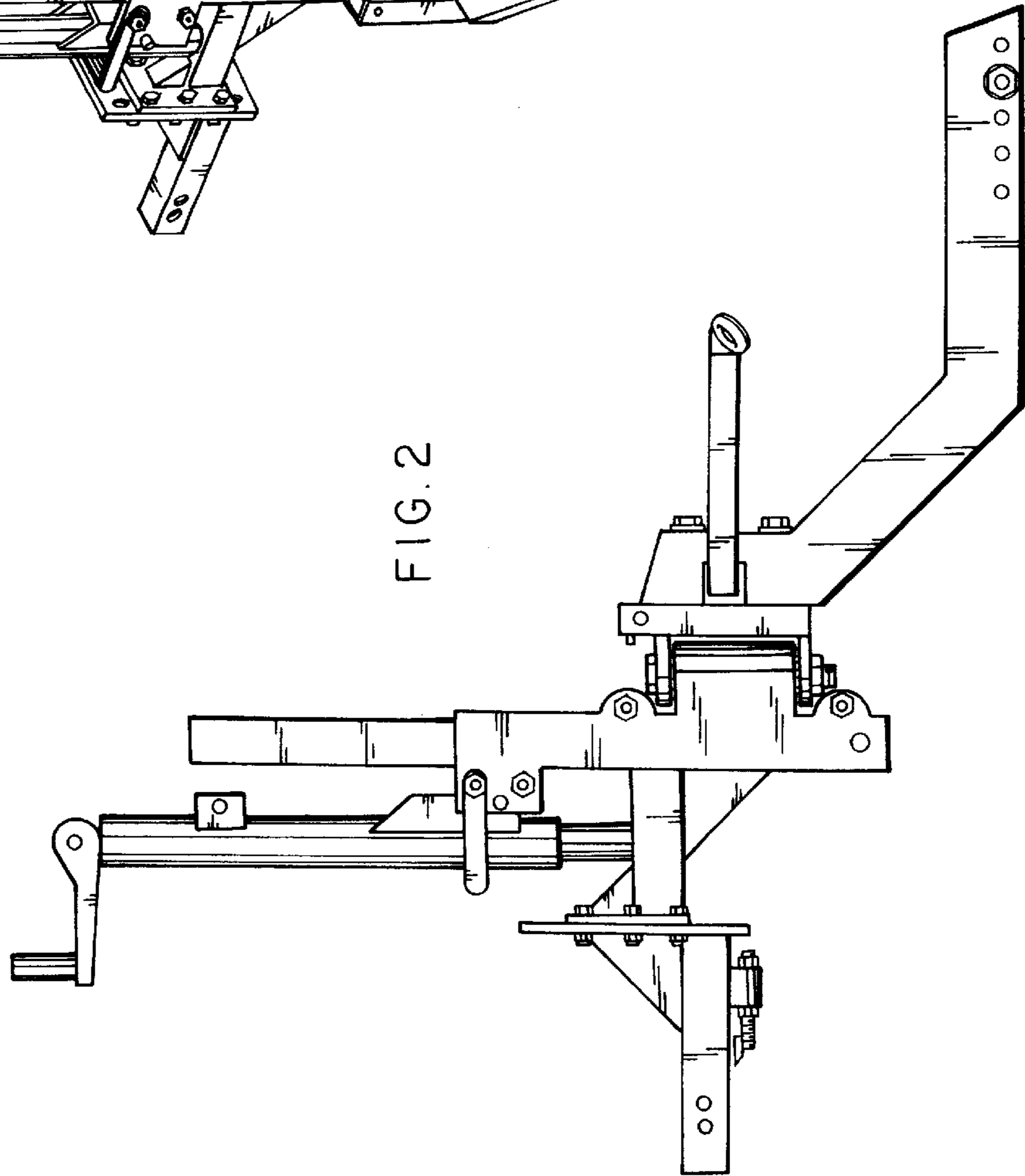

FIG. 2

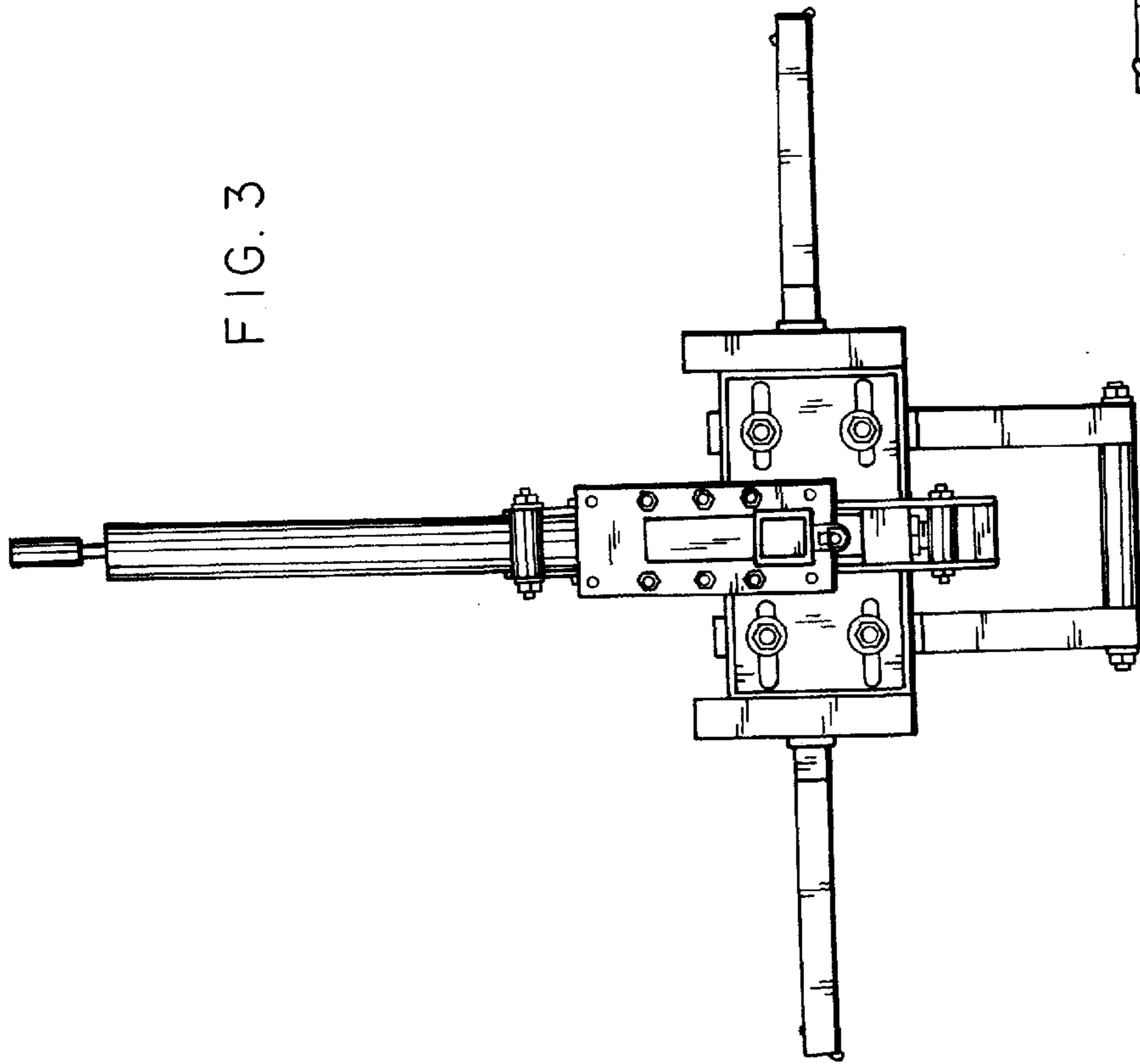

FIG. 3

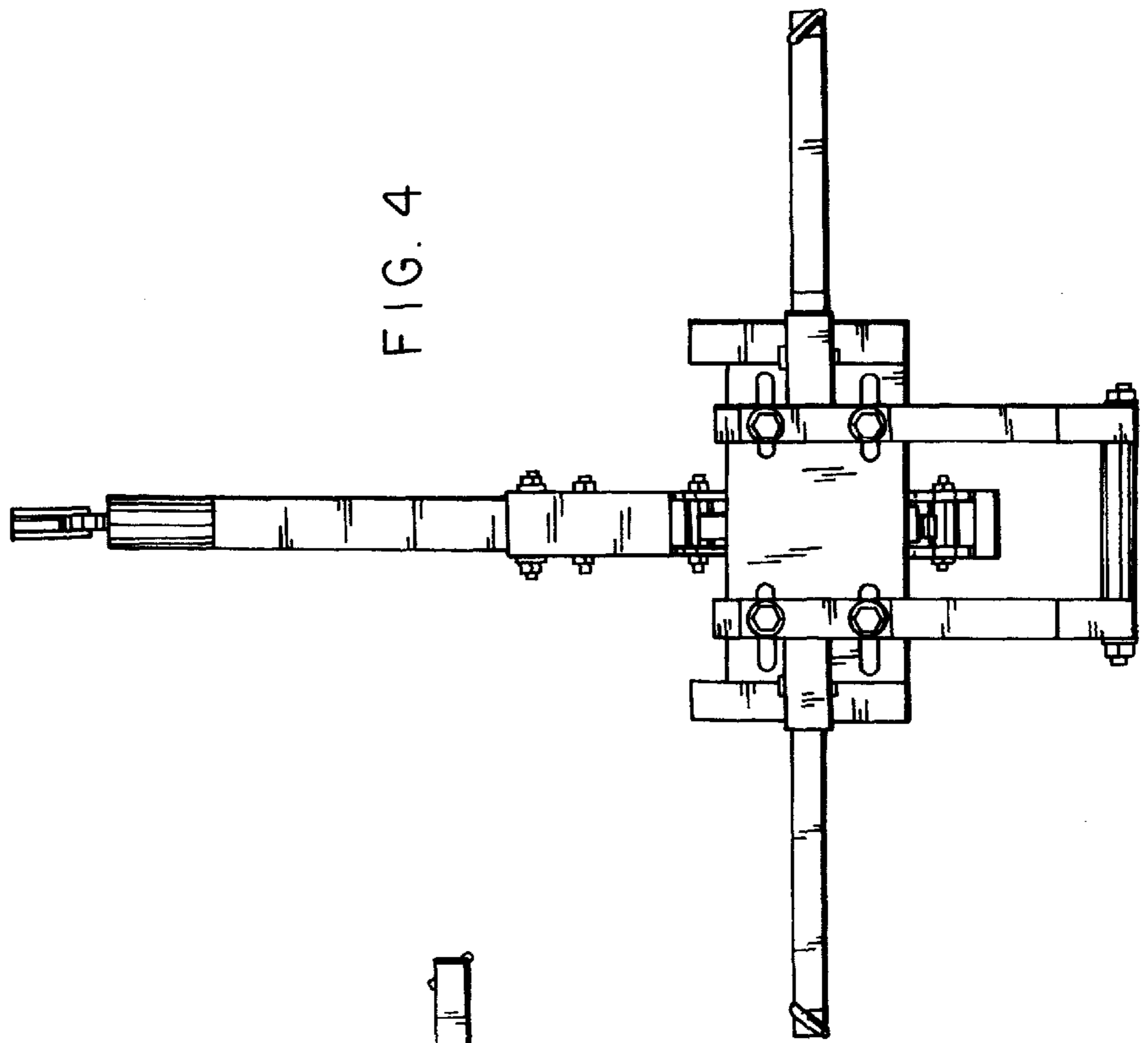

FIG. 4

