



US00D440931S

(12) **United States Design Patent**
Knight, III et al.

(10) **Patent No.:** **US D440,931 S**

(45) **Date of Patent:** **** Apr. 24, 2001**

(54) **AUXILIARY FOOT PAD FOR VEHICLE**

(76) Inventors: **E. Keith Knight, III**, 41 Becky Blvd., Russellville, AR (US) 72802; **Sean Christopher Knight**, 856 Quail Ridge Rd., Dover, AR (US) 72837

(**) Term: **14 Years**

(21) Appl. No.: **29/130,277**

(22) Filed: **Sep. 29, 2000**

(51) **LOC (7) Cl.** **12-16**

(52) **U.S. Cl.** **D12/203**

(58) **Field of Search** D12/203, 400, D12/202; 280/163, 164.1, 166; 224/42.13, 42.21-42.23, 491; 283/14; 182/17, 92, 116, 166; D25/62, 63, 69

(56) **References Cited**

U.S. PATENT DOCUMENTS

- D. 24,742 * 10/1895 Hummel D12/203
- D. 65,008 * 6/1924 Page D12/203
- D. 239,378 * 3/1976 Stecker, Sr. D12/203
- D. 292,388 * 10/1987 Weiler D12/203
- D. 293,667 * 1/1988 Weiler D12/203
- D. 296,321 * 6/1988 Hayes D12/203
- D. 296,431 * 6/1988 Yont D12/203
- D. 316,394 * 4/1991 Carr D12/203
- D. 324,019 * 2/1992 Bailey D12/203
- D. 340,904 * 11/1993 Bevier D12/203

- D. 364,597 * 11/1995 Branch D12/203
- D. 370,452 * 6/1996 Beasley D12/203
- D. 376,784 * 12/1996 Miller D12/203
- D. 394,628 * 5/1998 Wentzel D12/203
- 2,991,118 * 7/1961 Sleger D12/203 X

* cited by examiner

Primary Examiner—Stacia Cadmus

(74) *Attorney, Agent, or Firm*—Head, Johnson & Kachigian; Trent C. Keisling

(57) **CLAIM**

The ornamental design for an auxiliary foot pad for vehicle, as shown and described.

DESCRIPTION

FIG. 1 is a perspective view of an auxiliary foot pad for vehicle showing my new design taken generally from the front;

FIG. 2 is a perspective view thereof taken generally from the opposite of FIG. 1;

FIG. 3 is a front elevational view thereof;

FIG. 4 is a rear elevational view thereof;

FIG. 5 is a side elevational view thereof, taken generally from the left of FIG. 3;

FIG. 6 is a side elevational view thereof, taken generally from the opposite side of FIG. 5;

FIG. 7 is a top plan view thereof; and,

FIG. 8 is a bottom plan view thereof.

1 Claim, 3 Drawing Sheets

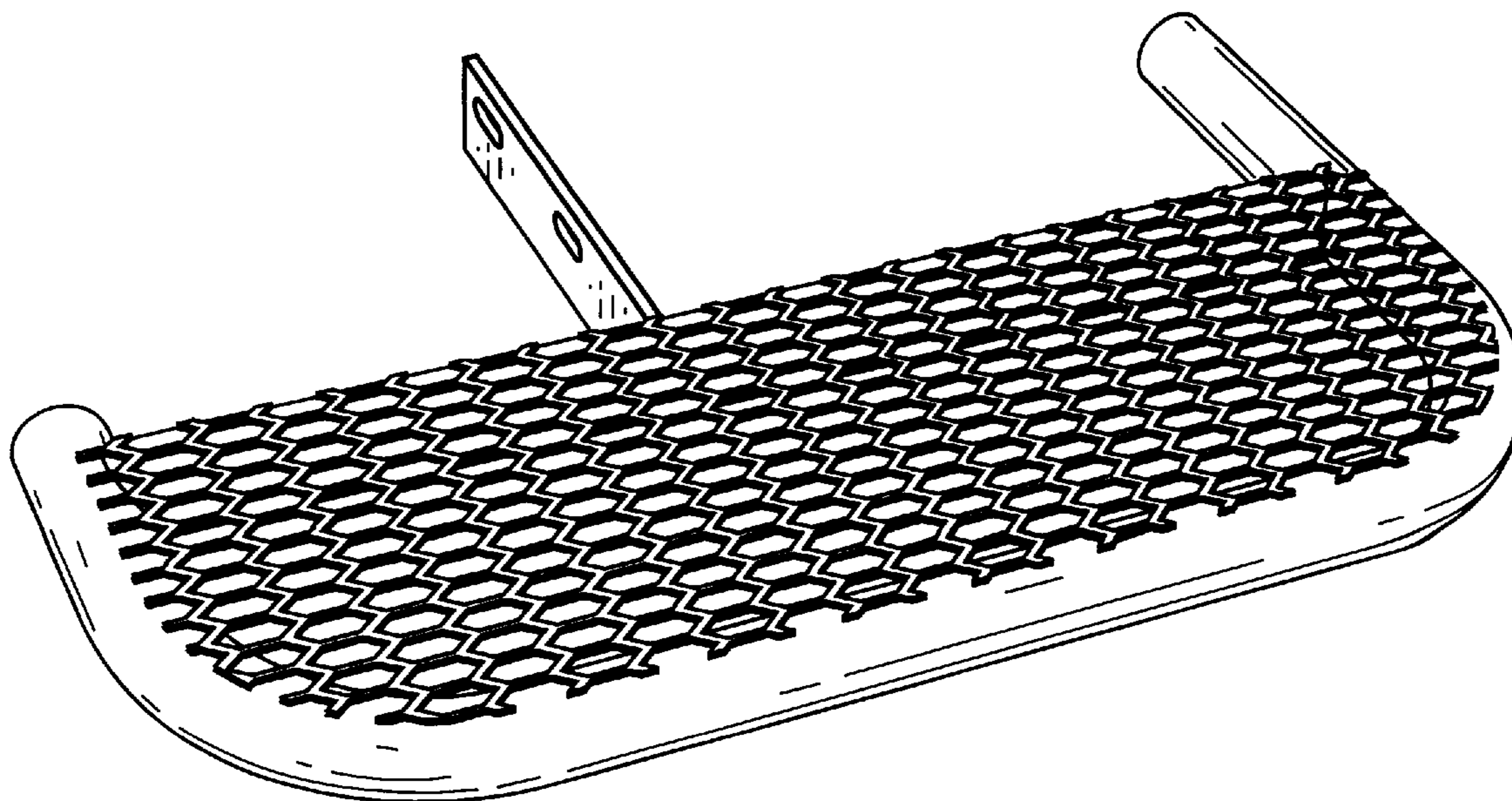

FIG. 1

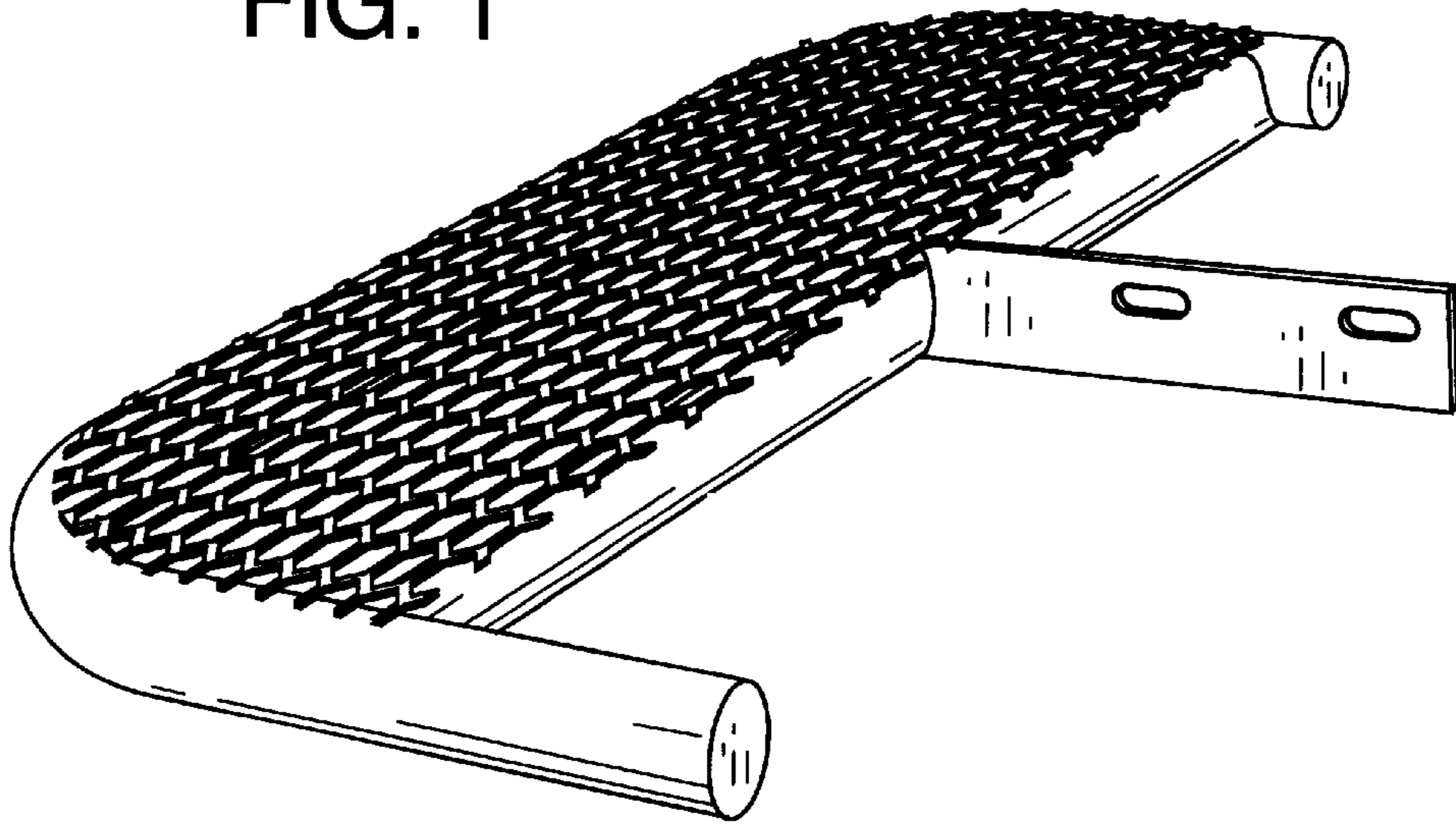

FIG. 2

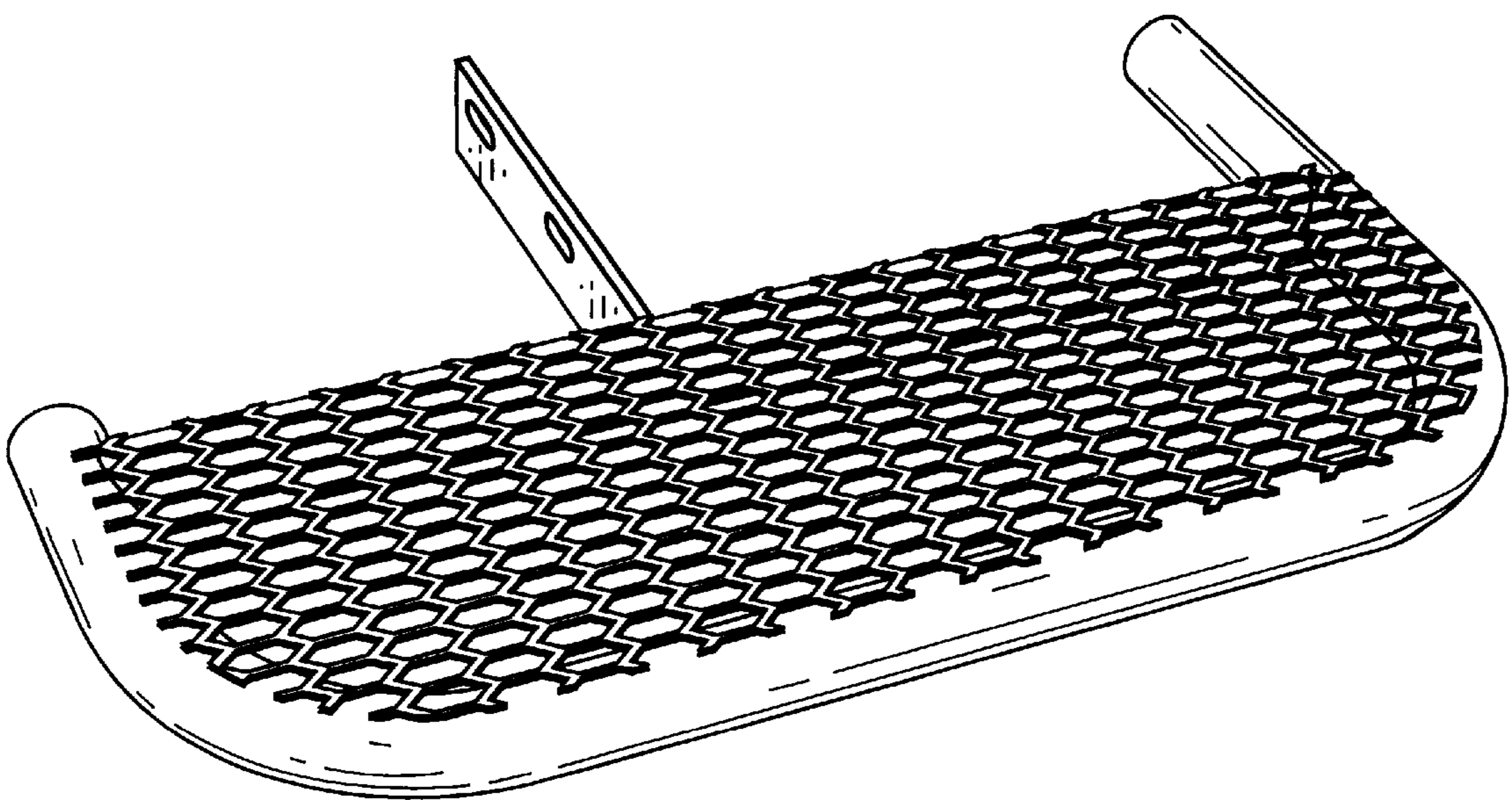

FIG. 3



FIG. 4



FIG. 7

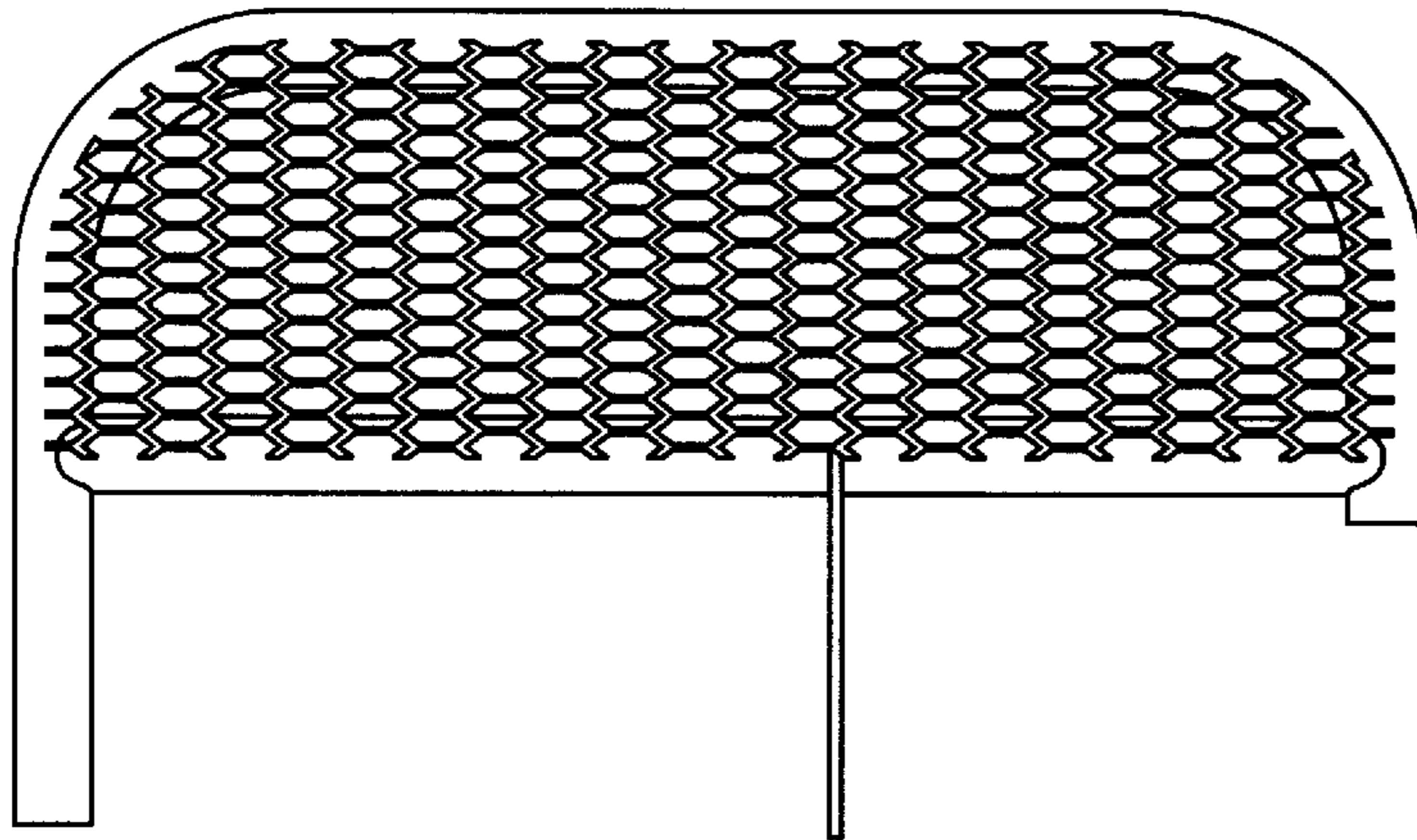

FIG. 5

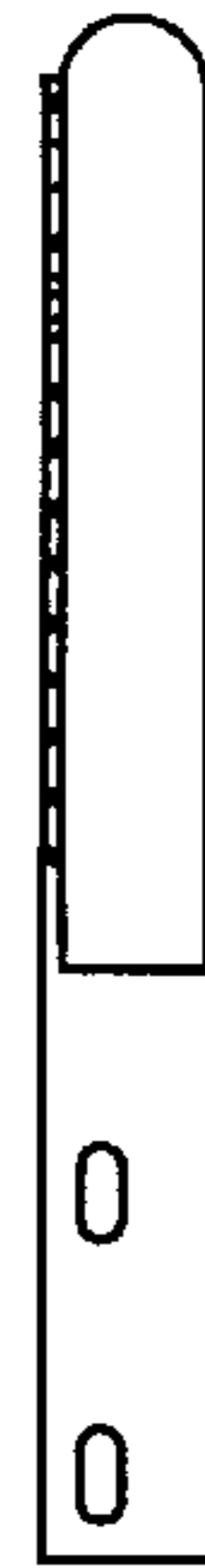

FIG. 6

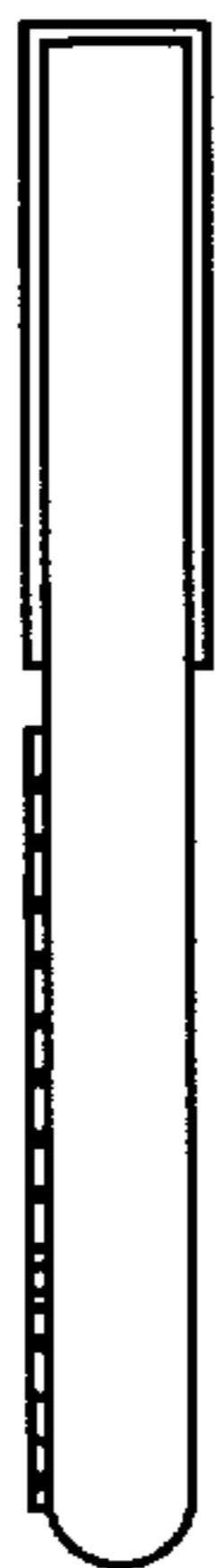

FIG. 8

