



US00D440926S

(12) **United States Design Patent**
Pfeiffer

(10) **Patent No.:** **US D440,926 S**

(45) **Date of Patent:** **** Apr. 24, 2001**

(54) **INSTRUMENT PANEL AND DASHBOARD FOR A VEHICLE**

(75) Inventor: **Peter Pfeiffer**, Boeblingen (DE)

(73) Assignee: **DaimlerChrysler AG**, Stuttgart (DE)

(**) Term: **14 Years**

(21) Appl. No.: **29/126,334**

(22) Filed: **Jul. 10, 2000**

(30) **Foreign Application Priority Data**

Jan. 10, 2000 (DE) 400 00 059

(51) **LOC (7) Cl.** **12-16**

(52) **U.S. Cl.** **D12/192**

(58) **Field of Search** D12/192, 400,
D12/415; 180/90; 280/750, 752; 296/70,
190-191

(56) **References Cited**

U.S. PATENT DOCUMENTS

- D. 339,786 * 9/1993 Allendorph et al. D12/192
- D. 369,999 * 5/1996 Sacco et al. D12/192
- D. 372,010 * 7/1996 Pfeiffer et al. D12/192
- D. 389,798 * 1/1998 Ma et al. D12/192

- D. 403,641 * 1/1999 Sacco et al. D12/192
- D. 405,408 * 2/1999 Yoshida et al. D12/192
- D. 419,936 * 2/2000 Sacco et al. D12/192
- D. 424,002 * 5/2000 Leschke et al. D12/192
- D. 431,220 * 9/2000 Wyszgrod et al. D12/192
- D. 433,362 * 11/2000 Wyszgrod et al. D12/192

* cited by examiner

Primary Examiner—Stacia Cadmus

(74) *Attorney, Agent, or Firm*—Evenson, McKeown, Edwards & Lenahan, P.L.L.C.

(57) **CLAIM**

The ornamental design for an instrument panel and dashboard for a vehicle, as shown and described.

DESCRIPTION

FIG. 1 is a right, perspective view of a instrument panel and dashboard for a vehicle according to my novel design; FIG. 2 is a left, perspective view of the instrument panel and dashboard for a vehicle according to my novel design; and, FIG. 3 is a front view of the instrument panel and dashboard for a vehicle according to my novel design. The dash lines included depict environment and are not part of the claimed design.

1 Claim, 3 Drawing Sheets

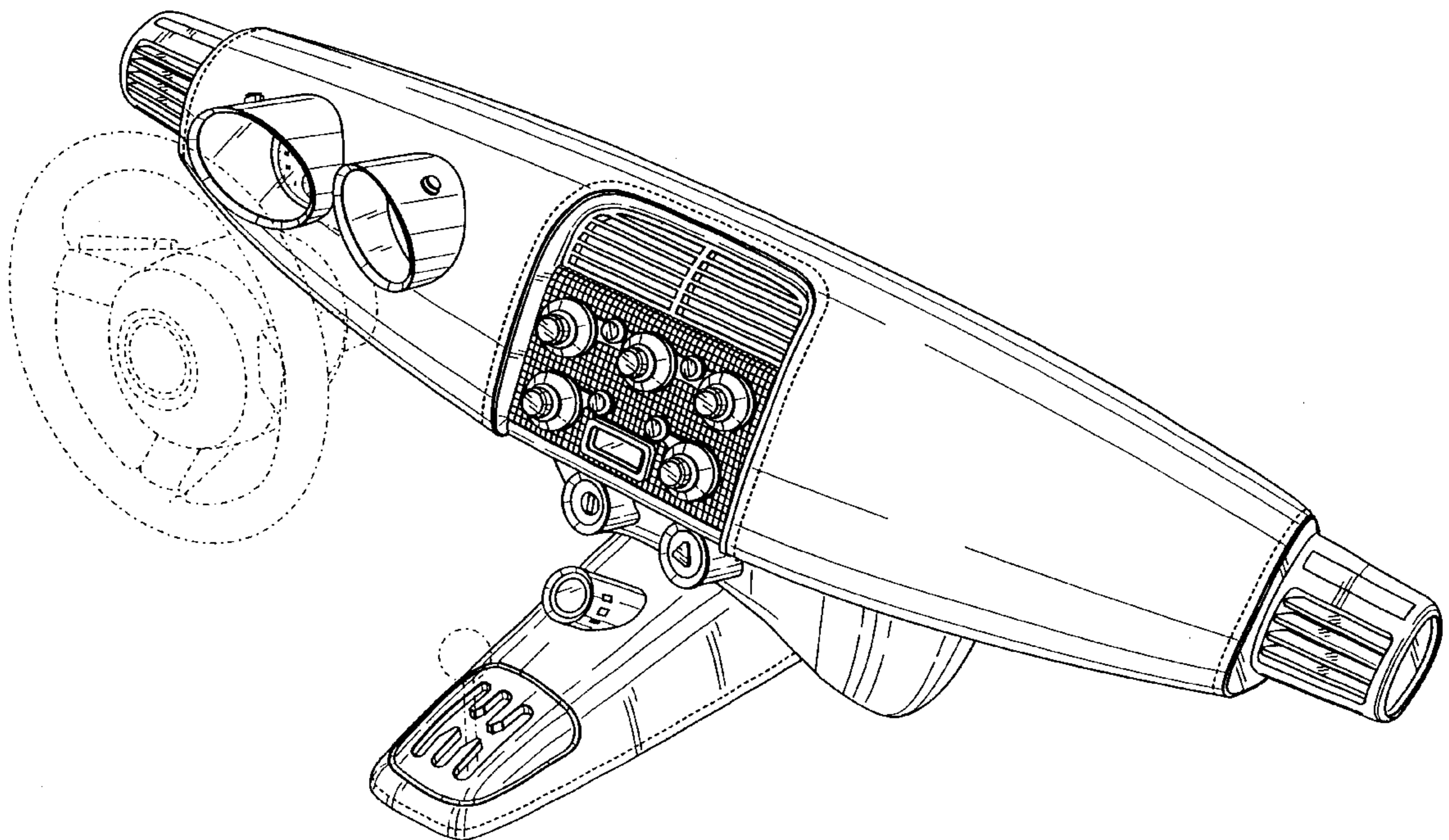

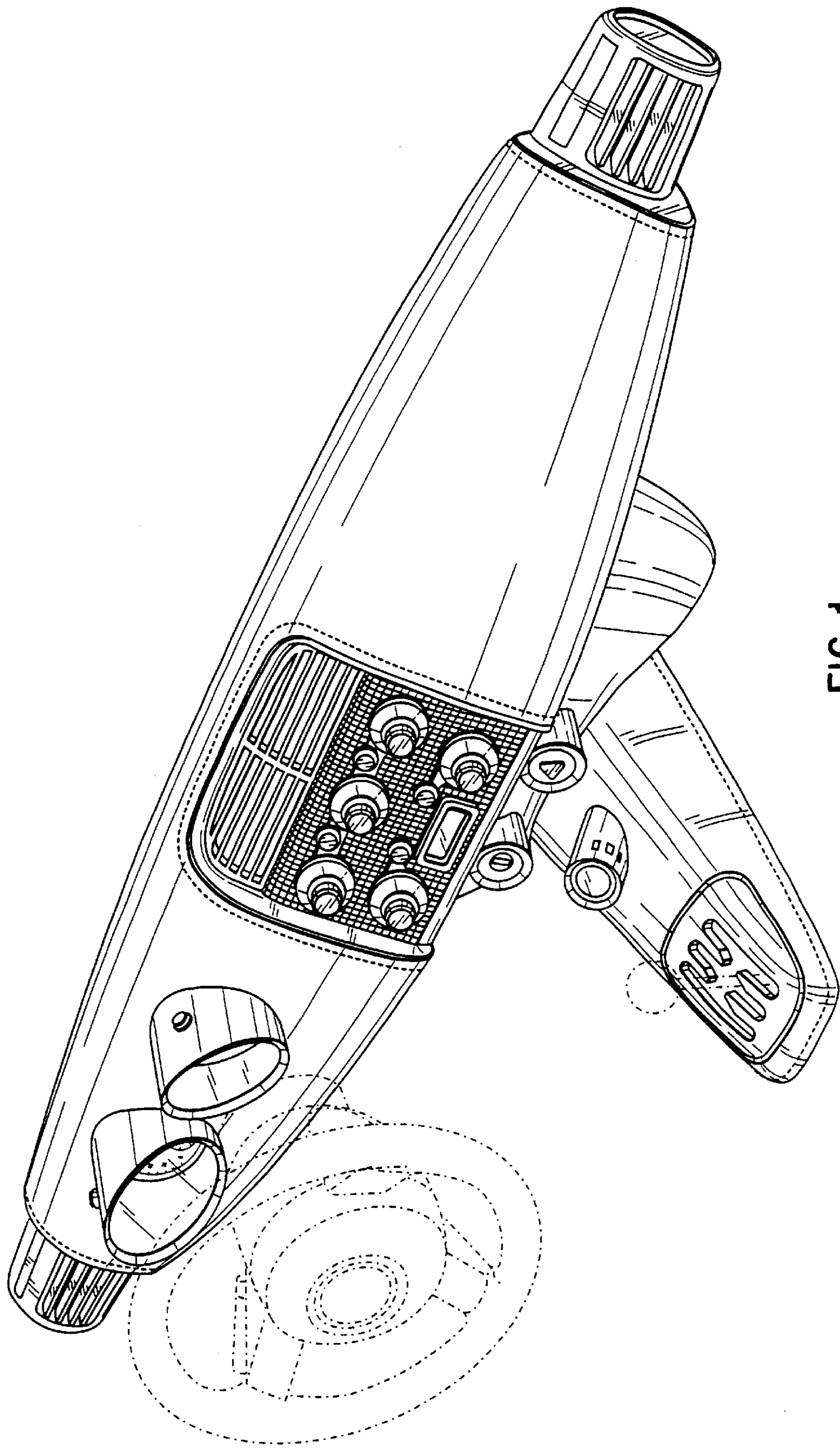

FIG. 1

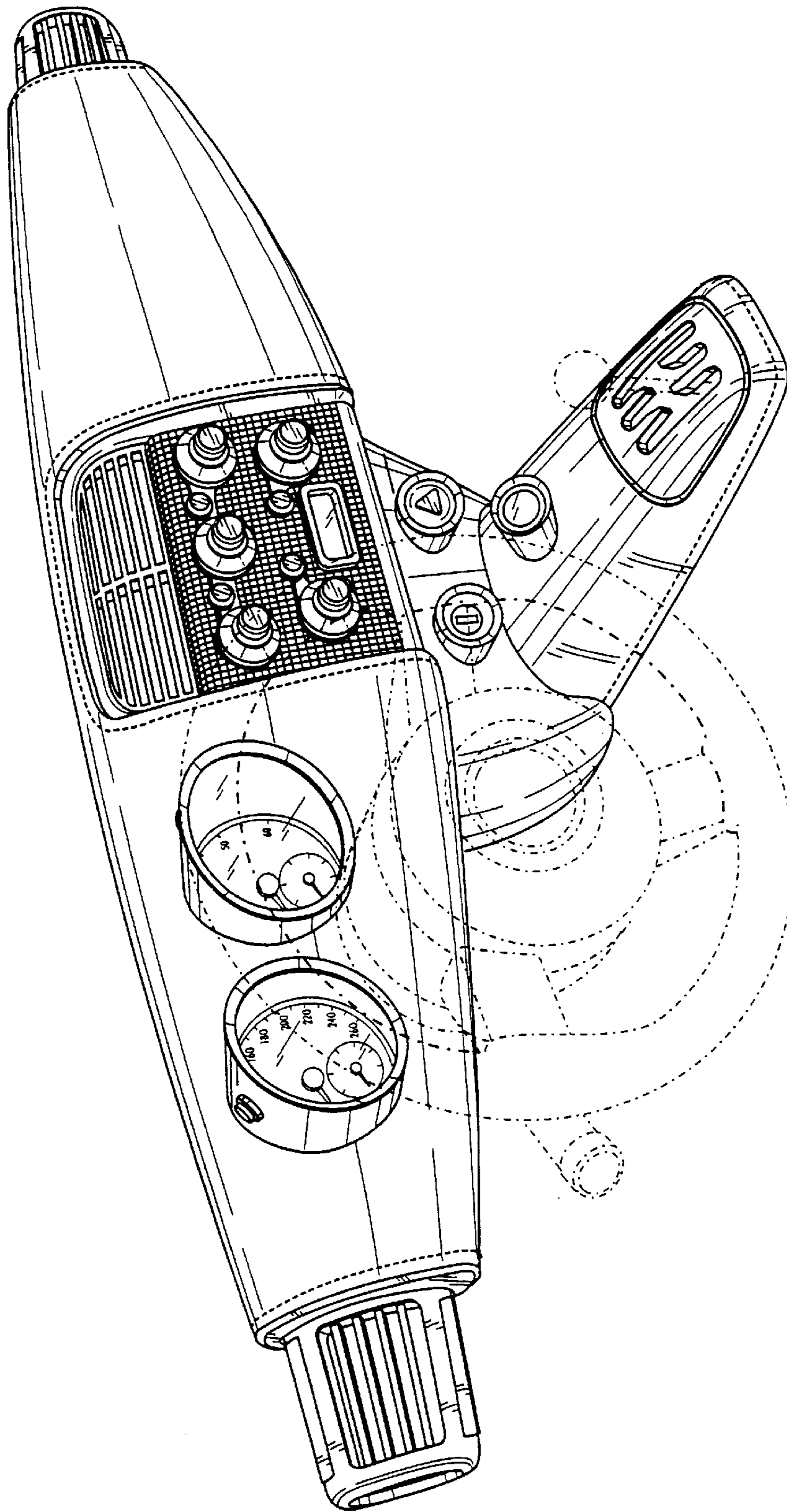

FIG. 2

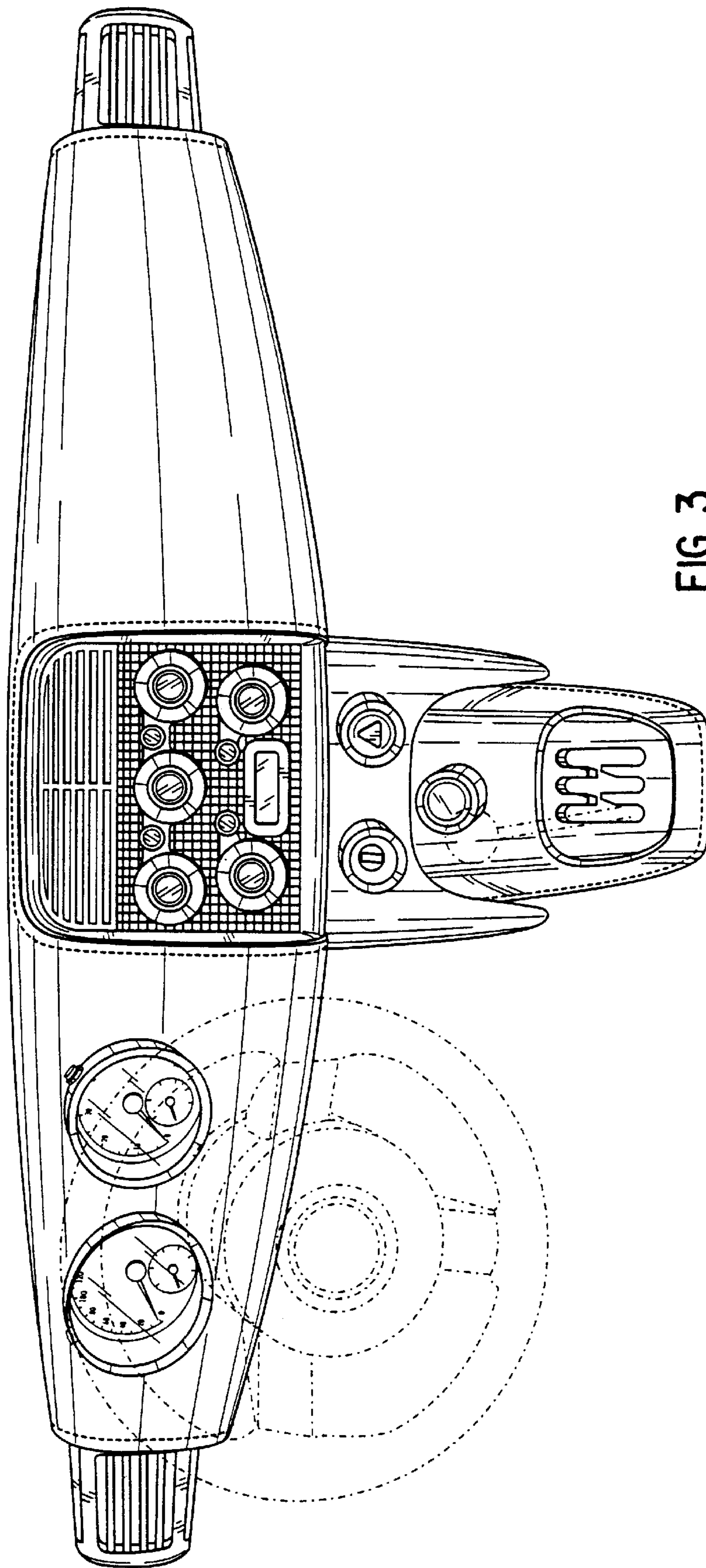

FIG. 3