



US00D440861S

(12) **United States Design Patent**
Thompson

(10) **Patent No.:** **US D440,861 S**

(45) **Date of Patent:** **** Apr. 24, 2001**

(54) **QUAD-HOOK FOR A STEERING WHEEL LOCK**

5,921,120 * 7/1999 Wu 70/209

FOREIGN PATENT DOCUMENTS

(75) **Inventor:** **Roy Alden Thompson**, Mattapan, MA (US)

10-331500 12/1998 (JP) .

* cited by examiner

(73) **Assignee:** **Master Lock Company**, Milwaukee, WI (US)

Primary Examiner—Susan J. Lucas

Assistant Examiner—Jennifer Rivard

(**) **Term:** **14 Years**

(74) *Attorney, Agent, or Firm*—Pennie & Edmonds LLP

(21) **Appl. No.:** **29/118,672**

(57) **CLAIM**

(22) **Filed:** **Feb. 15, 2000**

The ornamental design for a quad-hook for a steering wheel lock, as shown and described.

(51) **LOC (7) Cl.** **08-07**

DESCRIPTION

(52) **U.S. Cl.** **D8/343**

(58) **Field of Search** D8/330, 331, 343, D8/363, 370; 70/18, 19, 209, 211, 212, 225, 226, 227, 237, 238, 431

FIG. 1 is a top perspective view of the quad-hook for a steering wheel lock of the present invention; FIG. 2 is a bottom perspective view of the quad-hook for a steering wheel lock of the present invention; FIG. 3 is a top view thereof; FIG. 4 is a bottom view thereof; FIG. 5 is a left end view thereof; FIG. 6 is a right end view thereof; FIG. 7 is a side view thereof; and, FIG. 8 is a side view thereof, opposite that of FIG. 7.

(56) **References Cited**

U.S. PATENT DOCUMENTS

D. 324,163	*	2/1992	Lo	D8/331
D. 357,621		4/1995	Yang	D8/343
D. 368,421		4/1996	Jensen, Sr.	D8/331
D. 369,951		5/1996	Crittenden	D8/331
D. 370,616		6/1996	Fard	D8/331
3,690,131		9/1972	Davis	70/203
5,197,308		3/1993	Pazik	70/209
5,406,813	*	4/1995	Lo	70/209
5,435,158	*	7/1995	Ta-Yung	70/209
5,778,709		7/1998	Hsu	70/209

The portions shown in phantom lines are not part of the claimed invention, but are included to show environment. The phantom lines illustrate a feature such as a steering wheel lock to which the quad-hook can be attached.

1 Claim, 7 Drawing Sheets

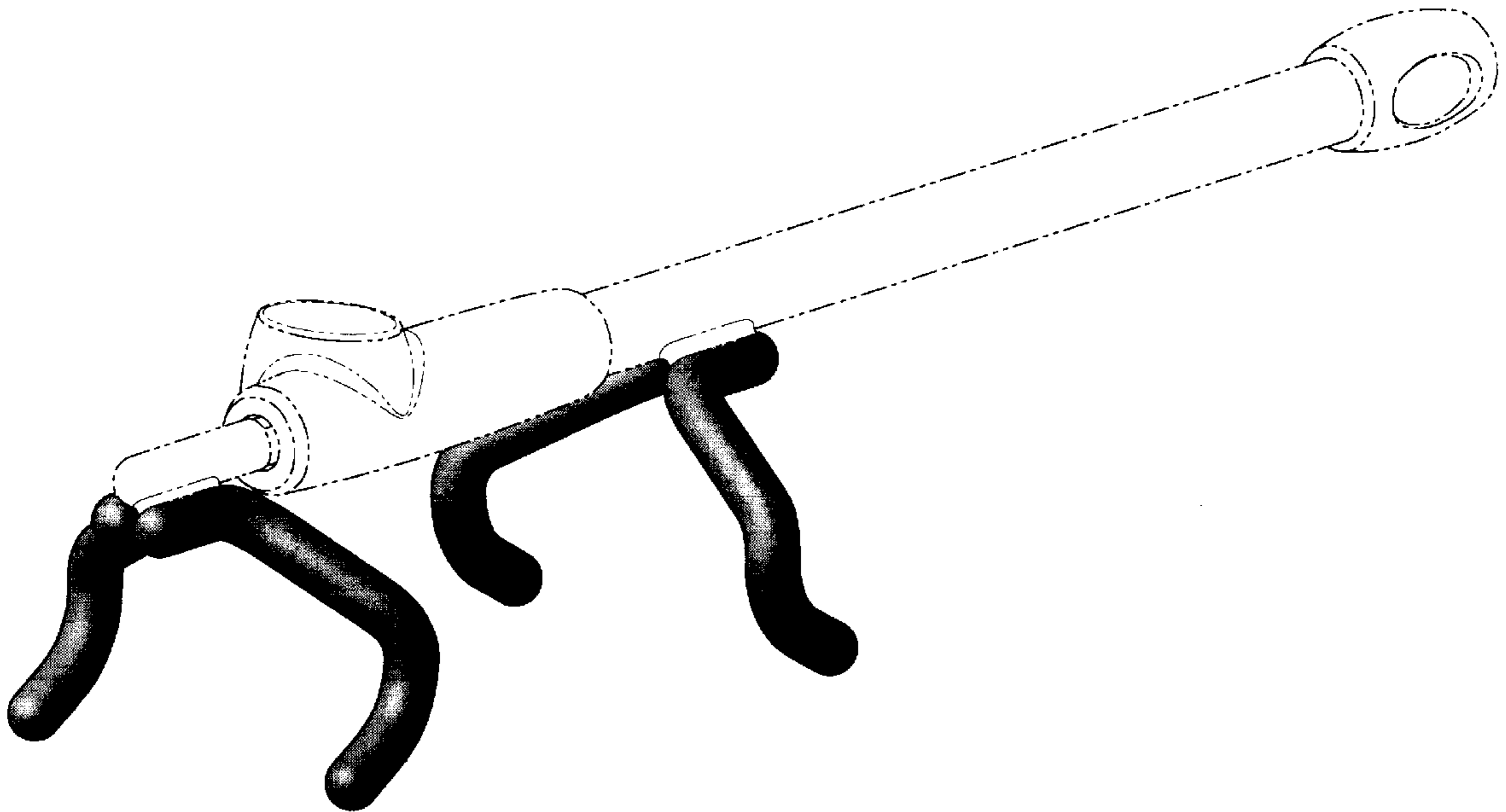

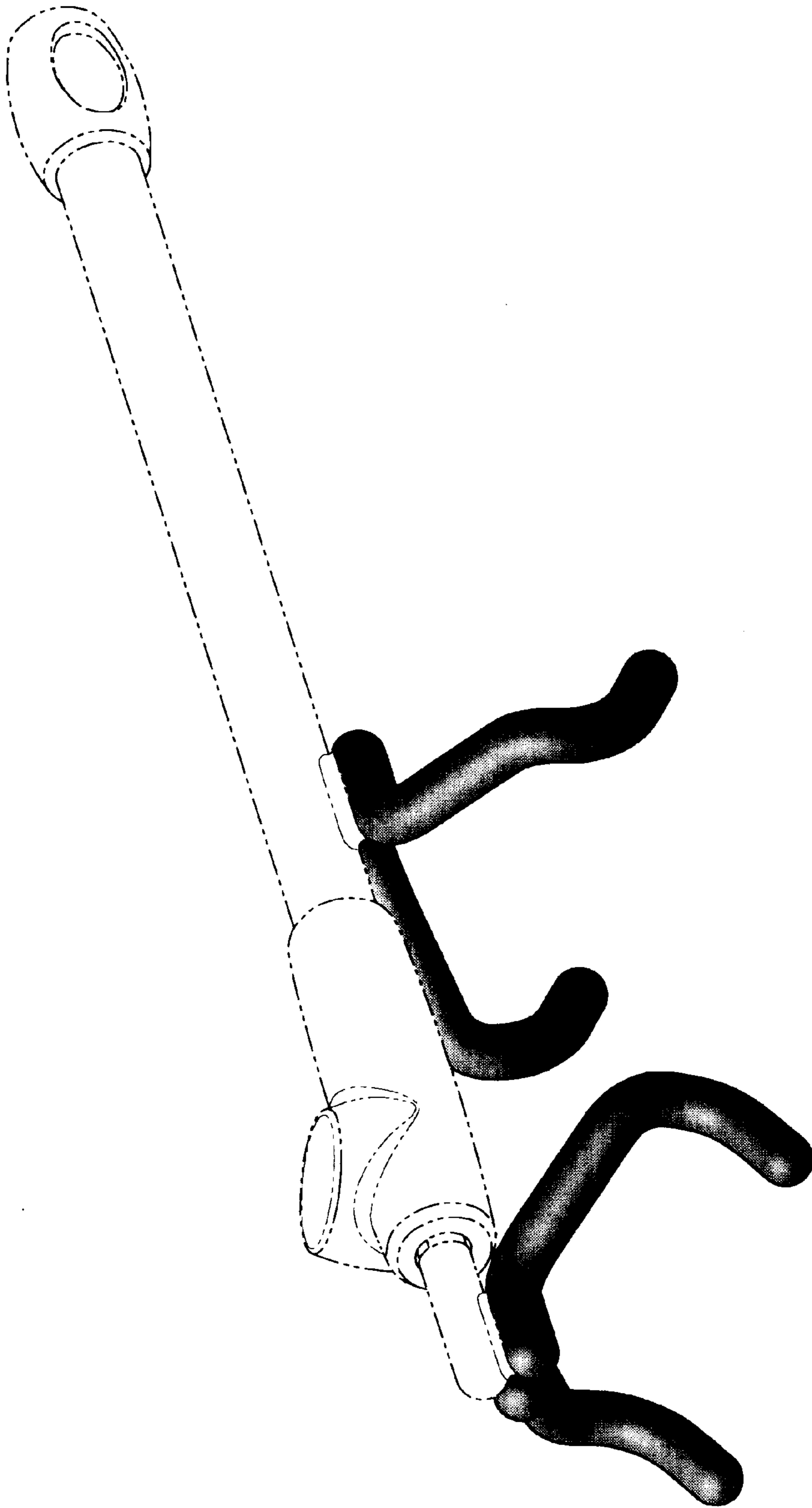

FIG. 1

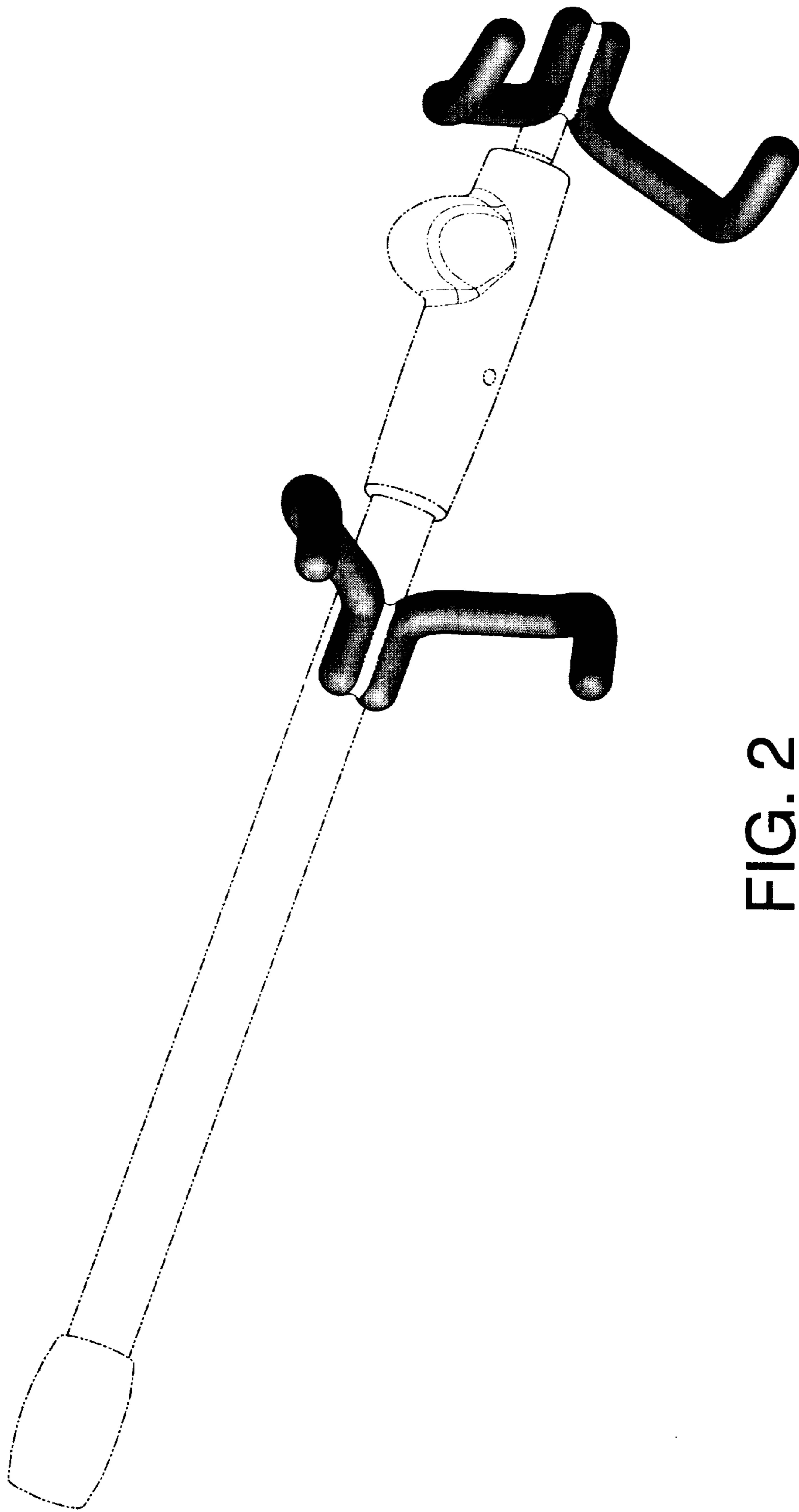

FIG. 2

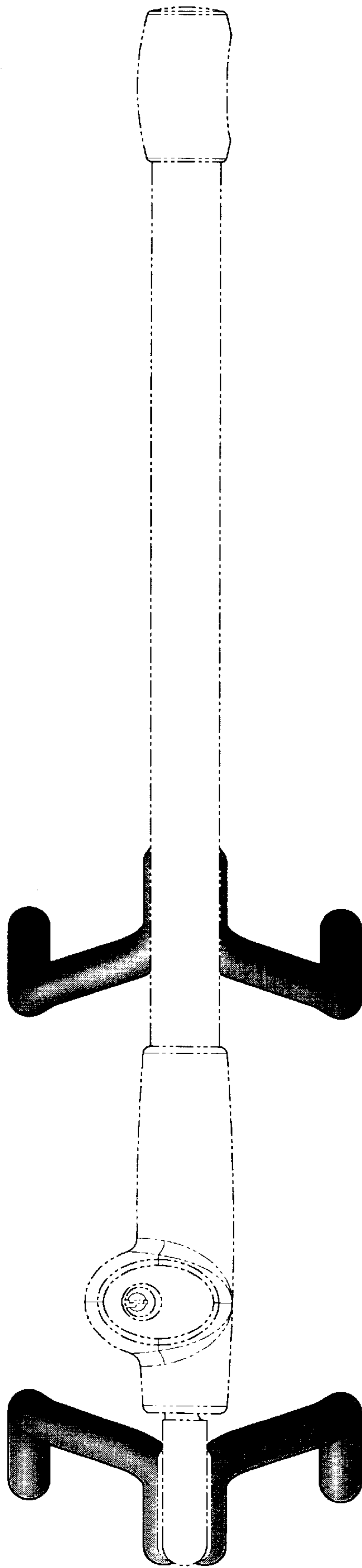

FIG. 3

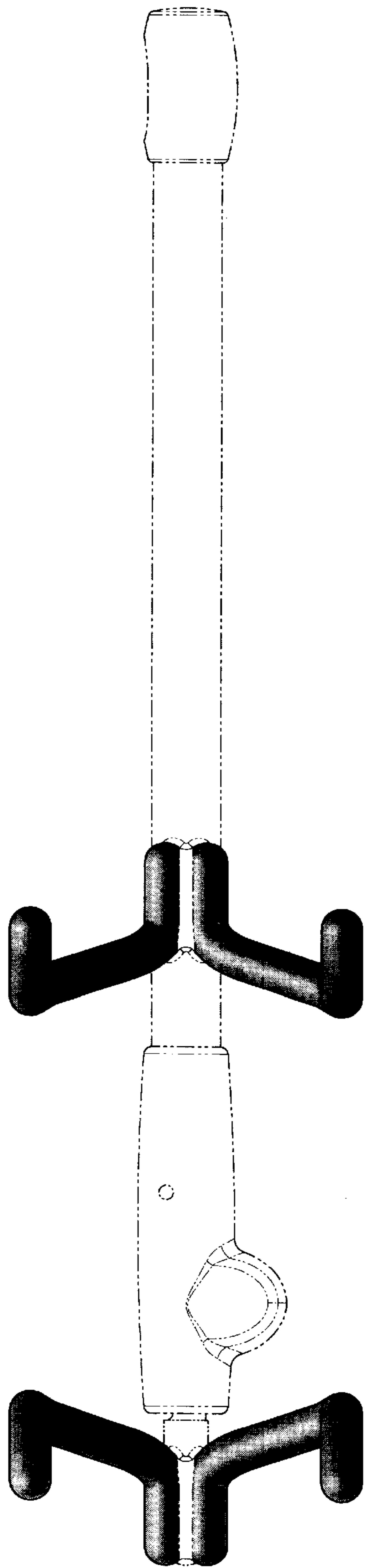

FIG. 4

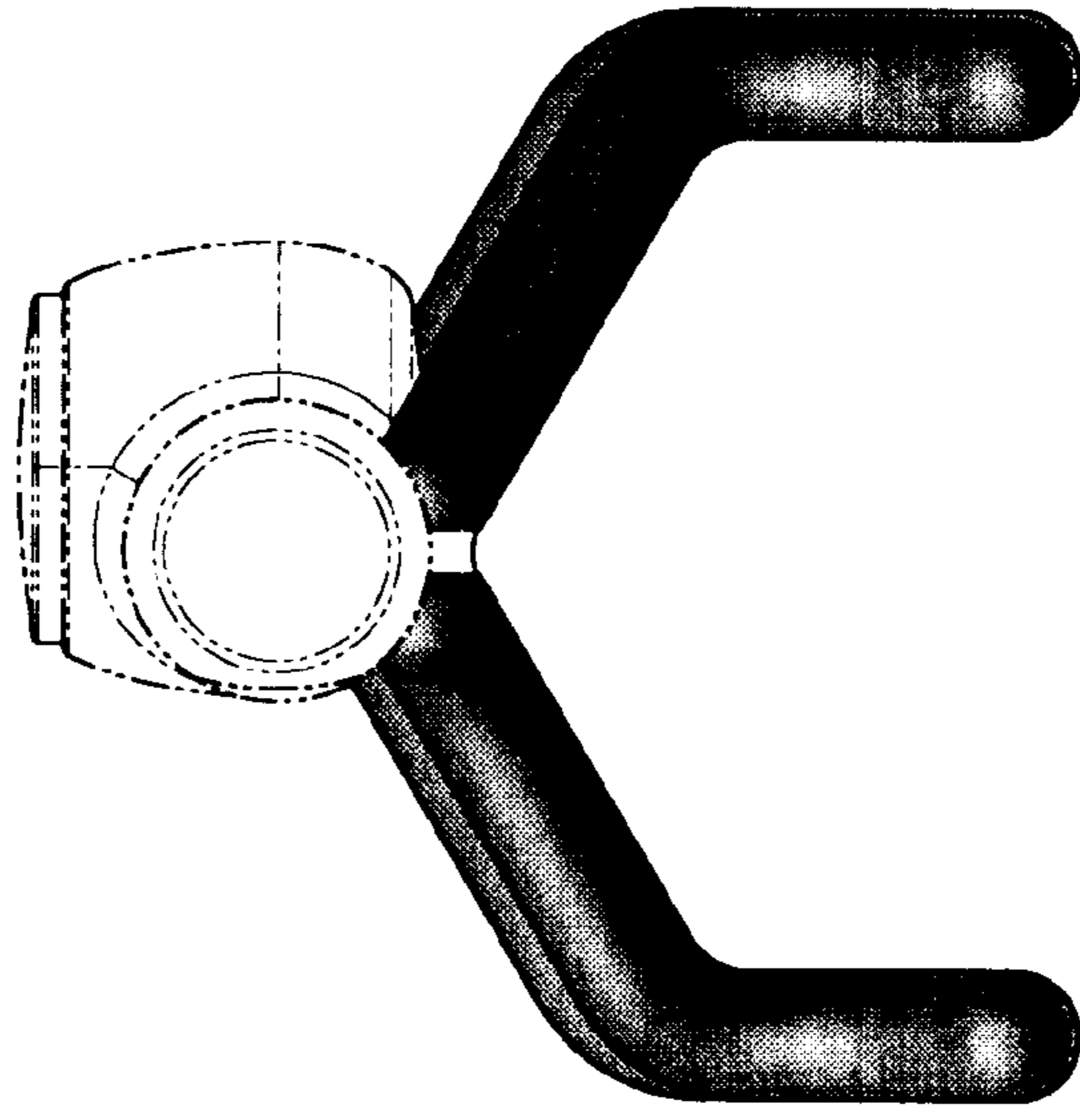

FIG. 5

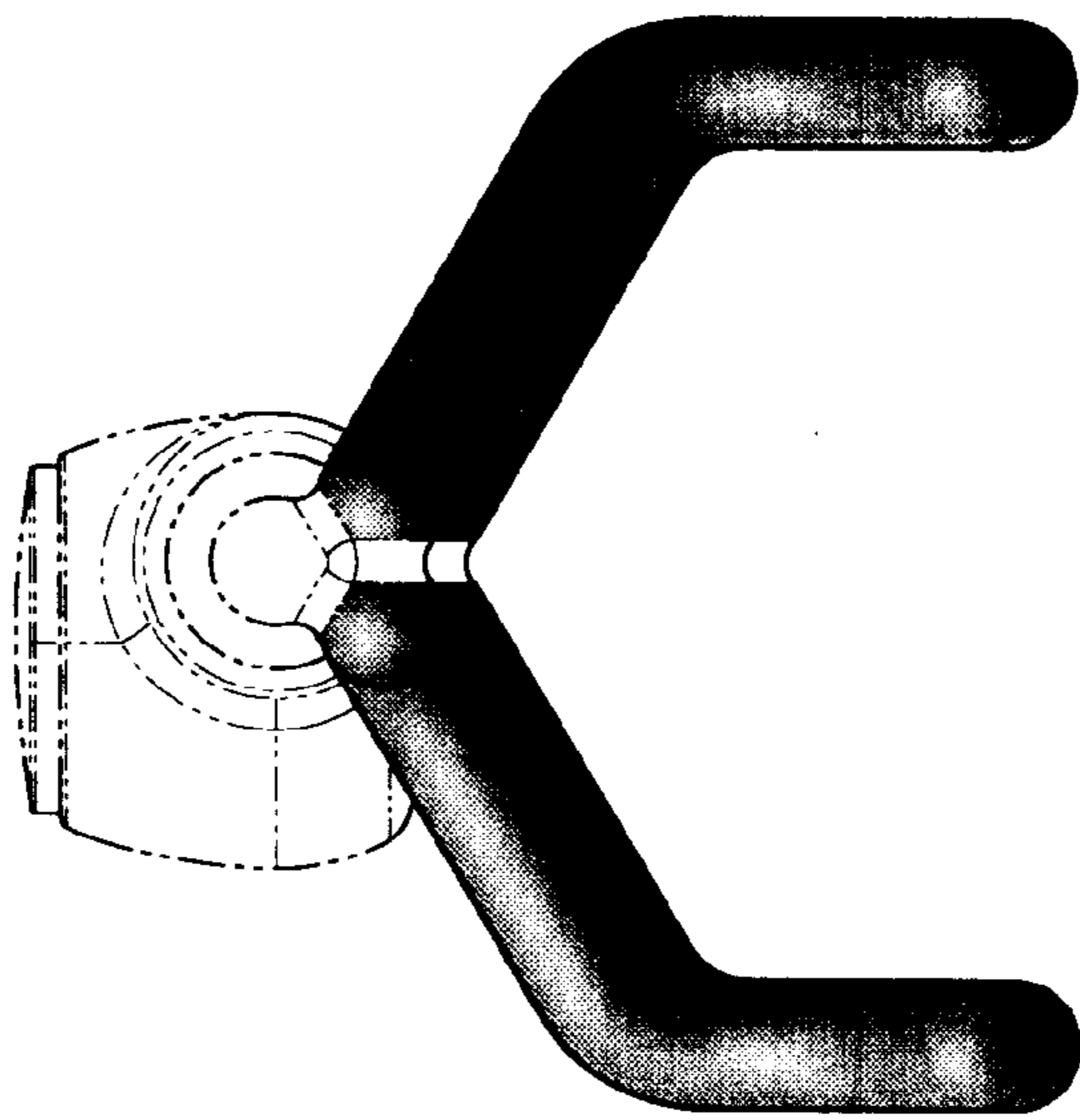

FIG. 6

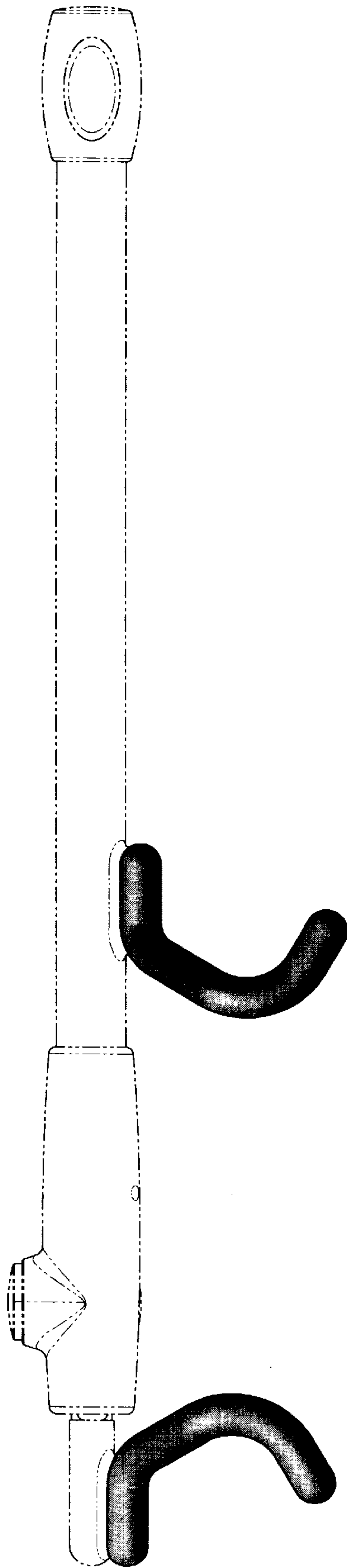

FIG. 7

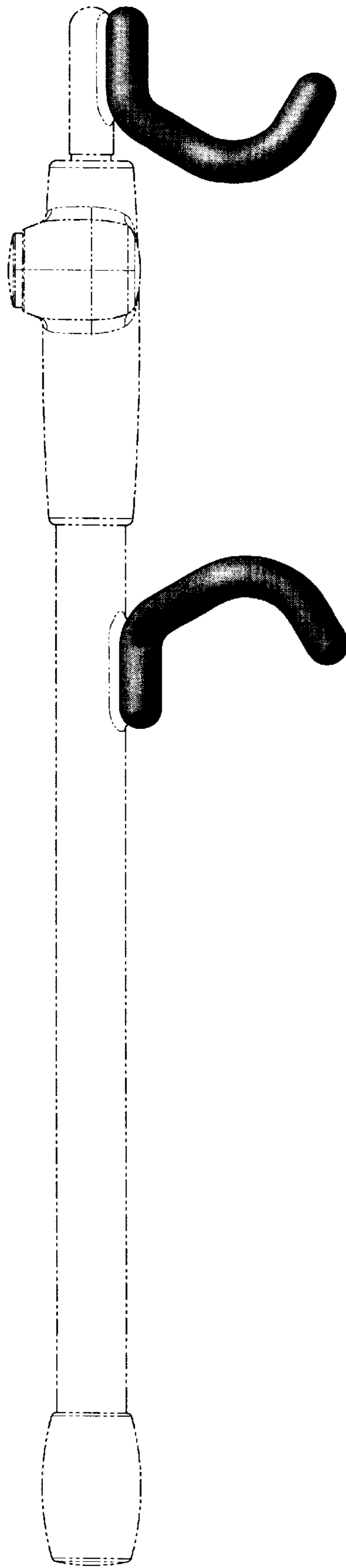

FIG. 8