



US00D440461S

(12) **United States Design Patent**  
**Mak**

(10) **Patent No.:** **US D440,461 S**

(45) **Date of Patent:** **\*\* \*Apr. 17, 2001**

(54) **PORTABLE COOKING GRILL**

(76) Inventor: **Tai Mak**, 101 E. State St., Jacksonville, FL (US) 32202

(\* ) Notice: This patent is subject to a terminal disclaimer.

(\*\*) Term: **14 Years**

(21) Appl. No.: **29/119,319**

(22) Filed: **Feb. 25, 2000**

(51) **LOC (7) Cl.** ..... **07-02**

(52) **U.S. Cl.** ..... **D7/332**

(58) **Field of Search** ..... D7/332-337, 402; D21/708-709, 712-714, 533, 548-549, 580; D11/157, 163; 126/25 R, 25 A, 25 AA, 29-30, 9 R, 39 R, 41 R; 99/419, 421 R; 446/268, 431, 465, 470; 473/351, 355-356, 365, 378-385

(56) **References Cited**

**U.S. PATENT DOCUMENTS**

- D. 237,094 \* 10/1975 Martin ..... D21/709
- D. 268,008 \* 2/1983 Witt, Jr. .... D9/307
- D. 314,882 \* 2/1991 Bethel, Jr. .... D7/334
- D. 349,008 \* 7/1994 Minor ..... D7/606
- D. 358,324 \* 5/1995 Mitchell ..... D9/307

- D. 383,980 \* 9/1997 Abfier et al. .... D9/502
- D. 396,599 \* 8/1998 Smith, Jr. .... D7/332
- D. 401,605 \* 11/1998 Shirley ..... D16/227
- D. 418,004 \* 12/1999 Taylor, Jr. .... D7/332
- D. 418,359 \* 1/2000 Taylor, Jr. .... D7/332
- D. 421,035 \* 2/2000 Shirley et al. .... D16/227
- D. 421,200 \* 2/2000 Taylor, Jr. .... D7/332
- 3,624,939 \* 12/1971 Gossard .

\* cited by examiner

*Primary Examiner*—Ruth McInroy

(74) *Attorney, Agent, or Firm*—Thomas C. Saitta

(57) **CLAIM**

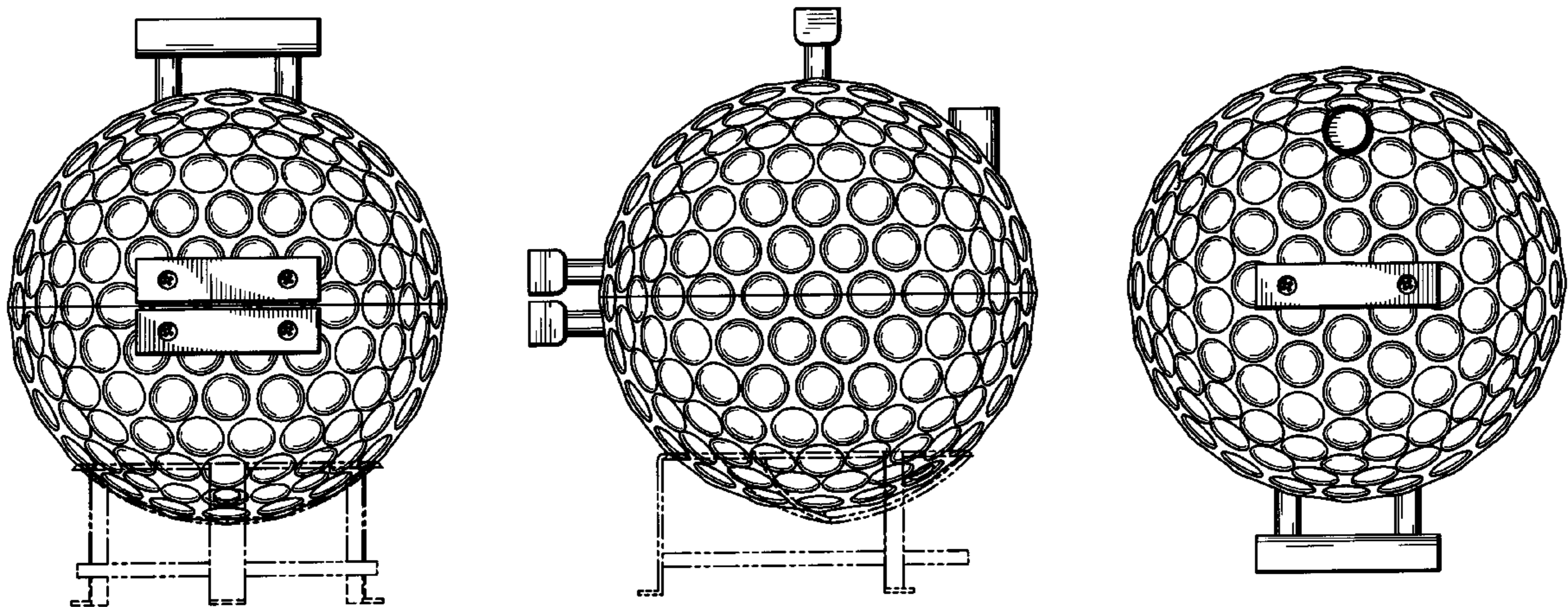
The ornamental design for a portable cooking grill, as shown and described.

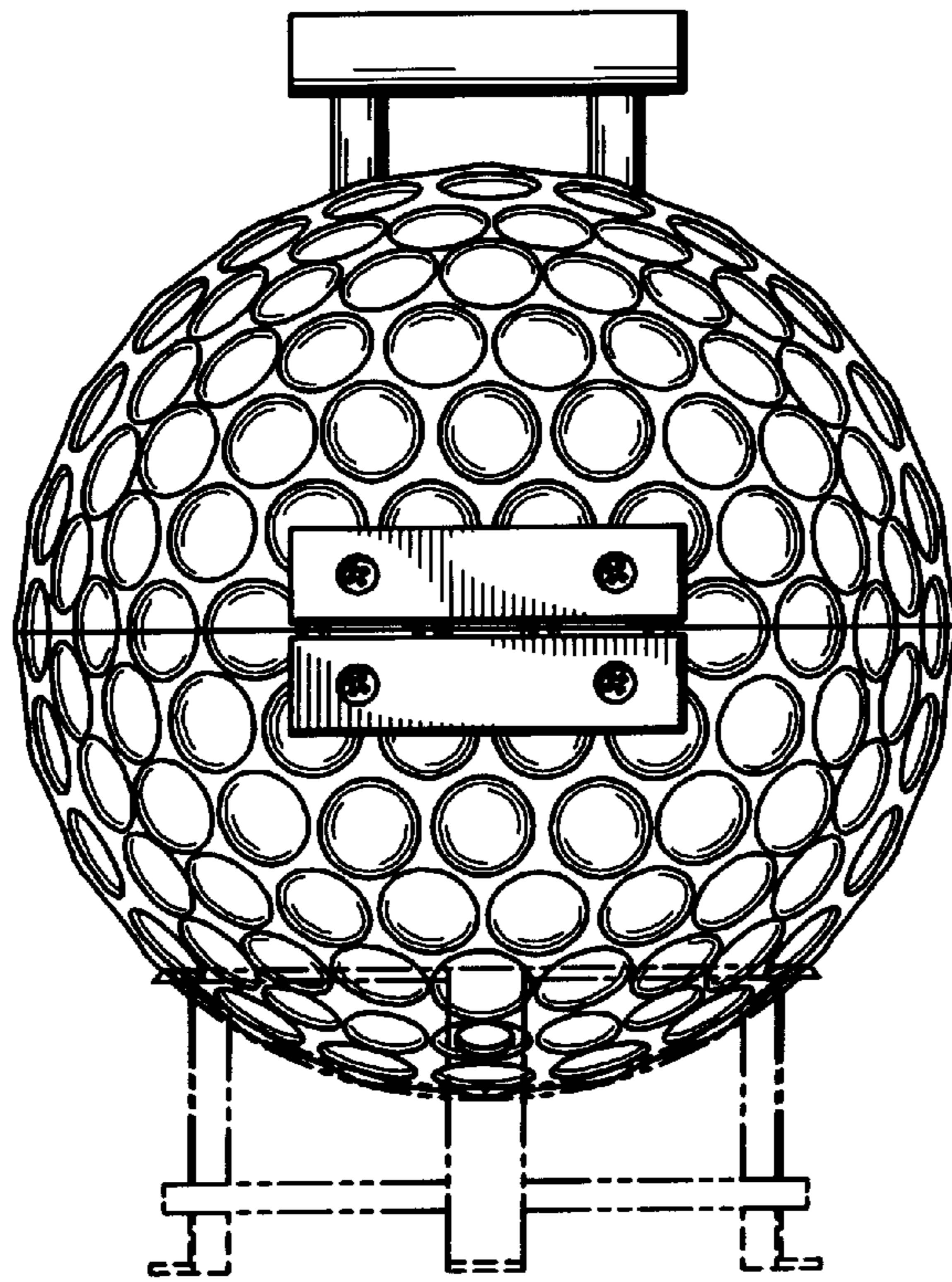
**DESCRIPTION**

FIG. 1 is a front elevational view of a portable cooking grill showing my new design;  
FIG. 2 is a rear elevational view thereof;  
FIG. 3 is a left side elevational view thereof;  
FIG. 4 is a right side elevational view thereof;  
FIG. 5 is a top plan view thereof; and,  
FIG. 6 is a bottom plan view thereof.

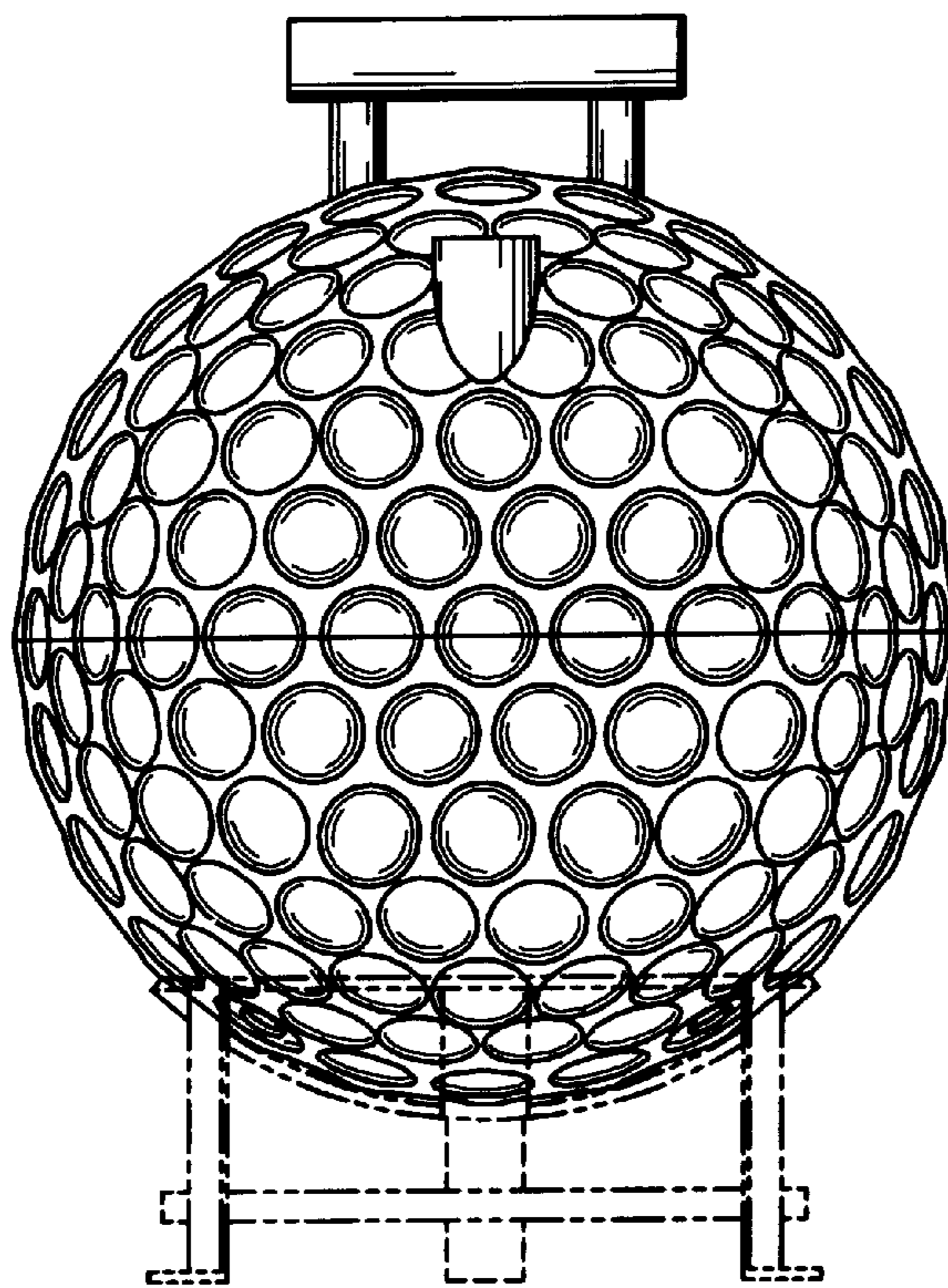
The details shown in broken lines in FIGS. 1-4 and 6 are for illustrative purposes only and form no part of the claimed design.

**1 Claim, 3 Drawing Sheets**

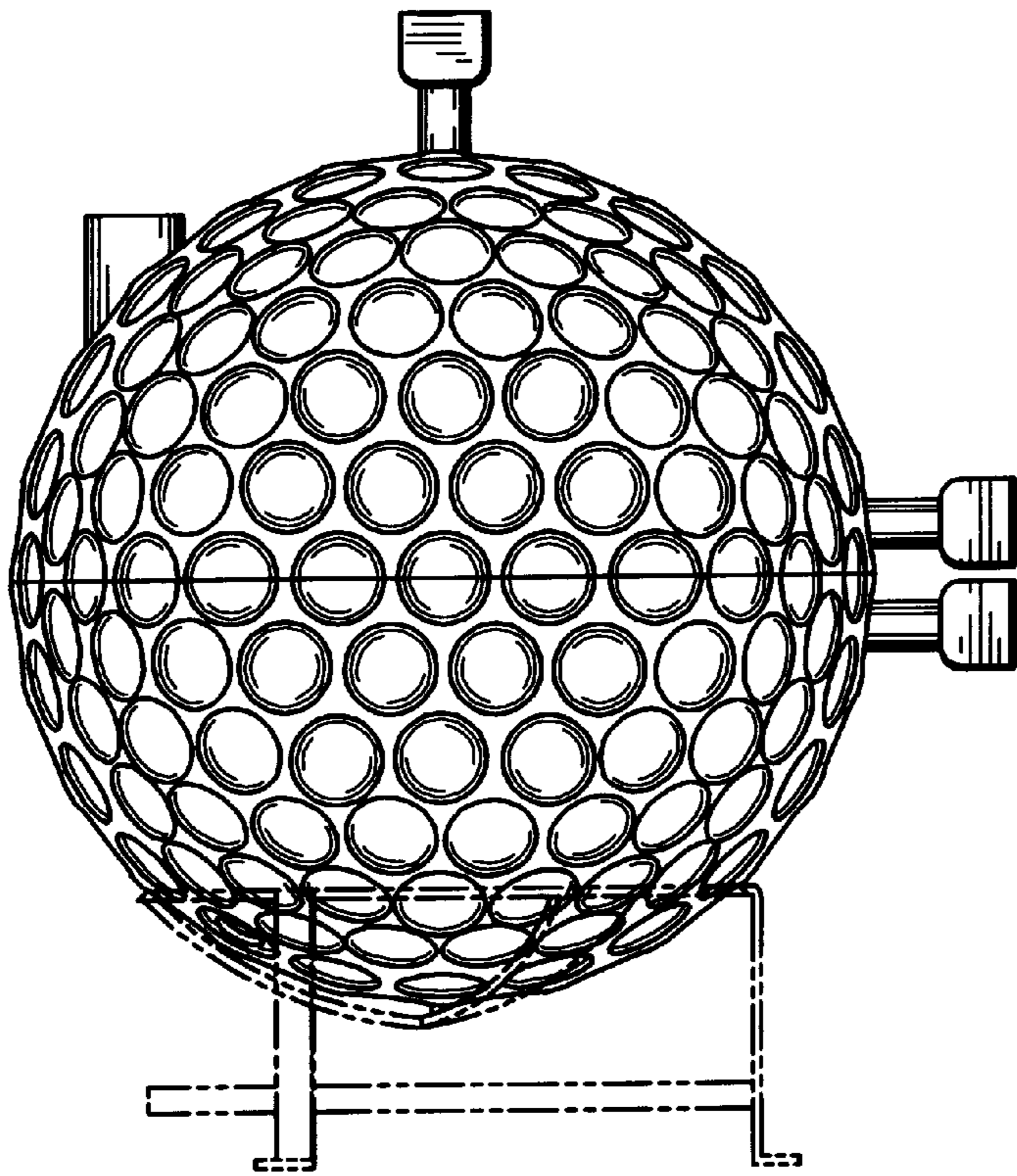




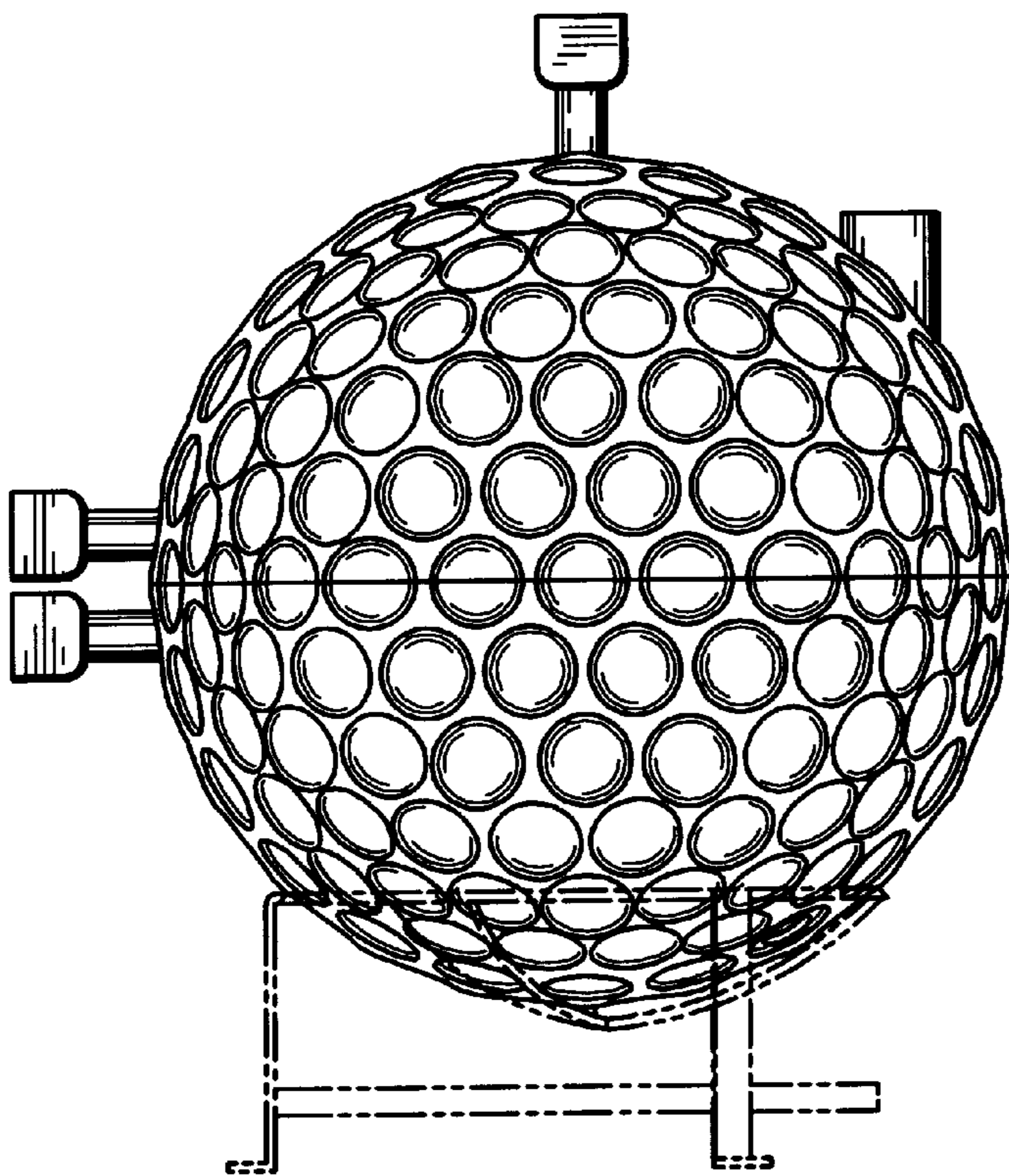
*Fig. 1*



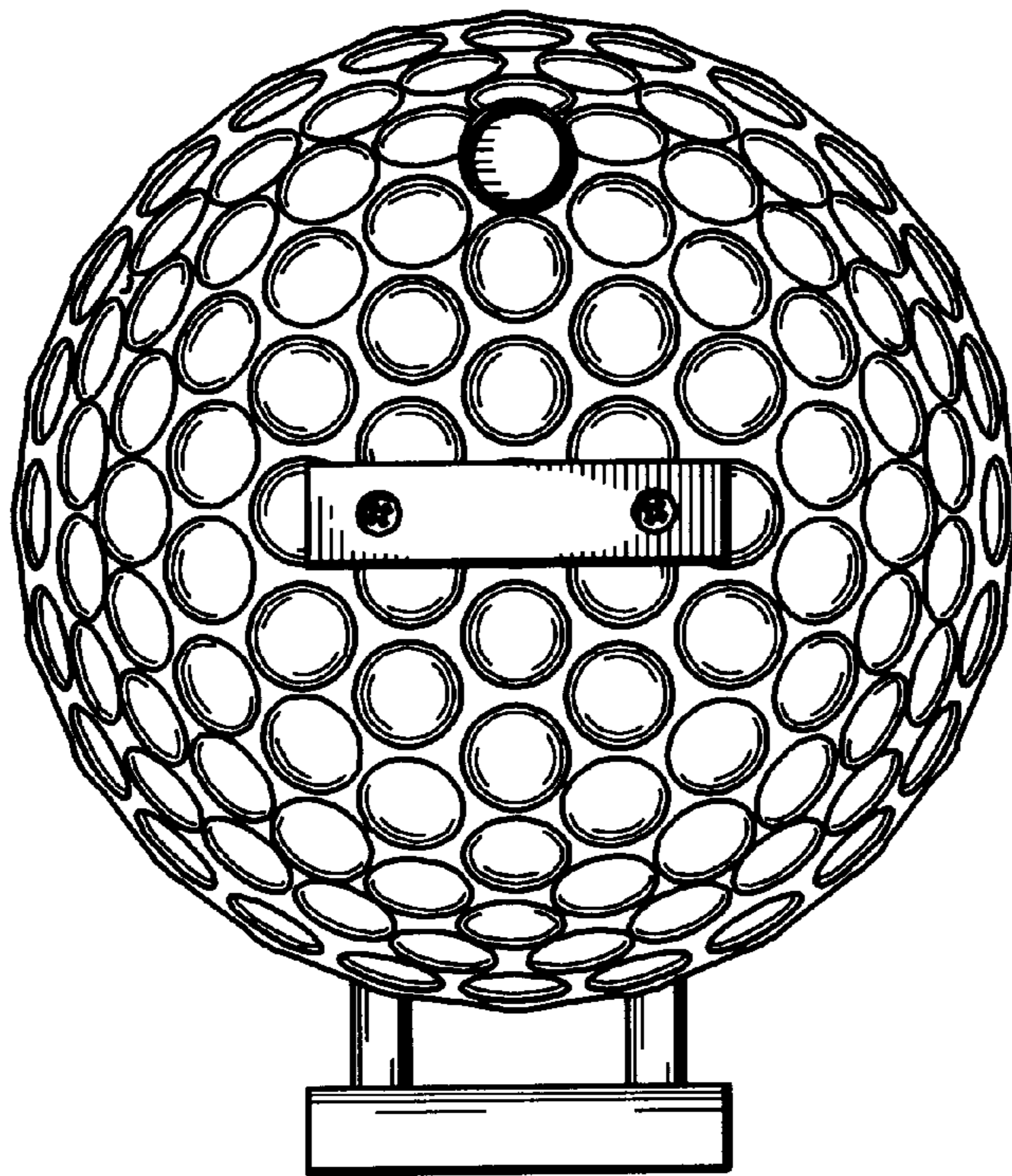
*Fig. 2*



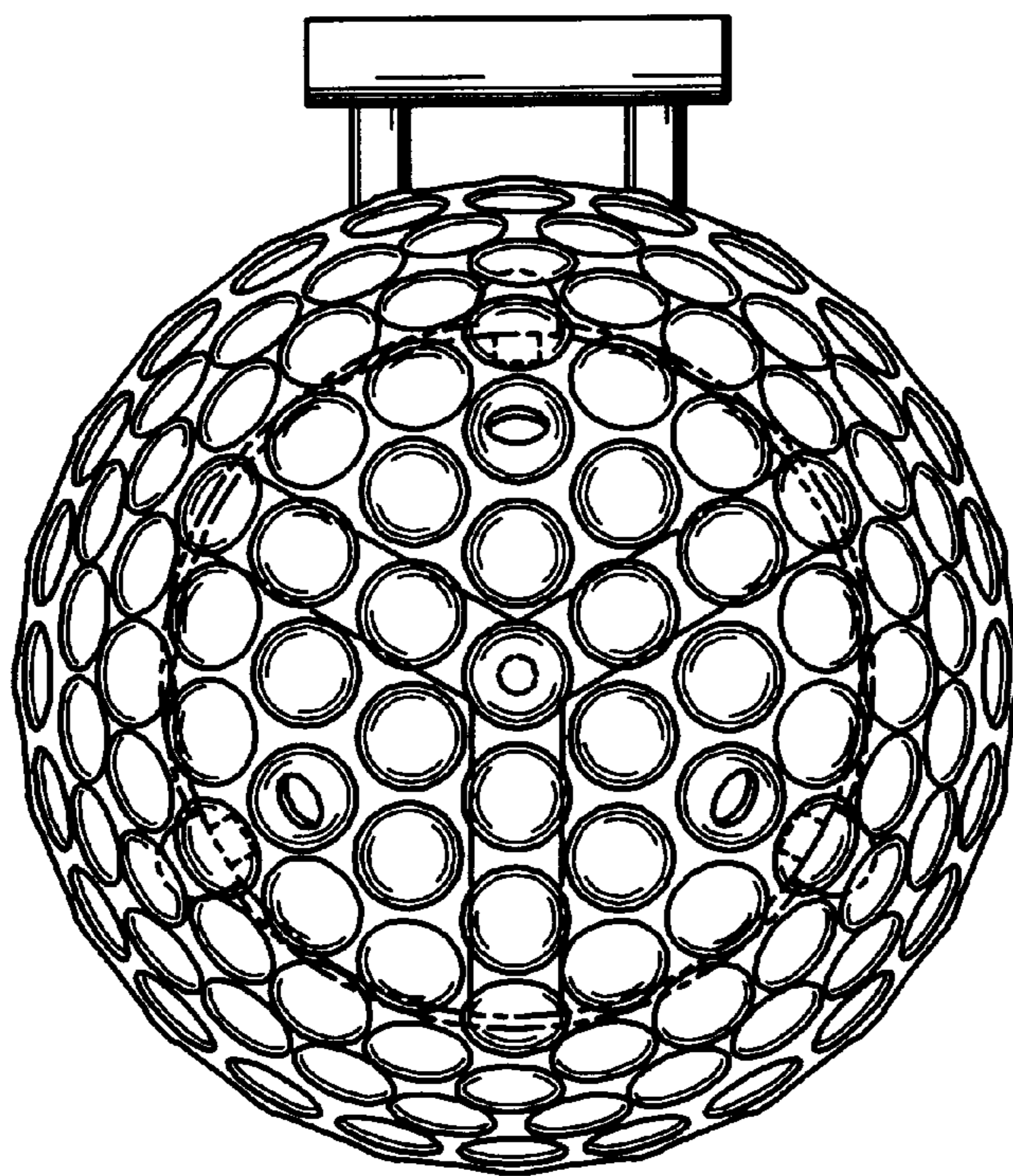
*Fig. 3*



*Fig. 4*



*Fig. 5*



*Fig. 6*