



US00D440195S

(12) **United States Design Patent**
Damon et al.

(10) **Patent No.:** **US D440,195 S**

(45) **Date of Patent:** **** Apr. 10, 2001**

(54) **PILLAR COVER FOR A TRUCK SLEEPER**

(75) Inventors: **Kenneth H. Damon**, Fort Worth; **Louis D. Heilaneh**; **Anthony M. Weiblen**, both of Lewisville, all of TX (US)

(73) Assignee: **Paccar Inc.**, Bellevue, WA (US)

(**) Term: **14 Years**

(21) Appl. No.: **29/105,110**

(22) Filed: **May 18, 1999**

(51) **LOC (7) Cl.** **12-16**

(52) **U.S. Cl.** **D12/196**

(58) **Field of Search** D12/196, 96; 296/180.1, 296/180.2, 190, 181, 89.12, 89.14, 89.16

(56) **References Cited**

U.S. PATENT DOCUMENTS

D. 248,846	8/1978	Stage et al.	D12/156
D. 299,706	2/1989	Whitmer et al.	D12/96
D. 307,731	5/1990	Kerney et al.	D12/96
D. 308,032	5/1990	Kerney et al.	D12/96
D. 312,805	12/1990	Marlowe et al.	D12/96
D. 320,583	10/1991	Simons et al.	D12/96
D. 329,214	9/1992	Marlowe et al.	D12/96
D. 384,914	10/1997	Bingaman	D12/97
D. 399,791	10/1998	Hellhake et al.	D12/96
D. 399,792	10/1998	Hellhake et al.	D12/96

D. 411,140	*	6/1999	Meryman et al.	D12/96
4,775,179		10/1988	Riggs	296/180.2
5,560,673		10/1996	Angelo	296/190

* cited by examiner

Primary Examiner—Melody N. Brown

(74) *Attorney, Agent, or Firm*—Sidley & Austin

(57) **CLAIM**

The ornamental design for a pillar cover for a truck sleeper, as shown and described.

DESCRIPTION

FIG. 1 is a perspective view of a first embodiment of a pillar cover for a truck sleeper;
FIG. 2 is a left side view thereof;
FIG. 3 is a back view thereof;
FIG. 4 is a right side view thereof;
FIG. 5 is a front view thereof;
FIG. 6 is a top view thereof;
FIG. 7 is a bottom view thereof;
FIG. 8 is a reduced perspective view of our design; and,
FIG. 9 is a perspective view of a second embodiment of a pillar cover for a truck sleeper, whereas the second embodiment is a mirror symmetrical image of the first embodiment of FIGS. 1–8.

The broken line showing of a truck, in FIG. 8, depicts environment and is not part of the claimed design.

1 Claim, 3 Drawing Sheets

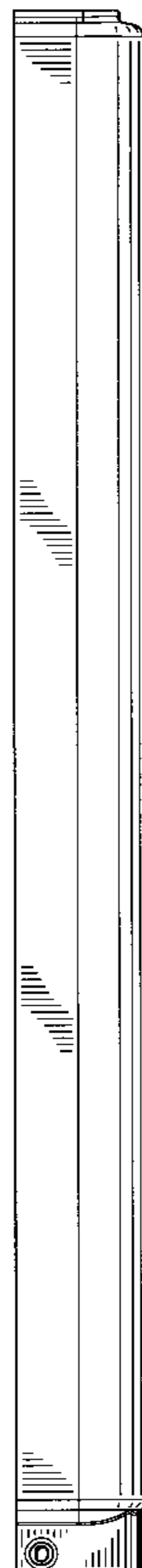



FIG. 1

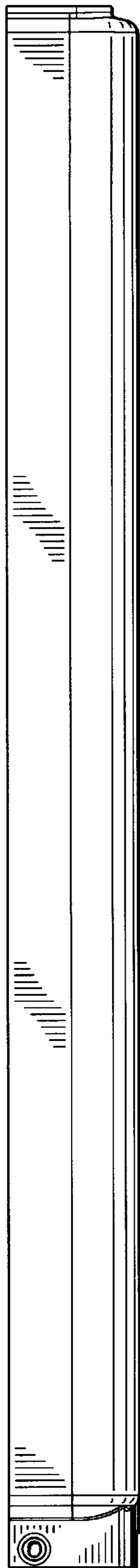

FIG. 2

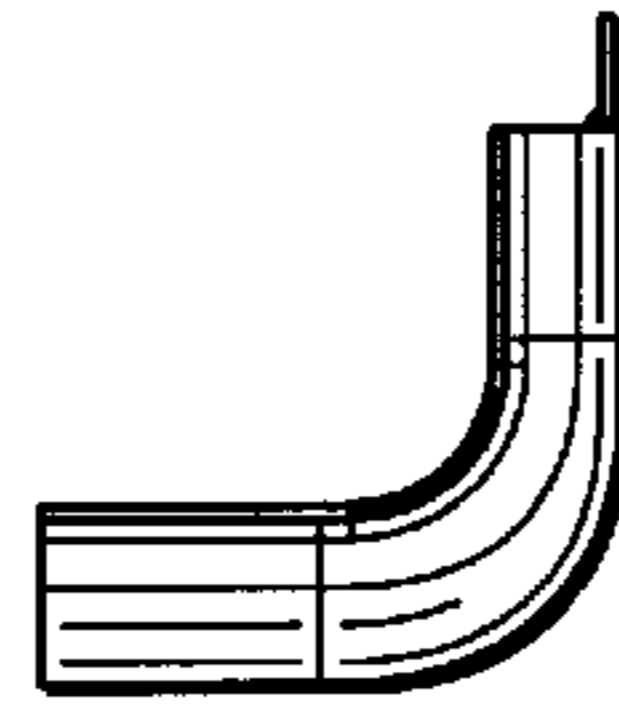

FIG. 6

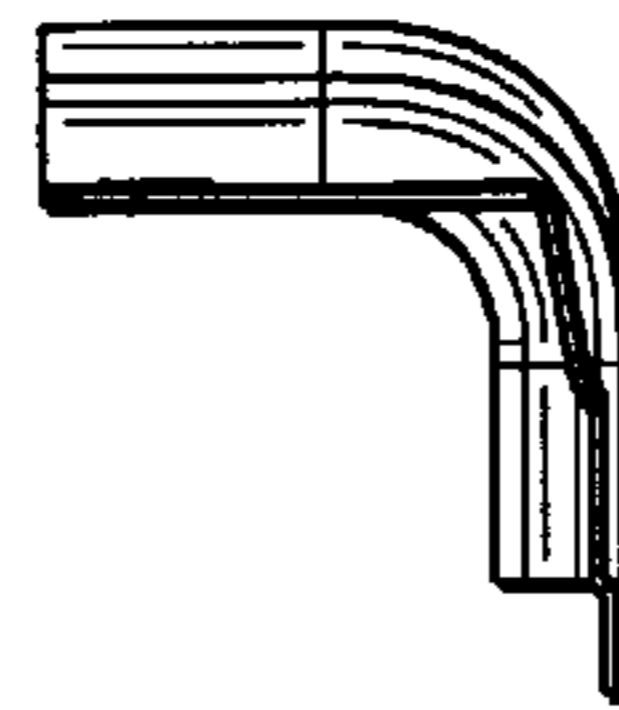

FIG. 7



FIG. 9

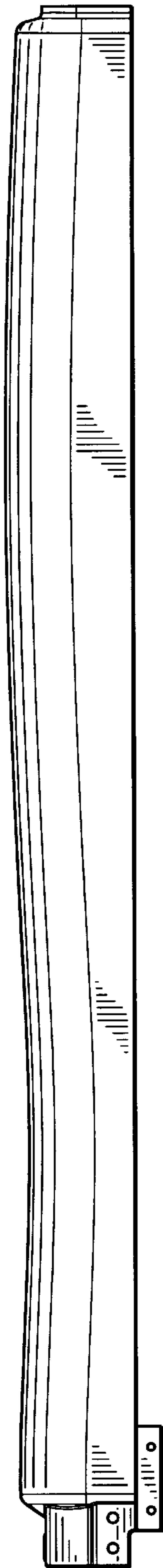

FIG. 3

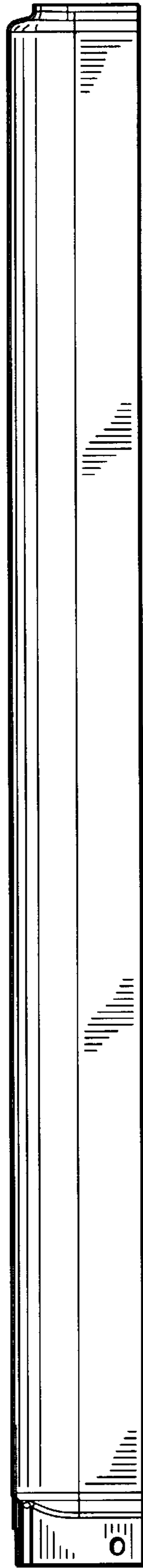

FIG. 4

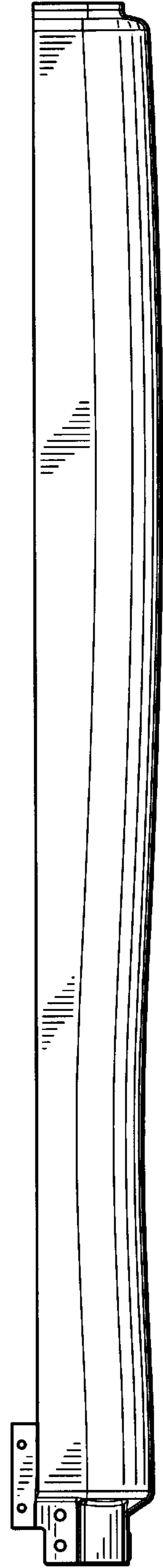

FIG. 5

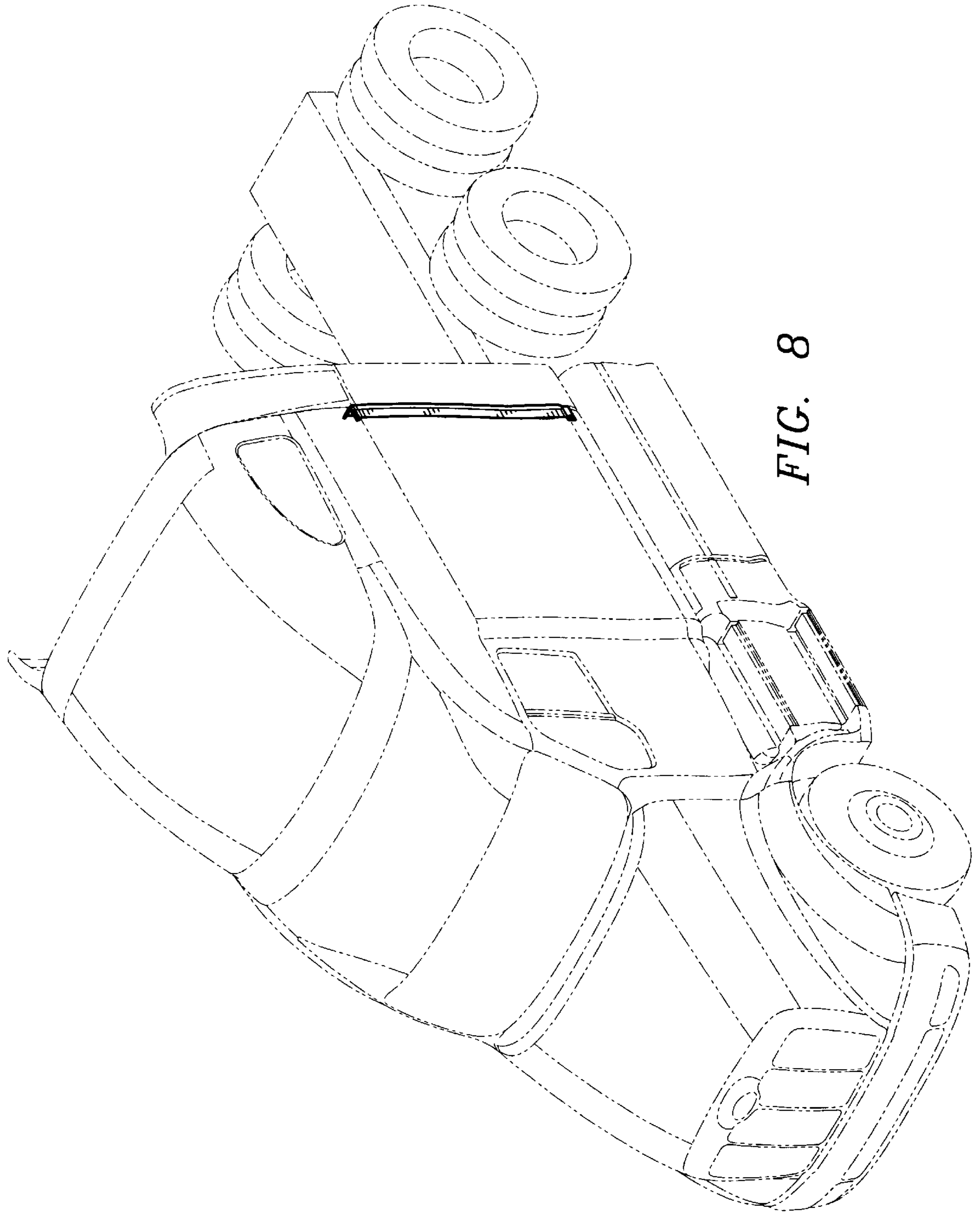

FIG. 8