



US00D440185S

(12) **United States Design Patent**  
**Desmond et al.**

(10) **Patent No.:** **US D440,185 S**

(45) **Date of Patent:** **\*\* Apr. 10, 2001**

(54) **VEHICLE BODY**

D. 425,449 \* 5/2000 Sims et al. .... D12/92

(75) Inventors: **Michael Desmond**, Longbeach;  
**Jonathan Hull**, Huntington Beach, both  
of CA (US)

\* cited by examiner

*Primary Examiner*—Melody N. Brown

(73) Assignee: **Mitsubishi Jidosha Kogyo Kabushiki**  
**Kaisha**, Tokyo (JP)

(57) **CLAIM**

The ornamental design for a vehicle body, as shown and  
described.

(\*\*) Term: **14 Years**

**DESCRIPTION**

(21) Appl. No.: **29/115,606**

FIG. 1 is a front and right perspective elevational view of the  
vehicle body;

(22) Filed: **Dec. 20, 1999**

FIG. 2 is a right side perspective view of the vehicle body;

(51) **LOC (7) Cl.** ..... **12-08**

FIG. 3 is a top plan view of the vehicle body;

(52) **U.S. Cl.** ..... **D12/91**

FIG. 4 is a front view of the vehicle body;

(58) **Field of Search** ..... D12/90-92, 86;  
296/185

FIG. 5 is a rear view of the vehicle body; and,

FIG. 6 is a rear and right perspective elevational view of the  
vehicle body.

(56) **References Cited**

The broken lines showing of environmental structure in  
FIGS. 1, 2, 3, 4, 5, and 6 are for illustrative purposes only  
and form no part of the claimed design.

**U.S. PATENT DOCUMENTS**

D. 397,961 \* 9/1998 Mays et al. .... D12/91

D. 419,486 \* 1/2000 Crain et al. .... D12/91

**1 Claim, 5 Drawing Sheets**

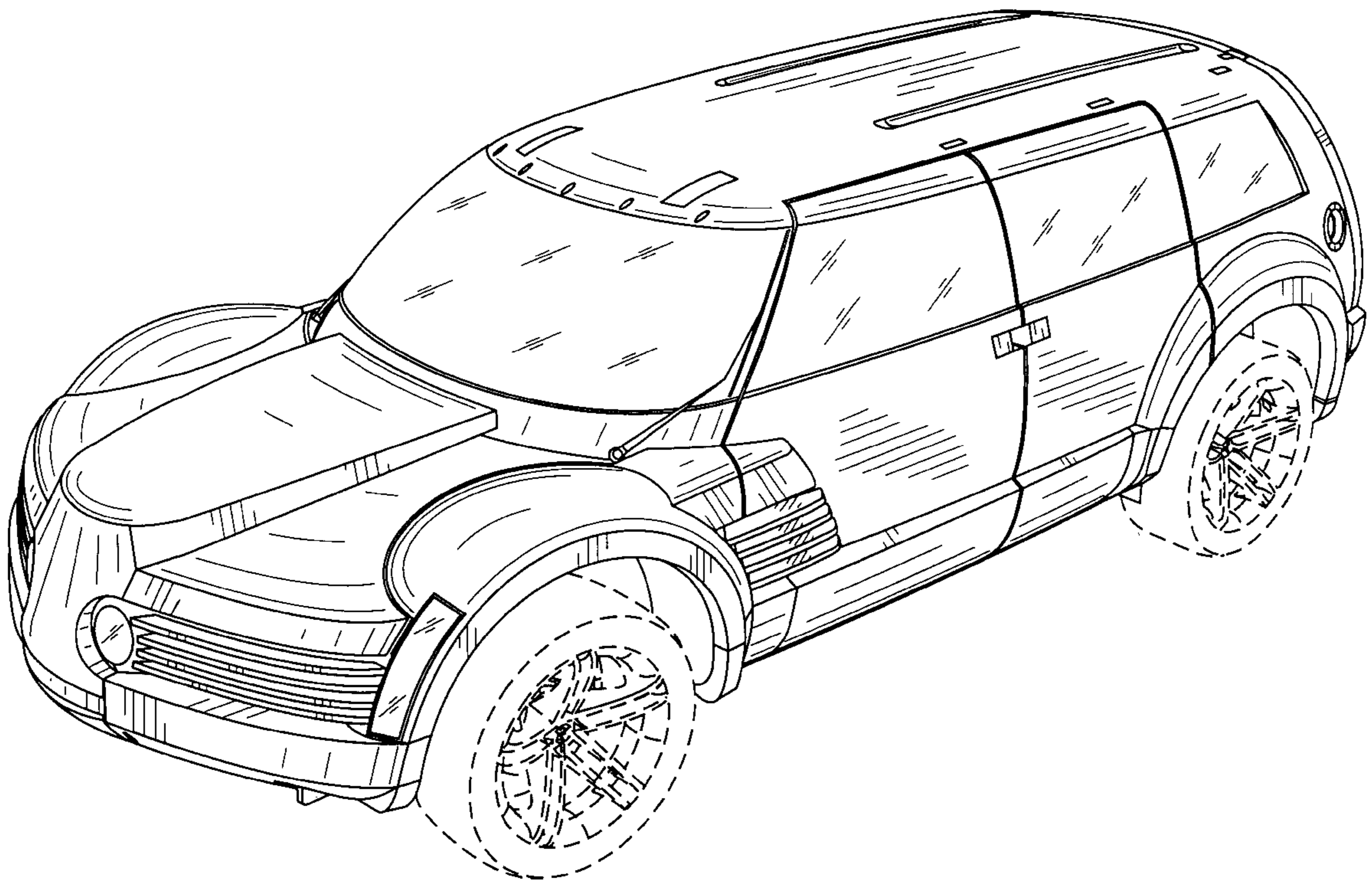

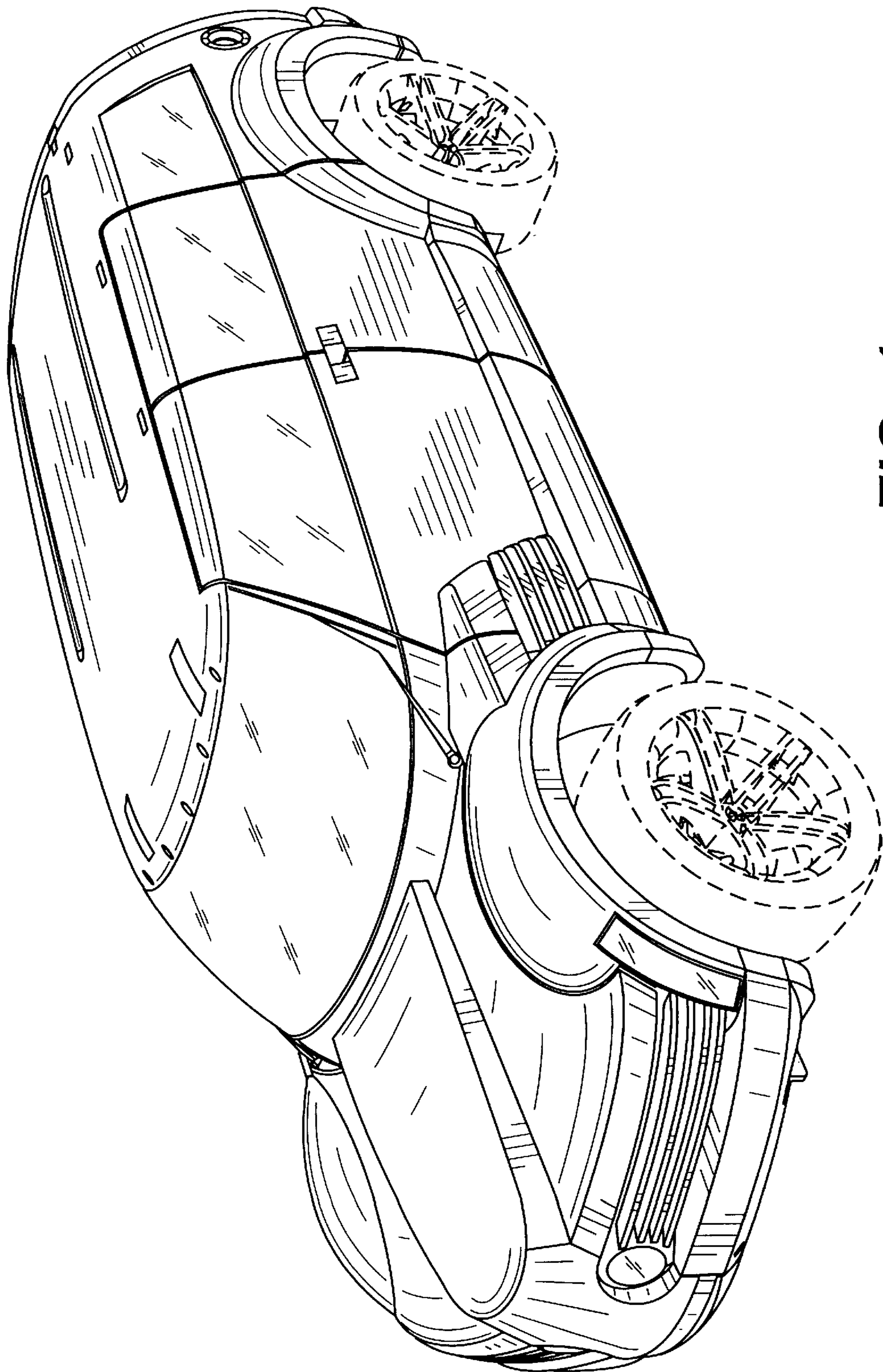

FIG. 1

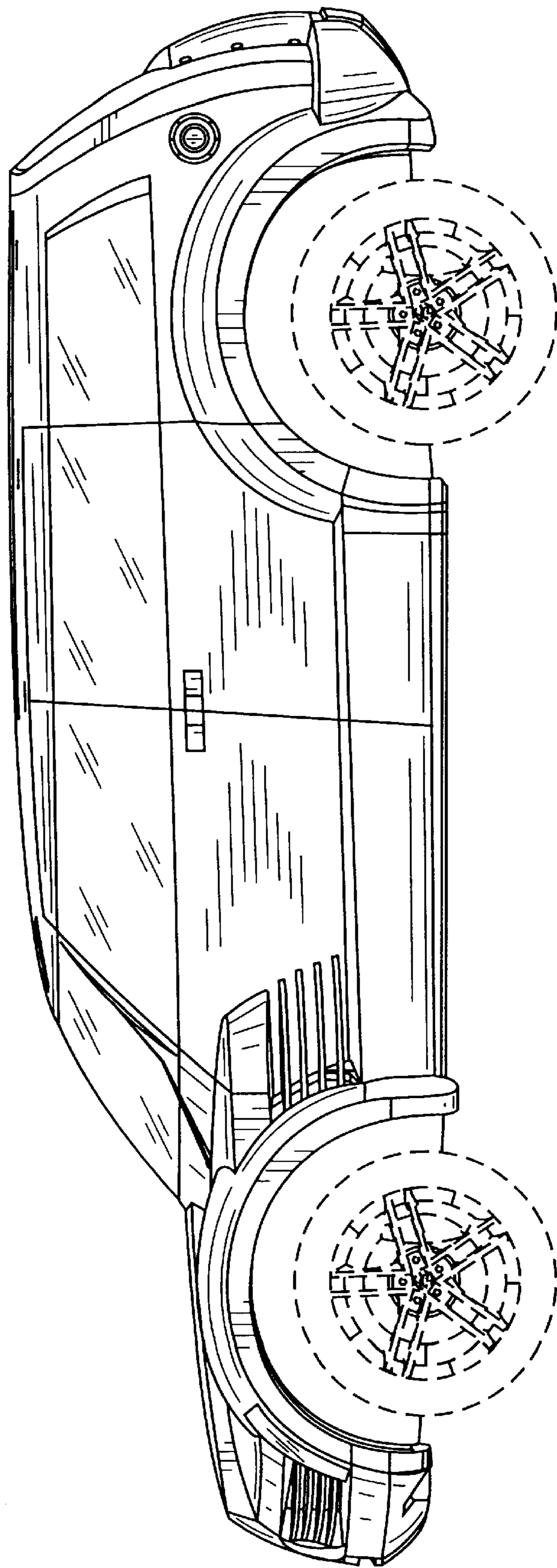
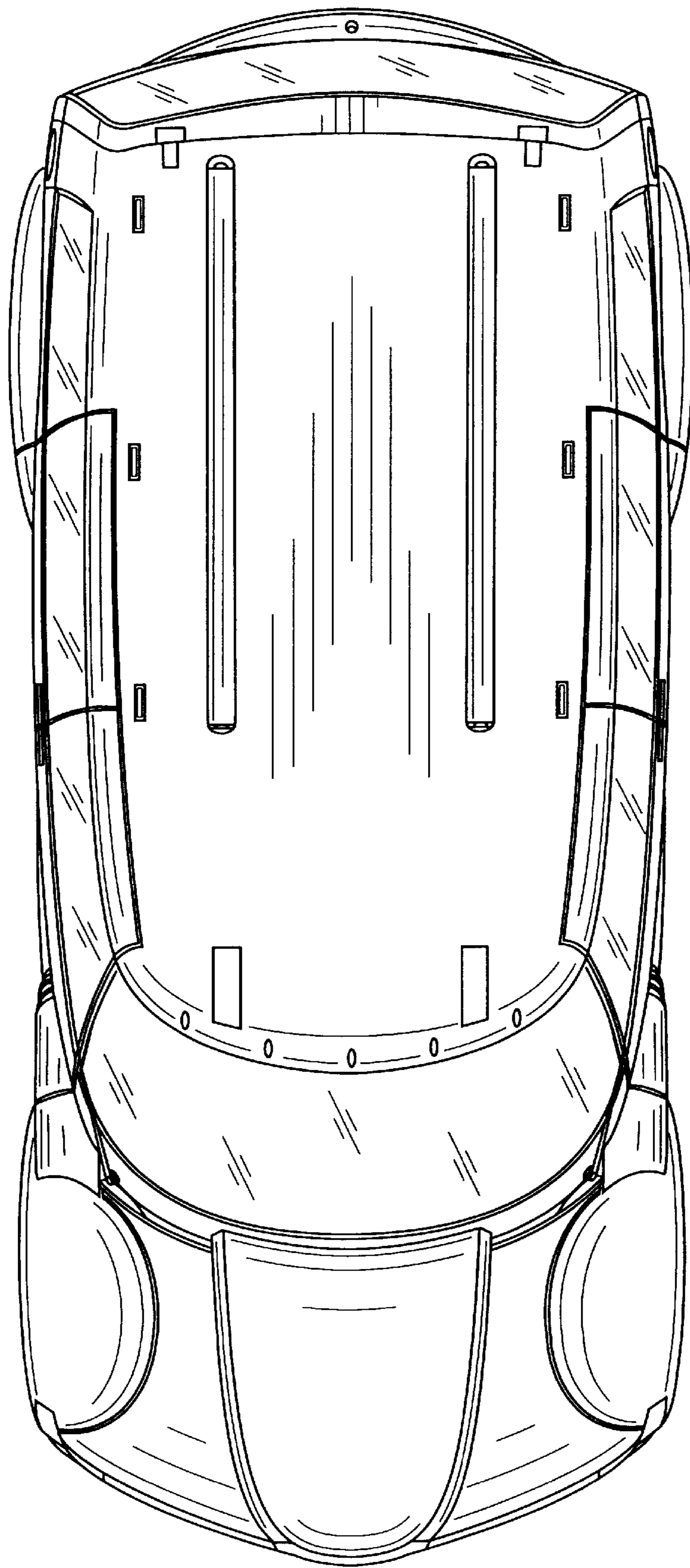
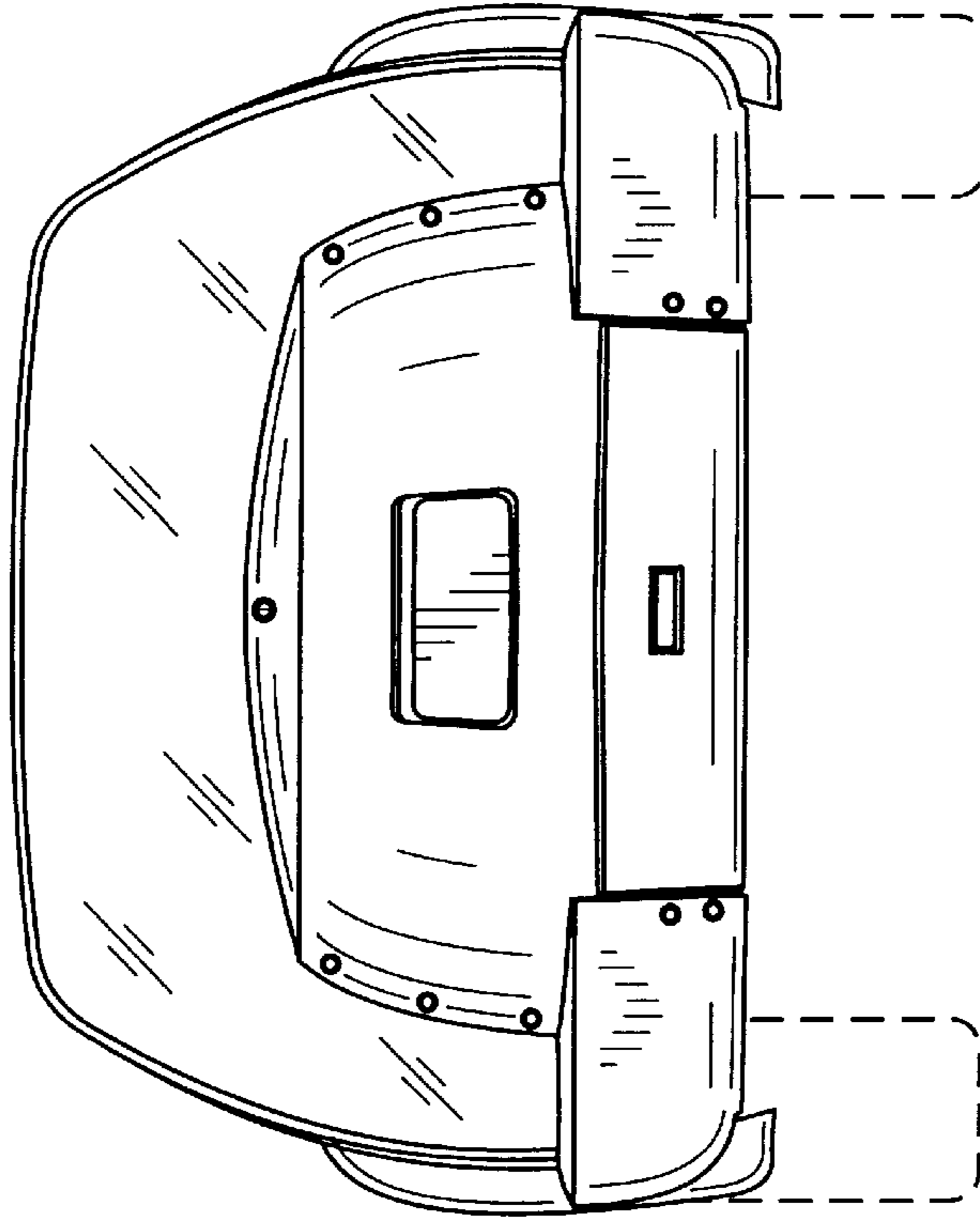

FIG. 2



**FIG. 3**



**FIG. 4**

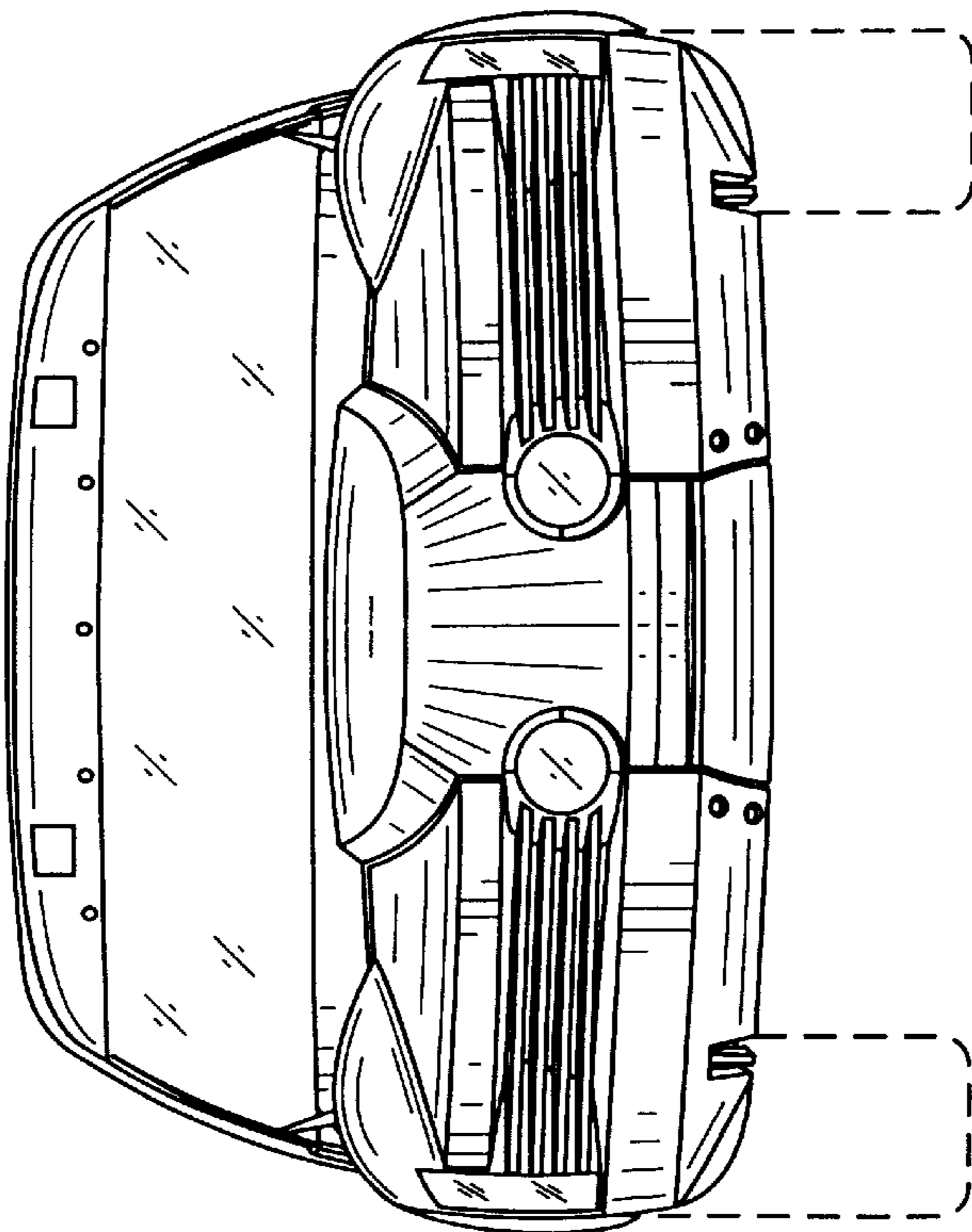

**FIG. 5**

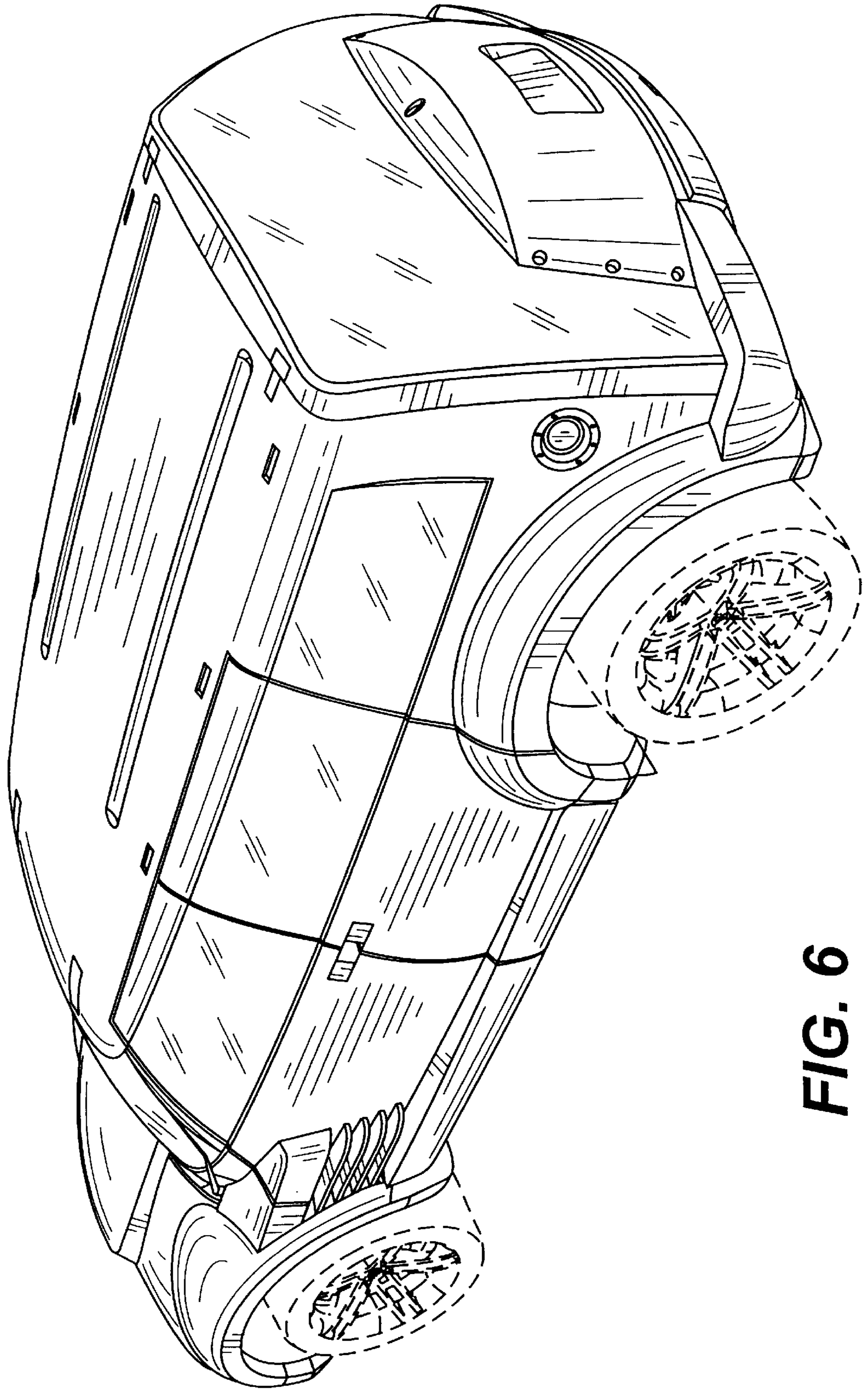

**FIG. 6**