



US00D440042S

(12) **United States Design Patent**
Holahan

(10) **Patent No.:** **US D440,042 S**

(45) **Date of Patent:** **** Apr. 10, 2001**

(54) **ENGINE CASE WITH REMOVABLE INSERT**

(75) Inventor: **Anthony F. Holahan**, Costa Mesa, CA (US)

(73) Assignee: **Hoover Materials Handling Group**, Costa Mesa, CA (US)

(**) Term: **14 Years**

(21) Appl. No.: **29/107,643**

(22) Filed: **Jul. 9, 1999**

(51) **LOC (7) Cl.** **03-01**

(52) **U.S. Cl.** **D3/272; D3/302**

(58) **Field of Search** **D3/272, 273, 302, D3/905, 423, 424; 206/319, 508, 503, 515; 220/1.5**

(56) **References Cited**

U.S. PATENT DOCUMENTS

D. 201,398	*	6/1965	Burns et al.	D3/302
D. 237,145	*	10/1975	Barr	D3/272
D. 245,319	*	8/1977	Wodell	D3/272
D. 252,354	*	7/1979	Uyeda	D3/302
D. 328,188	*	7/1992	Jacobsen et al.	D3/272
D. 389,307	*	1/1998	Zimmerman	D3/273
D. 413,439	*	9/1999	Bell	D3/272
4,735,310	*	4/1988	Lemery et al.	206/319
5,004,102	*	4/1991	Timmins et al.	203/319

OTHER PUBLICATIONS

Brochure by Endural, Automotive and transportation Division, "Returnable Engine Cases", undated.

Brochure by Endural, Automotive and Transportation Division, "Returnable, Stackable, Storable Transmission Cases", undated.

* cited by examiner

Primary Examiner—Philip S. Hyder

(74) *Attorney, Agent, or Firm*—Wood, Phillips, VanSanten, Clark & Mortimer

(57) **CLAIM**

The ornamental design for a engine case with removable insert, as shown and described.

DESCRIPTION

FIG. 1 is a perspective view of an engine case showing our new design;

FIG. 2 is a right side elevation view thereof, the left side view being identical to the right side view;

FIG. 3 is a front elevation view thereof, the rear view being identical to the front view;

FIG. 4 is a top plan view thereof;

FIG. 5 is a bottom plan view thereof;

FIG. 6 is a perspective view of a removable insert showing our new design insert being removably receivable in an interior space of the engine case and resting on a bottom wall of the case;

FIG. 7 is a right side elevation view thereof;

FIG. 8 is a left side elevation view thereof;

FIG. 9 is a front elevation view thereof, the rear view being identical to the front view;

FIG. 10 is a top plan view thereof; and,

FIG. 11 is a bottom plan view thereof.

The removable insert has been shown separate from the engine case for clarity of illustration.

1 Claim, 5 Drawing Sheets

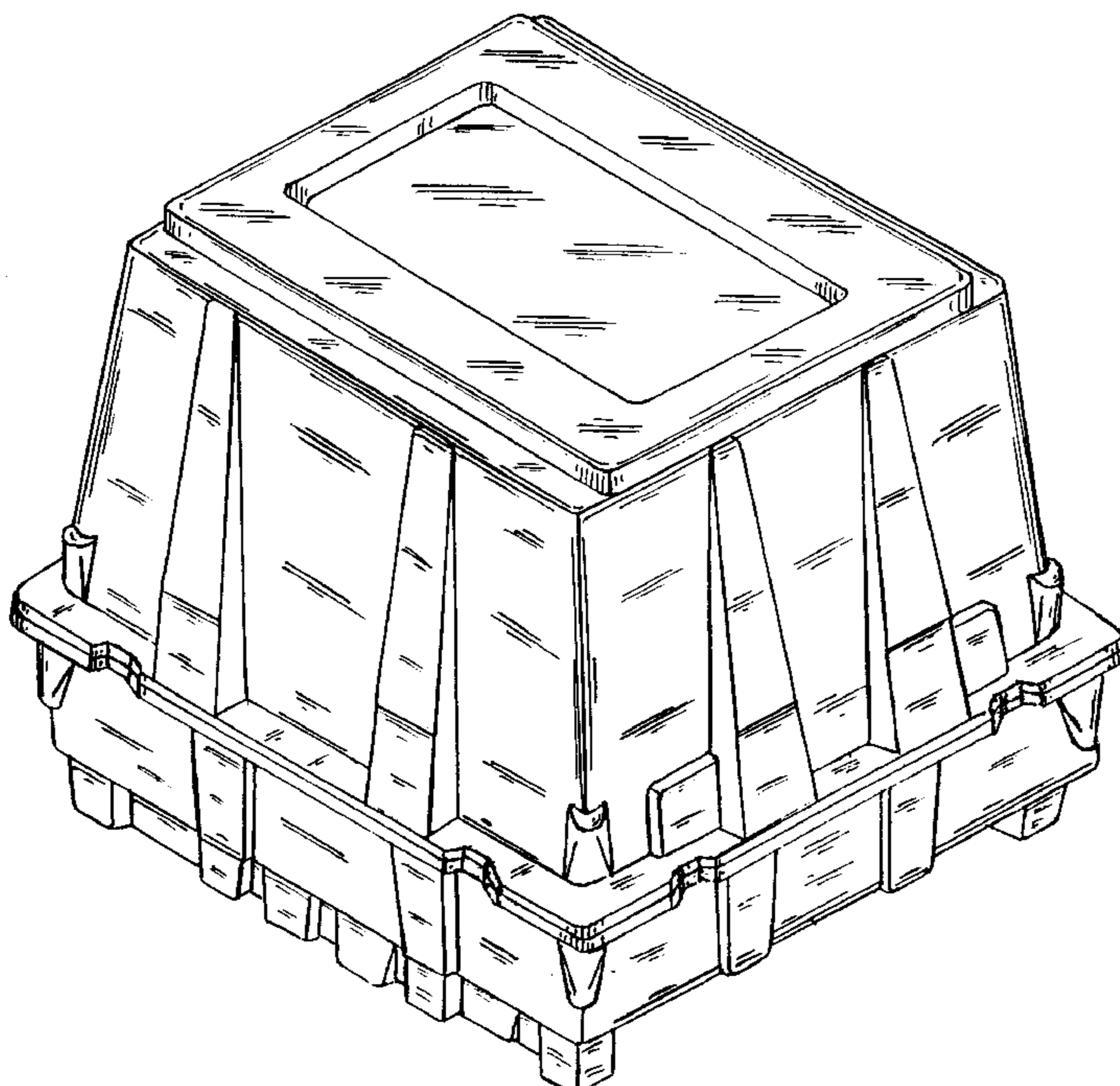

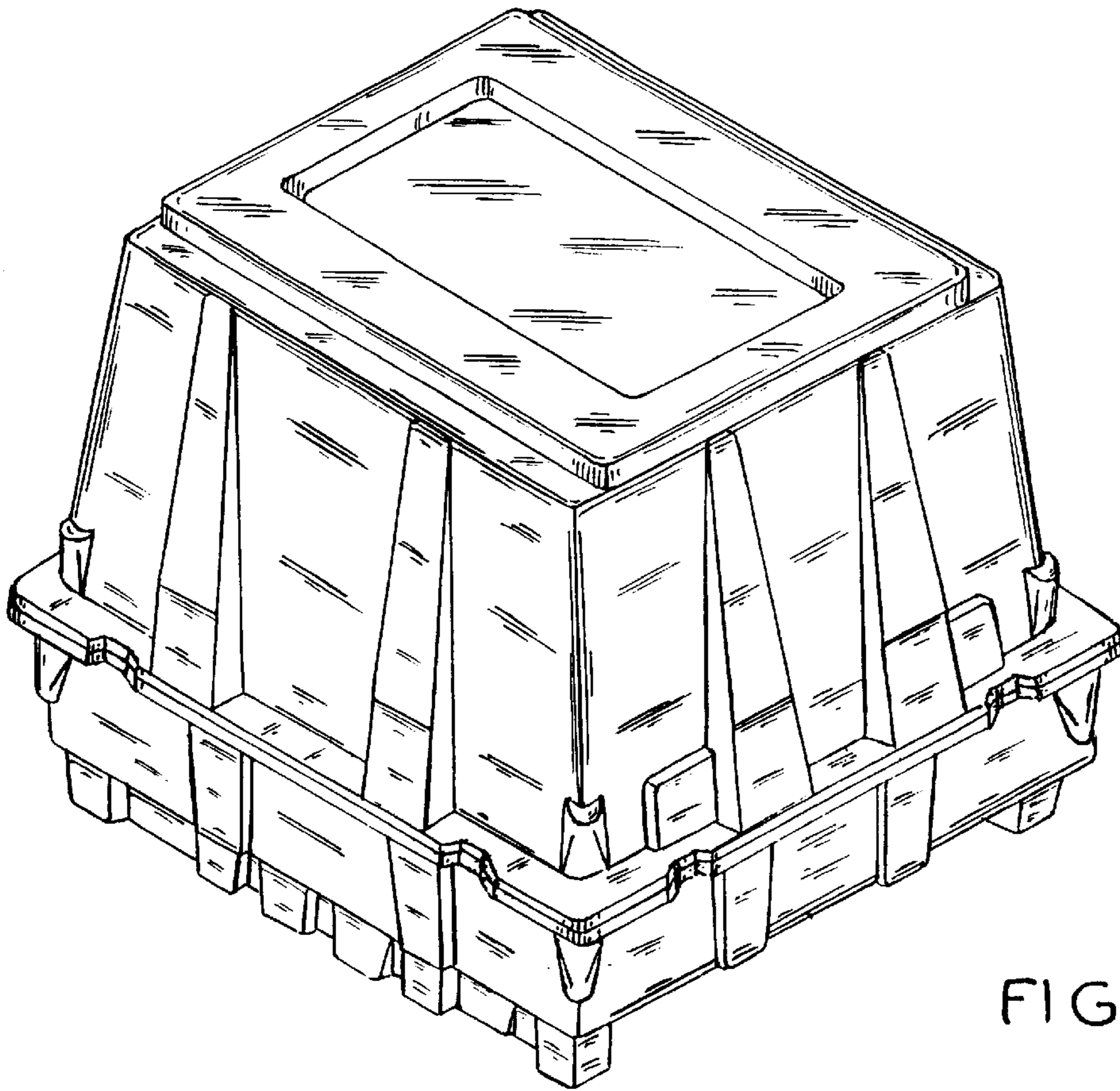

FIG. 1

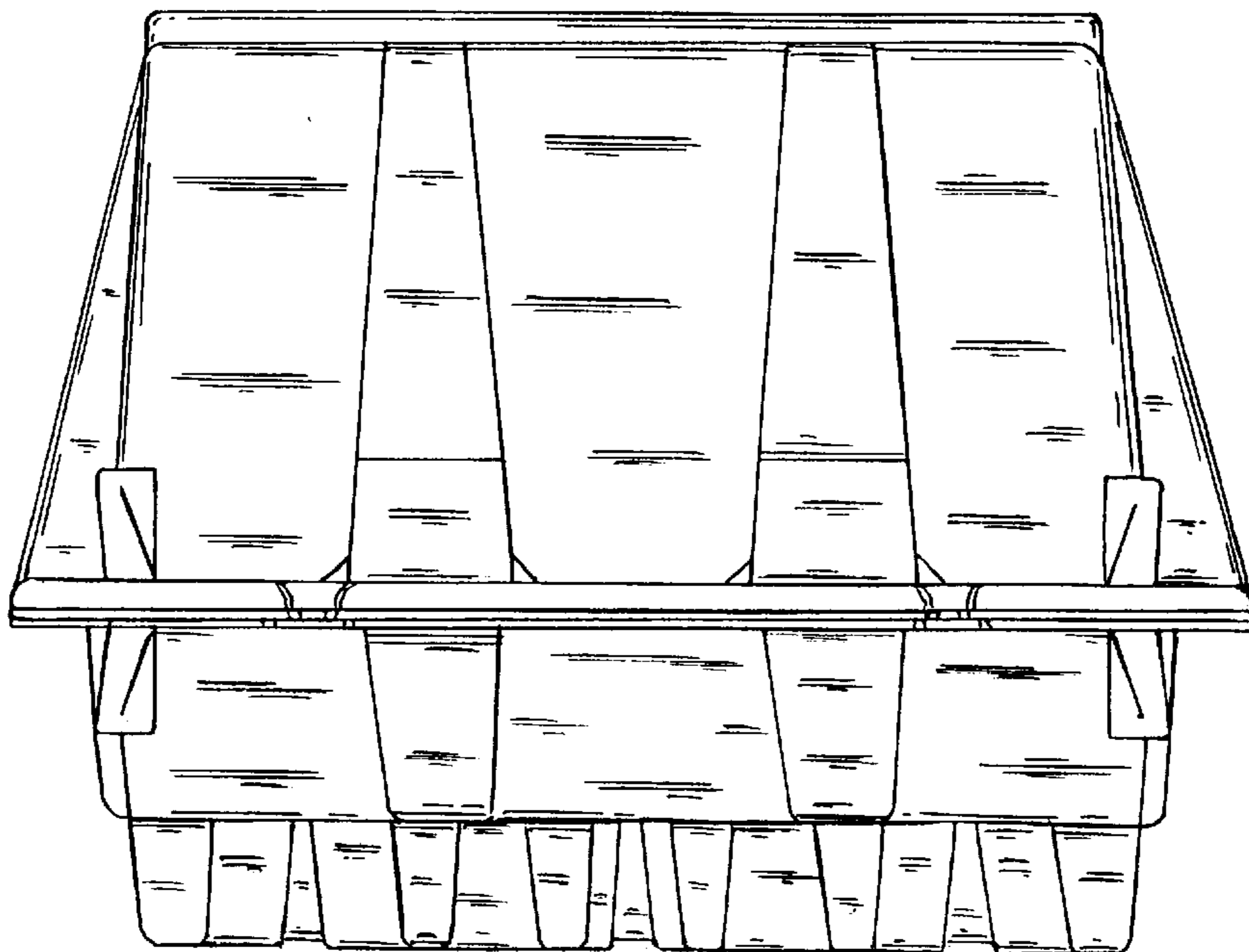

FIG. 2

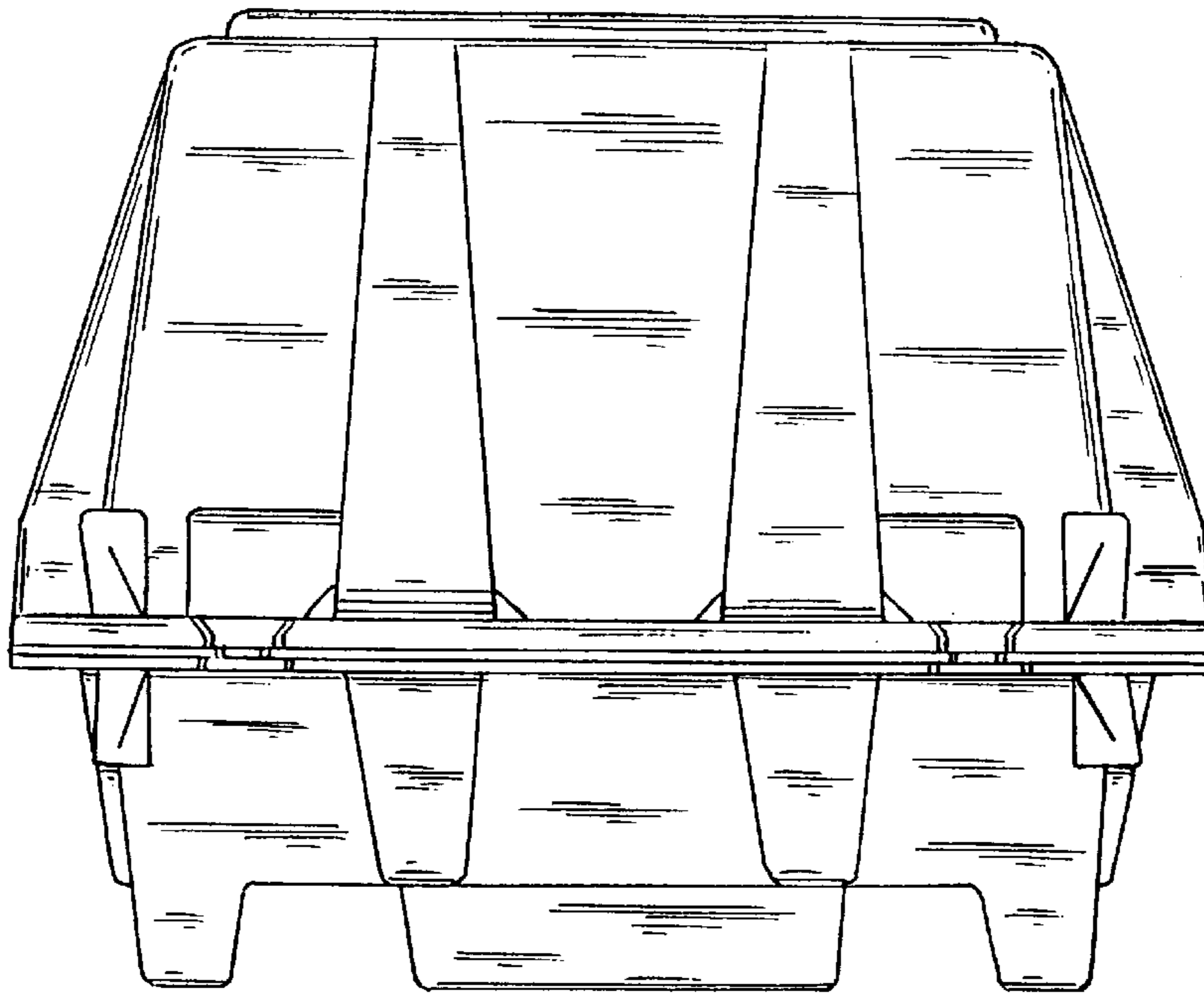

FIG. 3

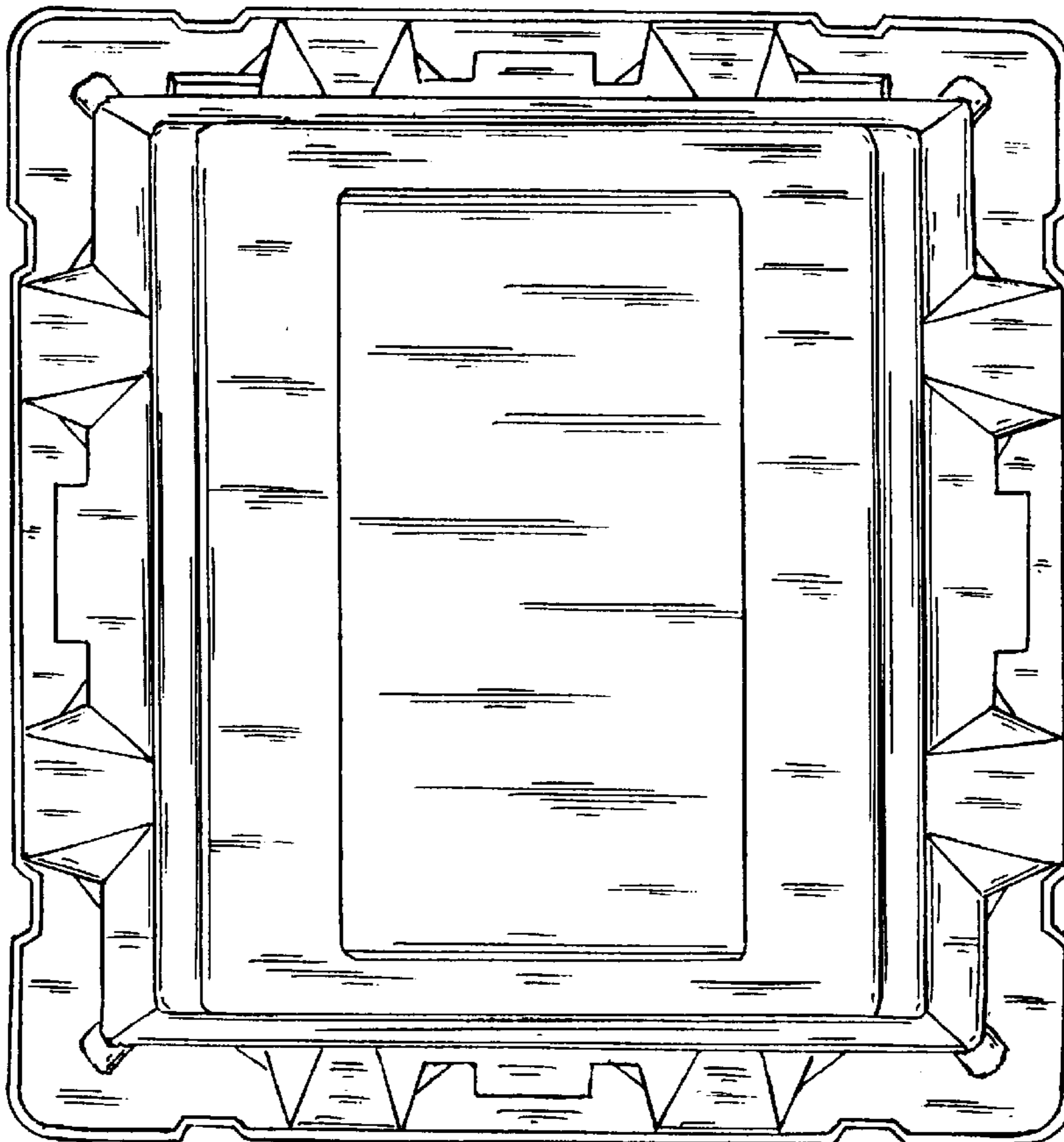

FIG. 4

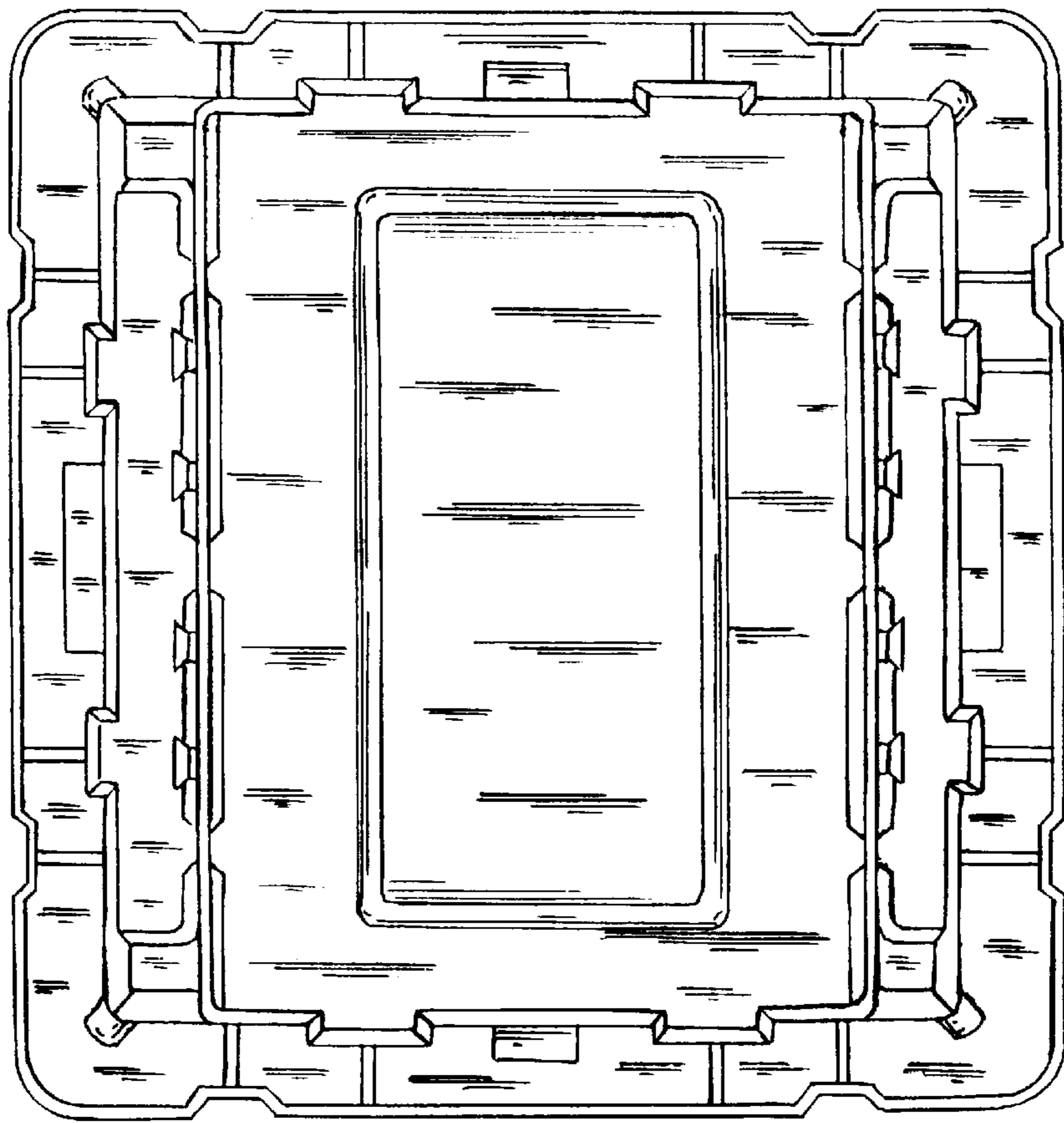

FIG. 5

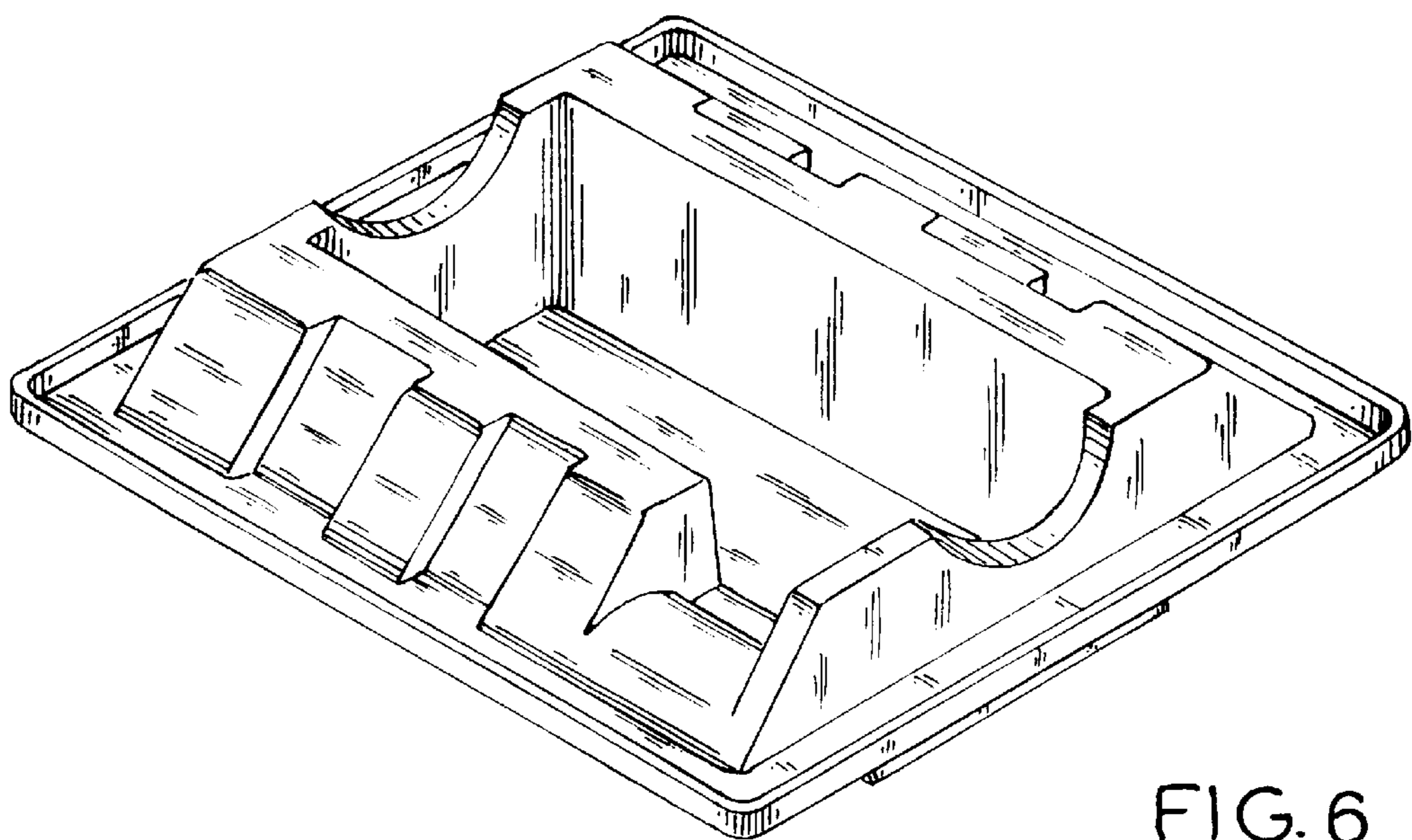

FIG. 6

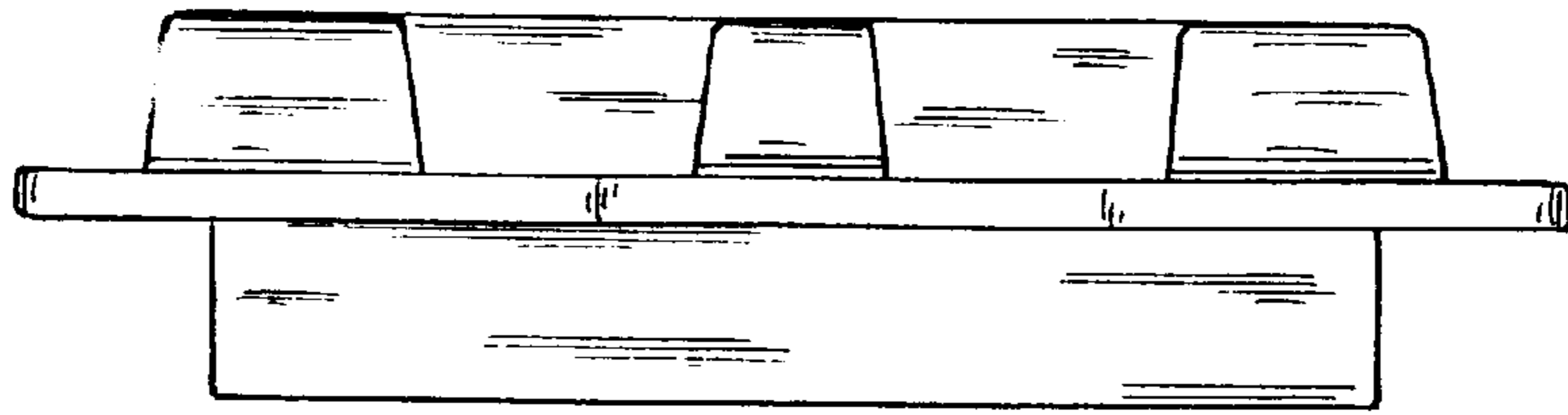

FIG. 7

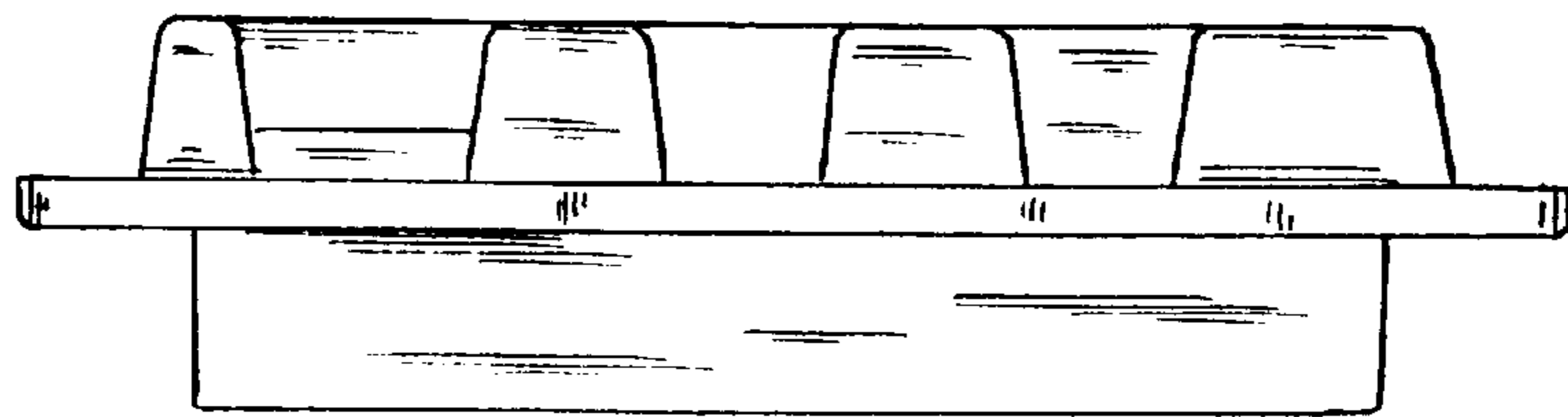

FIG. 8

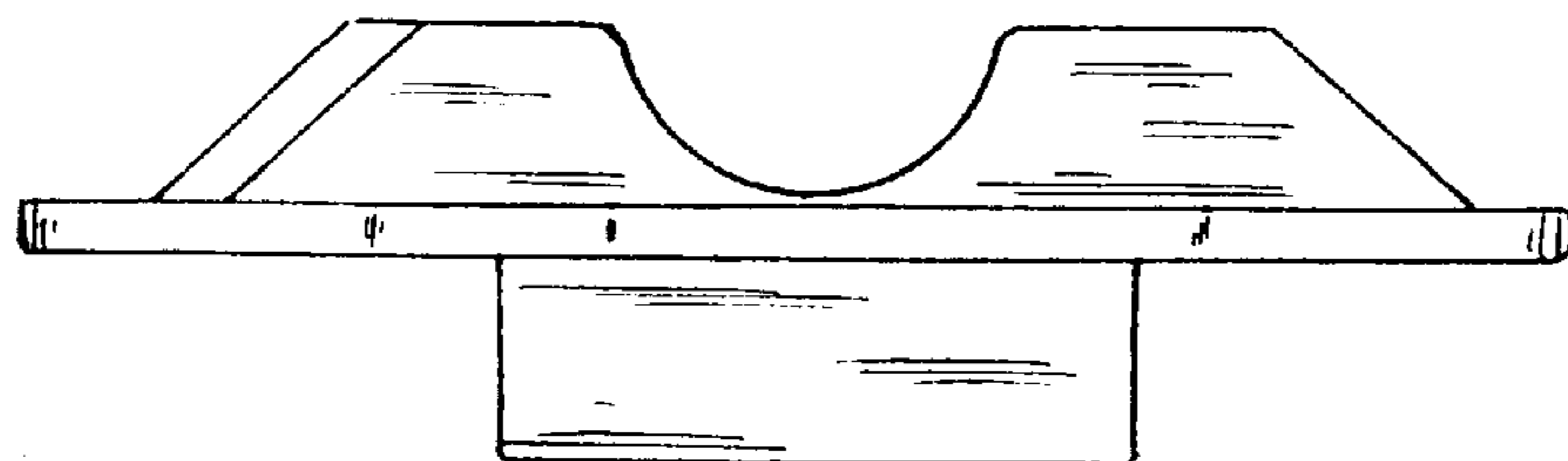

FIG. 9

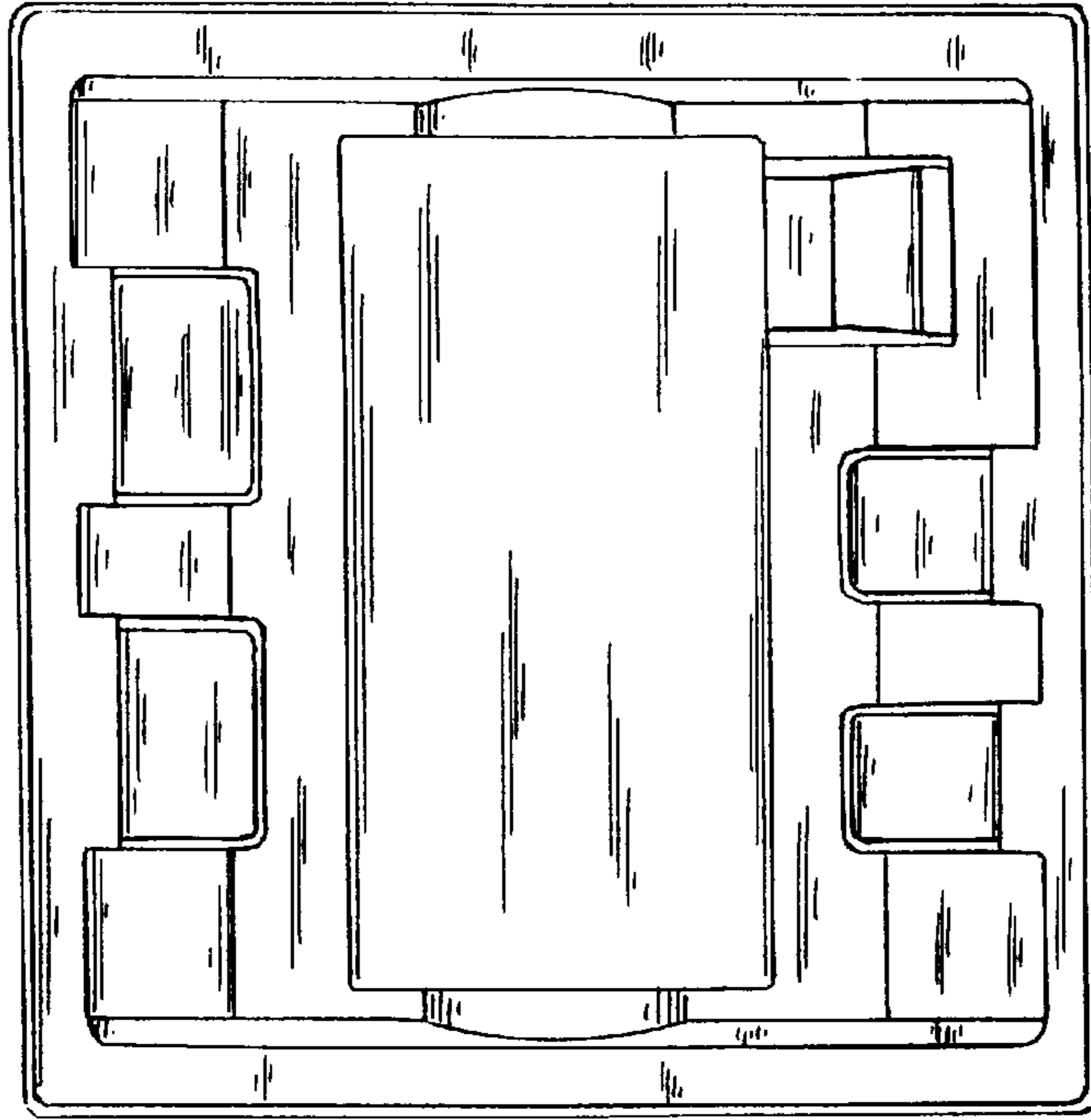

FIG. 10

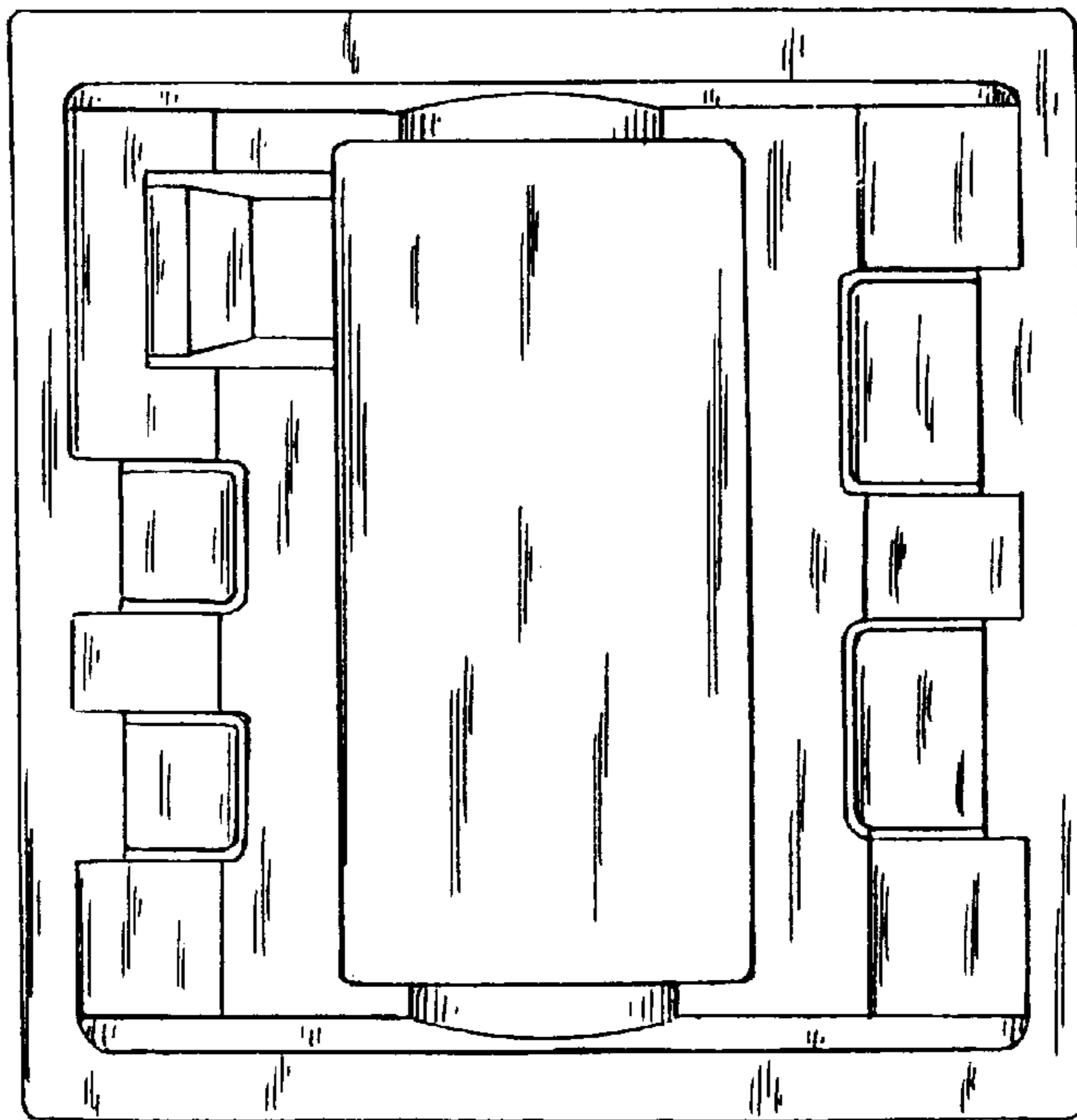

FIG. 11