



US00D439876S

(12) **United States Design Patent**
Simonov et al.

(10) **Patent No.:** **US D439,876 S**

(45) **Date of Patent:** **** Apr. 3, 2001**

(54) **SUPERSONIC AIRCRAFT WITH IN-FLIGHT REFUELING SYSTEM**

(75) Inventors: **Mikhail P. Simonov**, Moscow; **Viktor I. Merkulov**, Khabarovsk Territory; **Yury L. Ivanov**; **Konstantin K. Marbashev**, both of Moscow; **Aleksandr Y. Maranov**, Khabarovsk Territory; **Anatoly S. Klyagin**; **Leonid G. Chernov**, both of Moscow, all of (RU)

(73) Assignee: **Zakrytoe Actionsnoe Obshchestvo "Otdelenie morskikh sistem OKB im. P.O. Sukhogo"**, Moscow (RU)

(**) Term: **14 Years**

(21) Appl. No.: **29/103,739**

(22) Filed: **Apr. 22, 1999**

(51) **LOC (7) Cl.** **12-07**

(52) **U.S. Cl.** **D12/342; D12/319; D12/333**

(58) **Field of Search** **D12/319-345; 244/15, 45 A, 12, 5, 52**

(56) **References Cited**

U.S. PATENT DOCUMENTS

- D. 317,897 * 7/1991 Antonov et al. D12/342
- D. 319,042 * 8/1991 Babak et al. D12/342

- D. 332,080 * 12/1992 Sandusky, Jr. et al. D12/342
- 4,643,374 * 2/1987 Friederich 244/52
- 4,896,846 * 1/1990 Strom 244/45 A
- 5,526,999 * 6/1996 Meston 244/2

FOREIGN PATENT DOCUMENTS

44033 1/1998 (RU) .

* cited by examiner

Primary Examiner—Kay H. Chin

(74) *Attorney, Agent, or Firm*—Oblon, Spivak, McClelland, Maier & Neustadt, P.C.

(57) **CLAIM**

The ornamental design for supersonic aircraft with in-flight refueling system, as shown and described.

DESCRIPTION

FIG. 1 is a top, front and left side perspective view of supersonic aircraft with in-flight refueling system, embodying our new design;

FIG. 2 is a left side elevational view thereof;

FIG. 3 is a front elevational view thereof;

FIG. 4 is a rear elevational view thereof;

FIG. 5 is a top plan view thereof;

FIG. 6 is a bottom plan view thereof; and,

FIG. 7 is a top, front and left side perspective view thereof with the wings shown in a folded position.

1 Claim, 6 Drawing Sheets

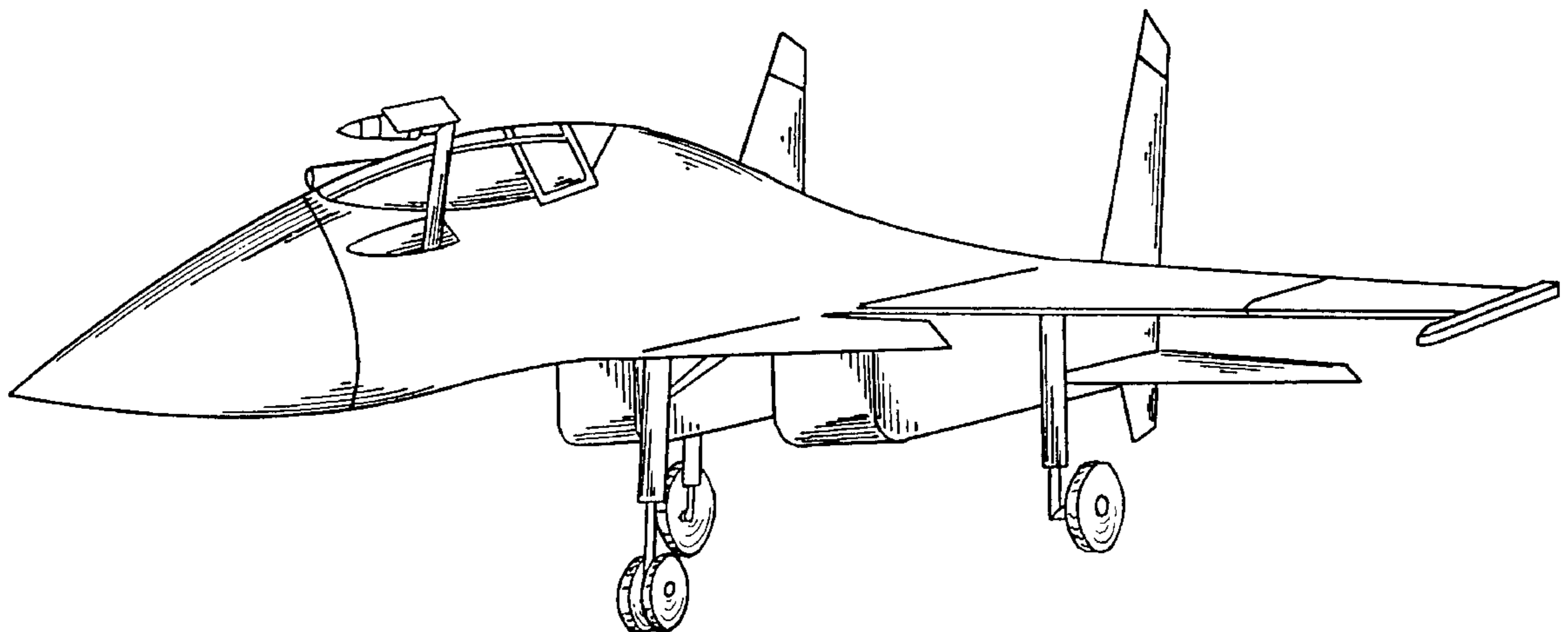

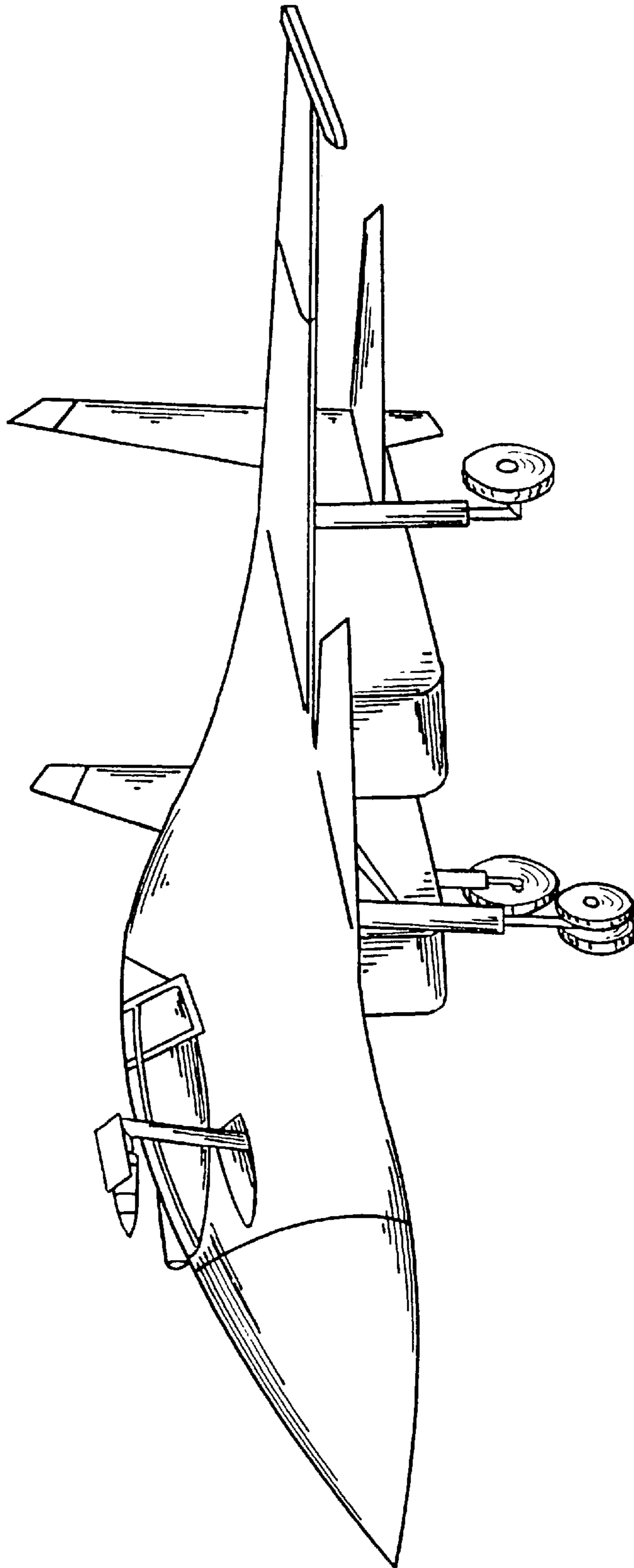

FIG. 1

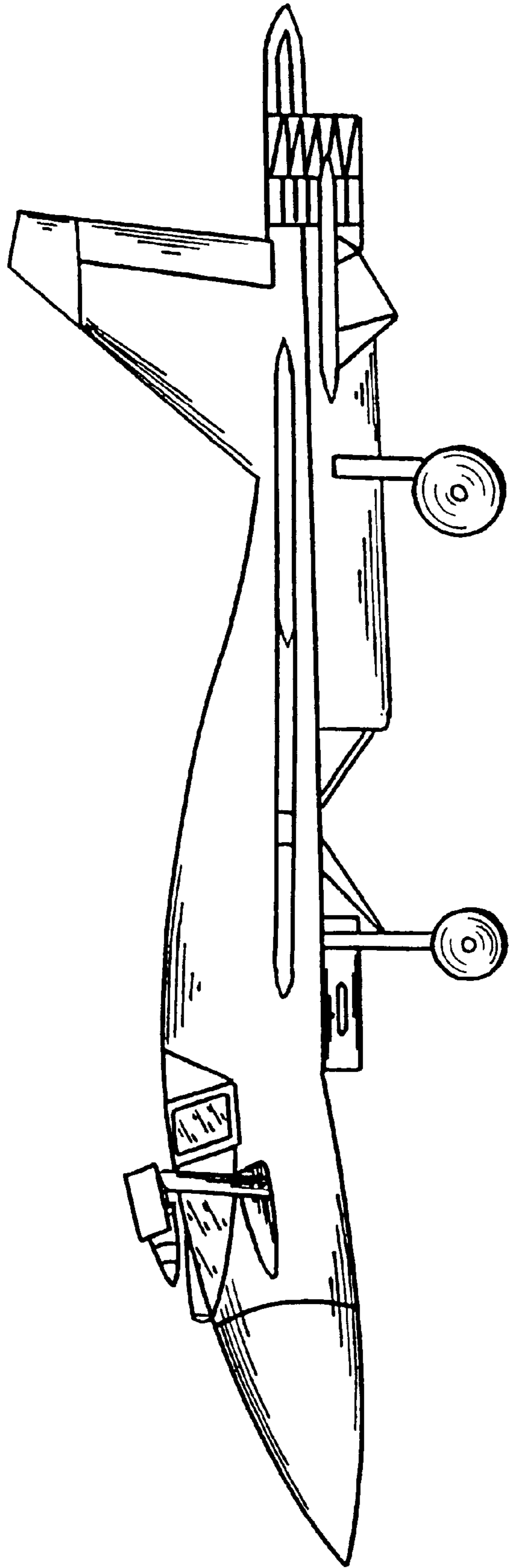

FIG.2

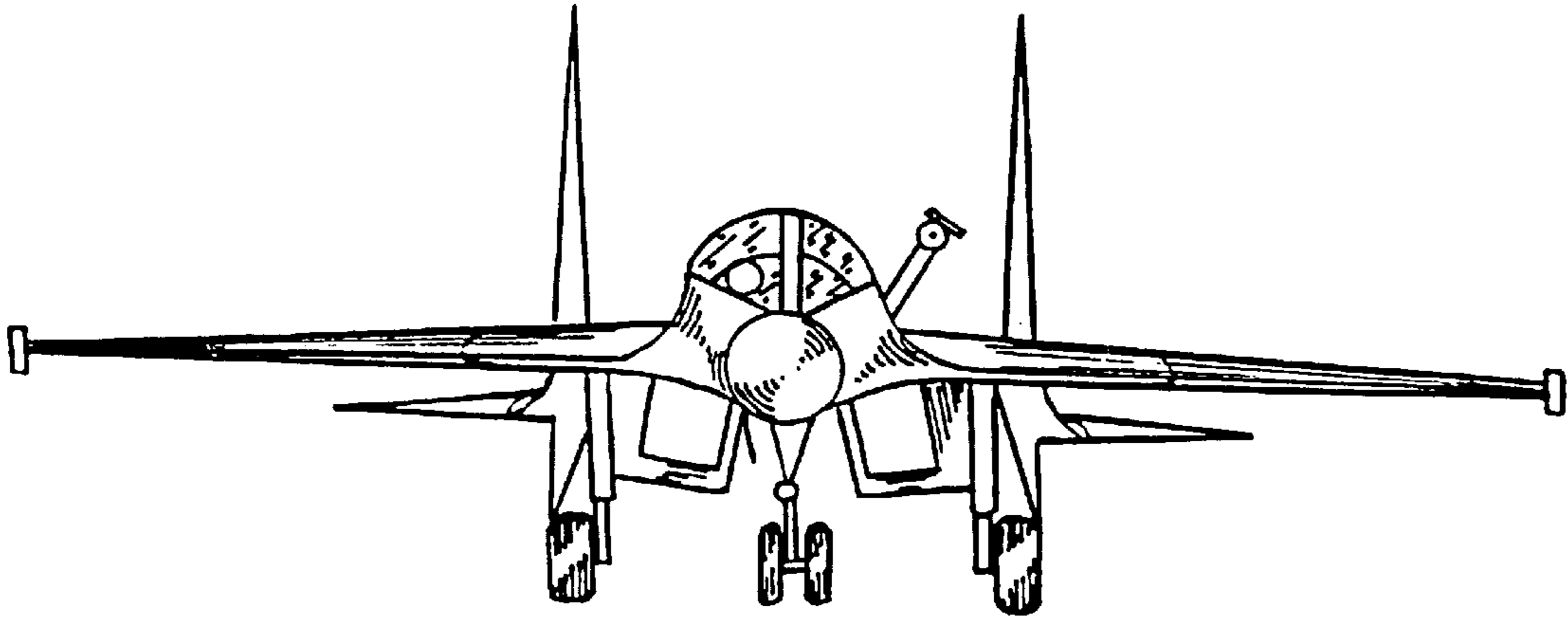

FIG.3

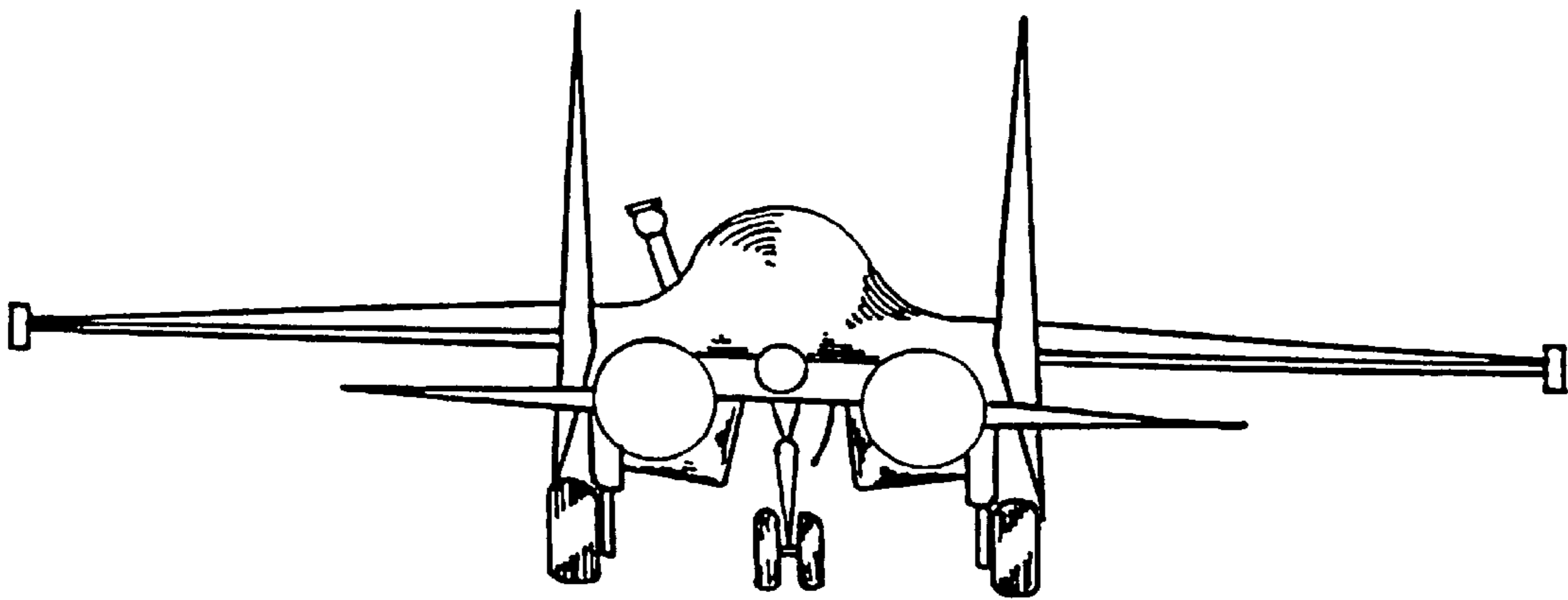

FIG.4

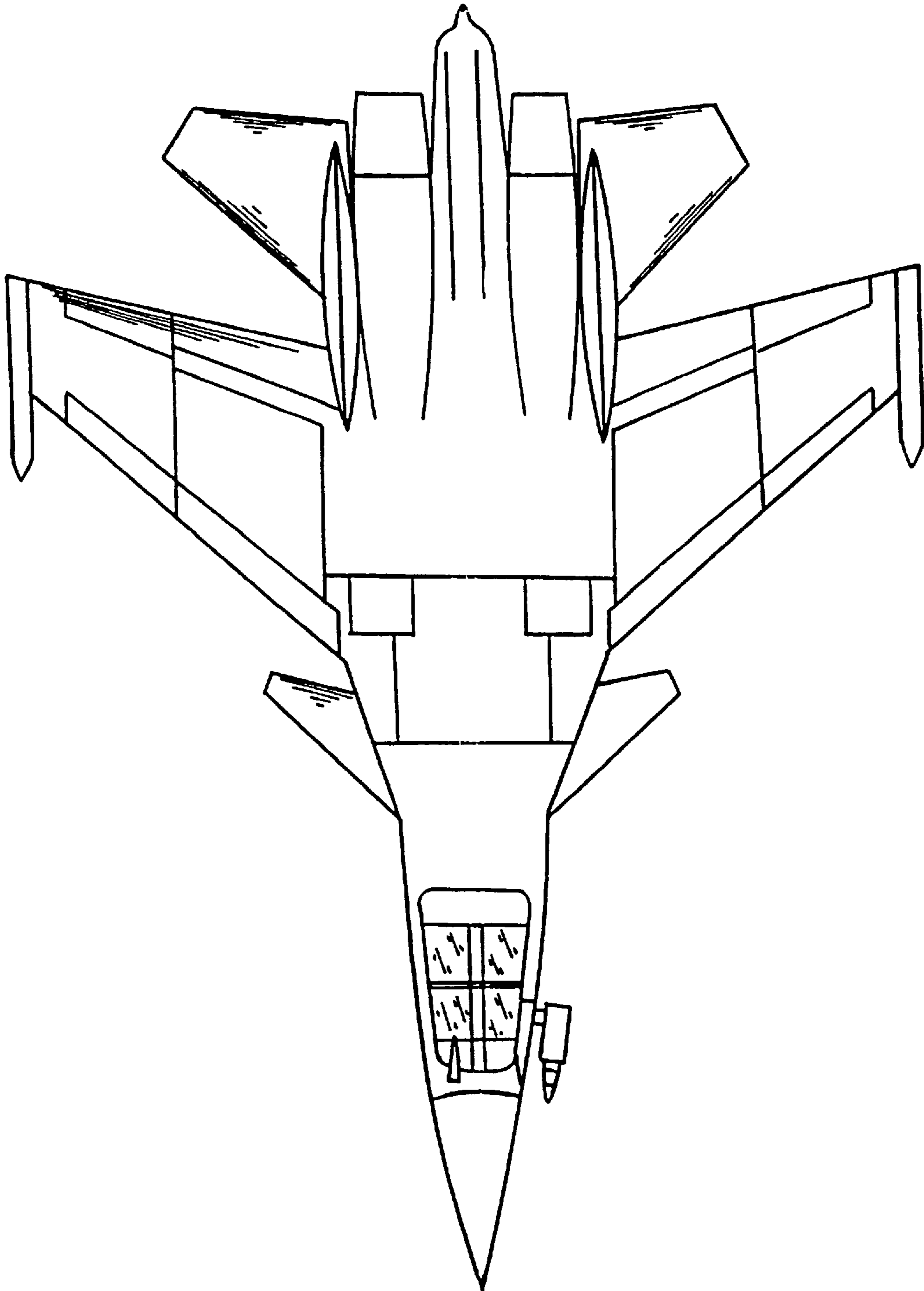

FIG. 5

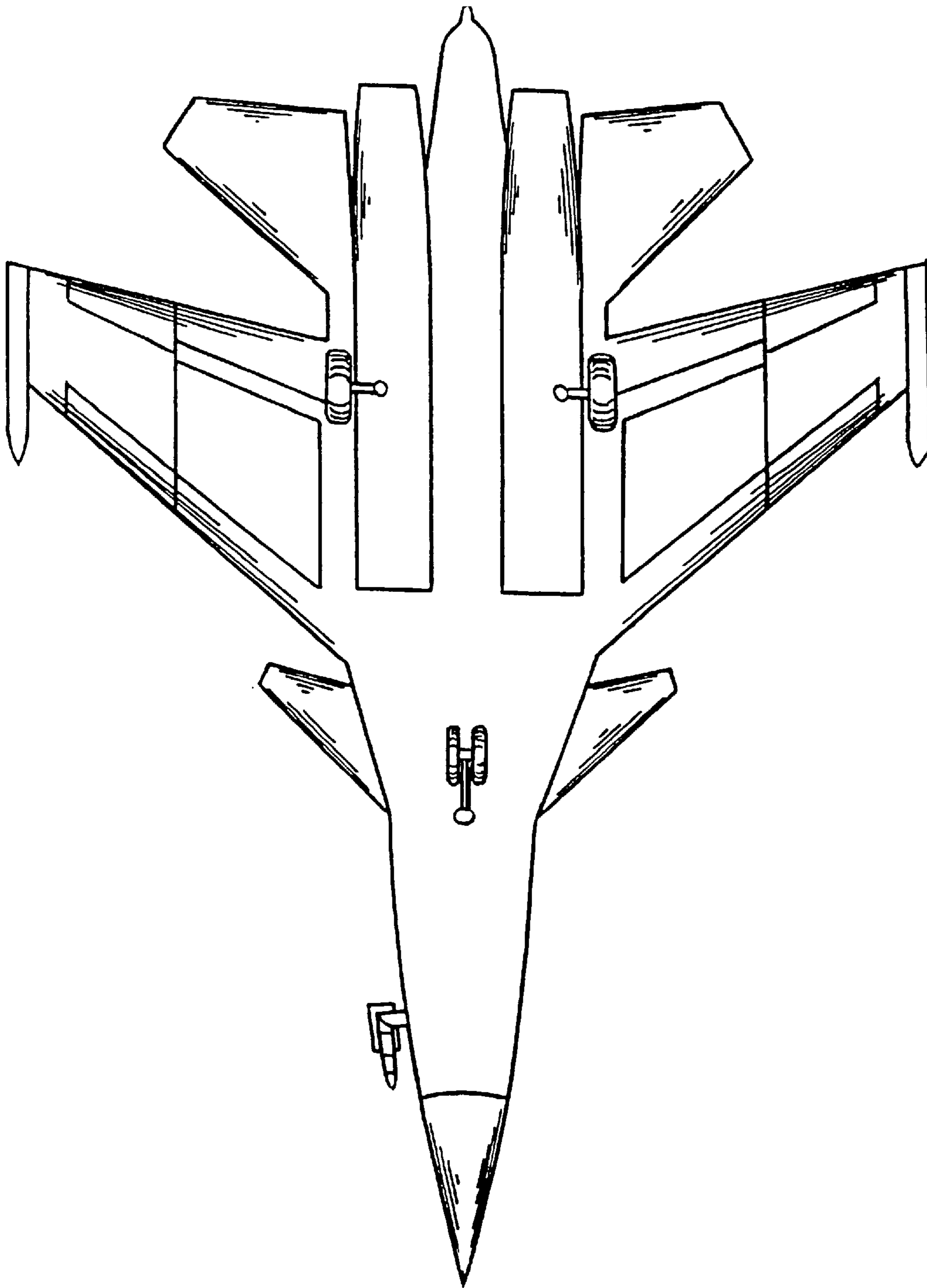

FIG. 6

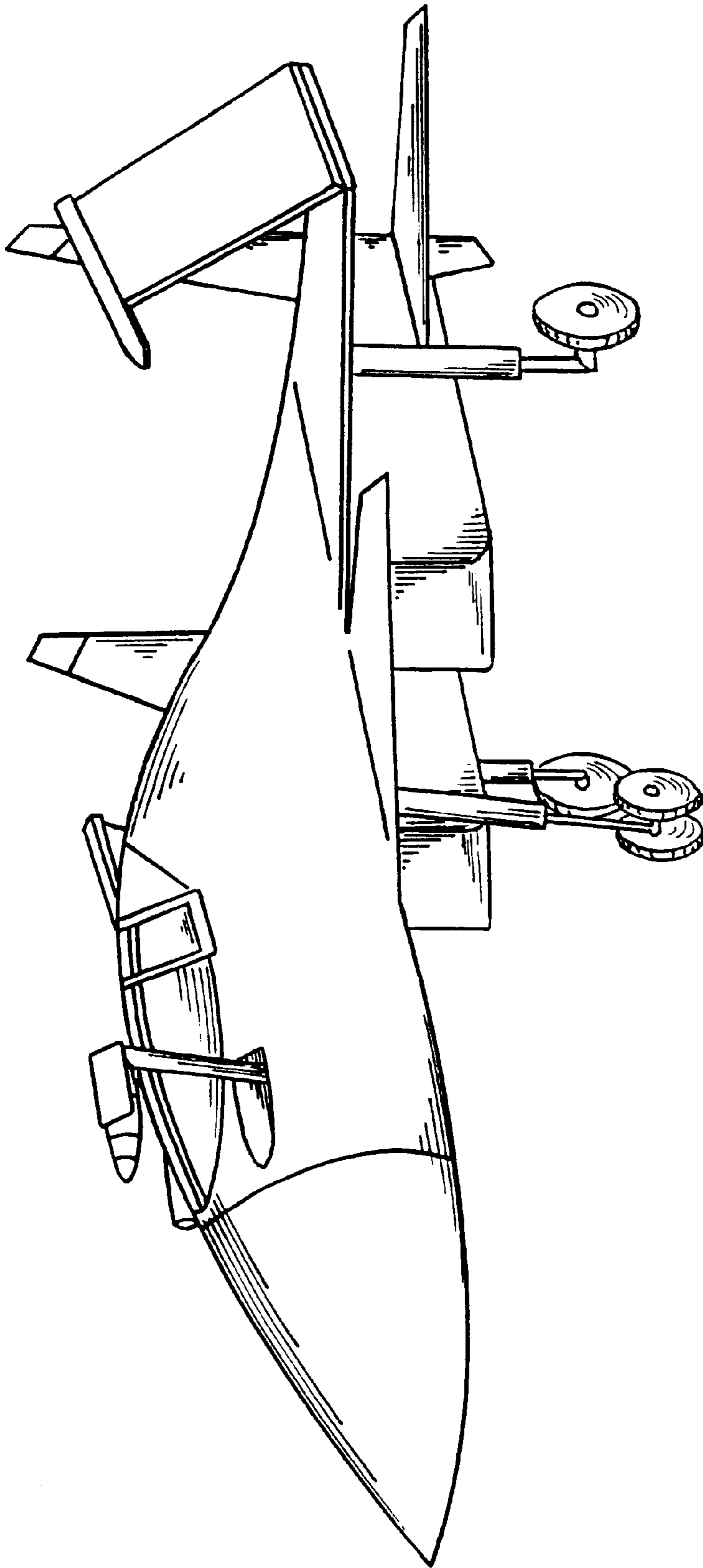

FIG. 7