



US00D439718S

(12) **United States Design Patent**
Thorpe

(10) **Patent No.:** **US D439,718 S**

(45) **Date of Patent:** **** Mar. 27, 2001**

(54) **REMOVABLE LEAF AND TRASH GUIDE**

(75) **Inventor:** **James C. Thorpe**, Fresno, CA (US)

(73) **Assignee:** **Liteweight Industries, LLC**, Fresno, CA (US)

(**) **Term:** **14 Years**

(21) **Appl. No.:** **29/115,021**

(22) **Filed:** **Dec. 6, 1999**

(51) **LOC (7) Cl.** **09-09**

(52) **U.S. Cl.** **D34/5; D34/28**

(58) **Field of Search** D34/1, 5, 6, 28,
D34/10; D23/200; 15/257.1, 257.4, 257.8,
257.9; D30/162; 220/908-911; 383/33,
34, 36; 248/95, 97, 99, 100, 101; D32/54;
222/570

(56) **References Cited**

U.S. PATENT DOCUMENTS

D. 161,852	*	2/1951	Meeder	D34/28
D. 236,938	*	9/1975	Bowen	D34/1
D. 238,151	*	12/1975	Shaffer	D32/54
D. 299,075	*	12/1988	Scott	D34/1
306,310	*	10/1884	Young	220/908
D. 308,270	*	5/1990	Sarabia	D34/5
D. 309,966	*	8/1990	Bishop	D34/5
D. 314,270	*	1/1991	Bryant	D34/28
D. 358,915	*	5/1995	O'Donoghue	D32/54
D. 389,971	*	1/1998	Zickenberg	D34/5
D. 391,717	*	3/1998	Stein	D32/54

434,514	*	8/1890	Lamb	220/908
1,923,816	*	8/1933	Firl	248/95
3,400,867	*	9/1968	Giannone	248/100
3,899,107	*	8/1975	Gaal	248/95
4,659,045	*	4/1987	Flynn	248/99
4,664,348	*	5/1987	Corsaut, III et al.	248/99
4,775,123	*	10/1988	Borland et al.	248/99
4,832,292	*	5/1989	Beckman	248/99
5,090,756	*	2/1992	Pfisterer	248/95
5,397,085	*	3/1995	Spagnolo	248/97
5,498,046	*	3/1996	Ridley, Sr. et al.	15/257.1
5,593,117	*	1/1997	Alexander, III	248/99

* cited by examiner

Primary Examiner—Cynthia E Ramirez

(74) *Attorney, Agent, or Firm*—Townsend and Townsend and Crew LLP

(57) **CLAIM**

The ornamental design for removable leaf and trash guide, as shown and described.

DESCRIPTION

FIG. 1 is a bottom, front, left perspective view of a showing my new design;

FIG. 2 is a top plan view showing inside surfaces thereof; FIG. 3 is a rear elevational view showing inside surfaces thereof;

FIG. 4 is a left side elevational view thereof, the right side view being a mirror image;

FIG. 5 is a front elevational view thereof; and,

FIG. 6 is a bottom plan view thereof.

1 Claim, 2 Drawing Sheets

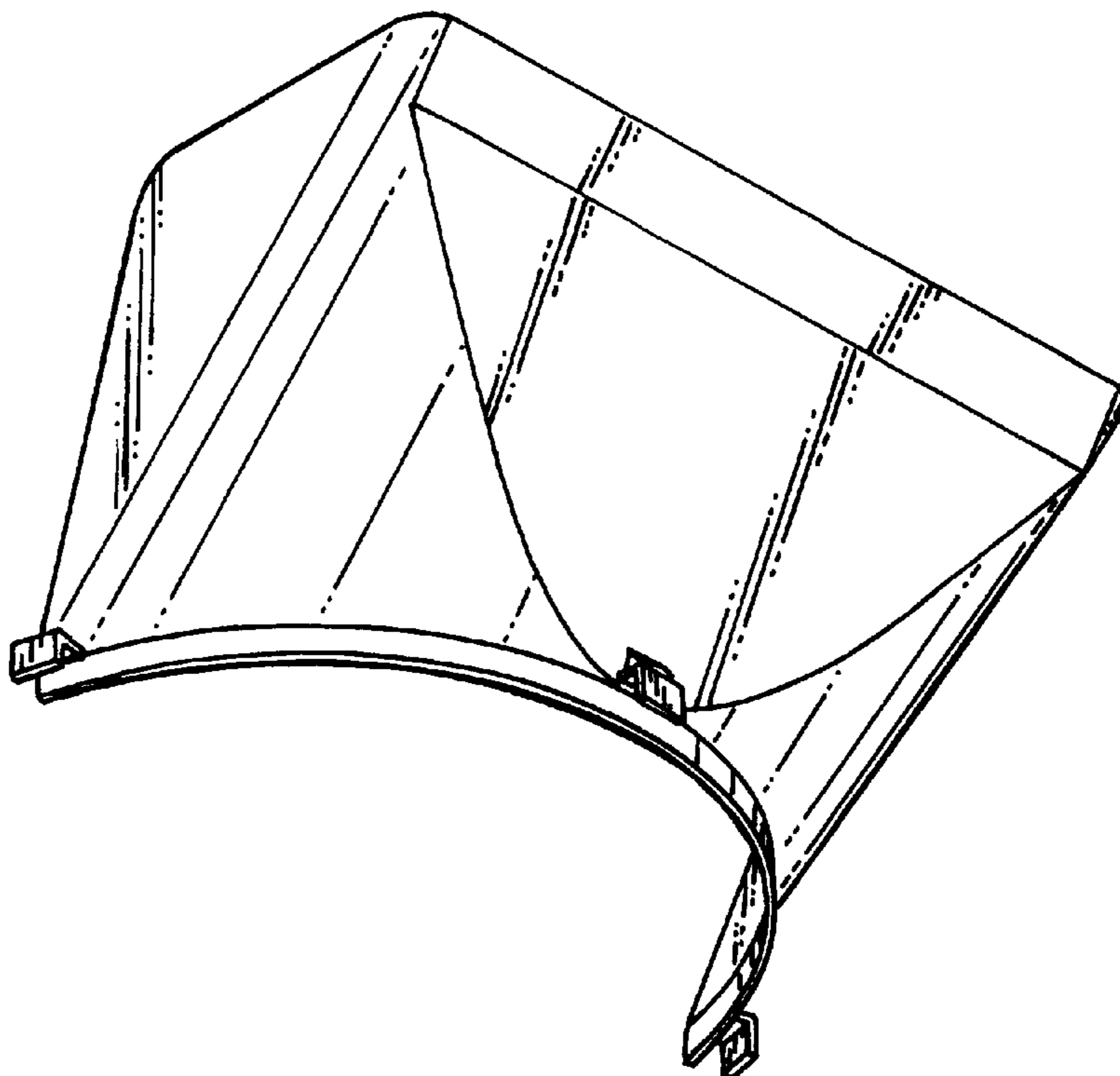

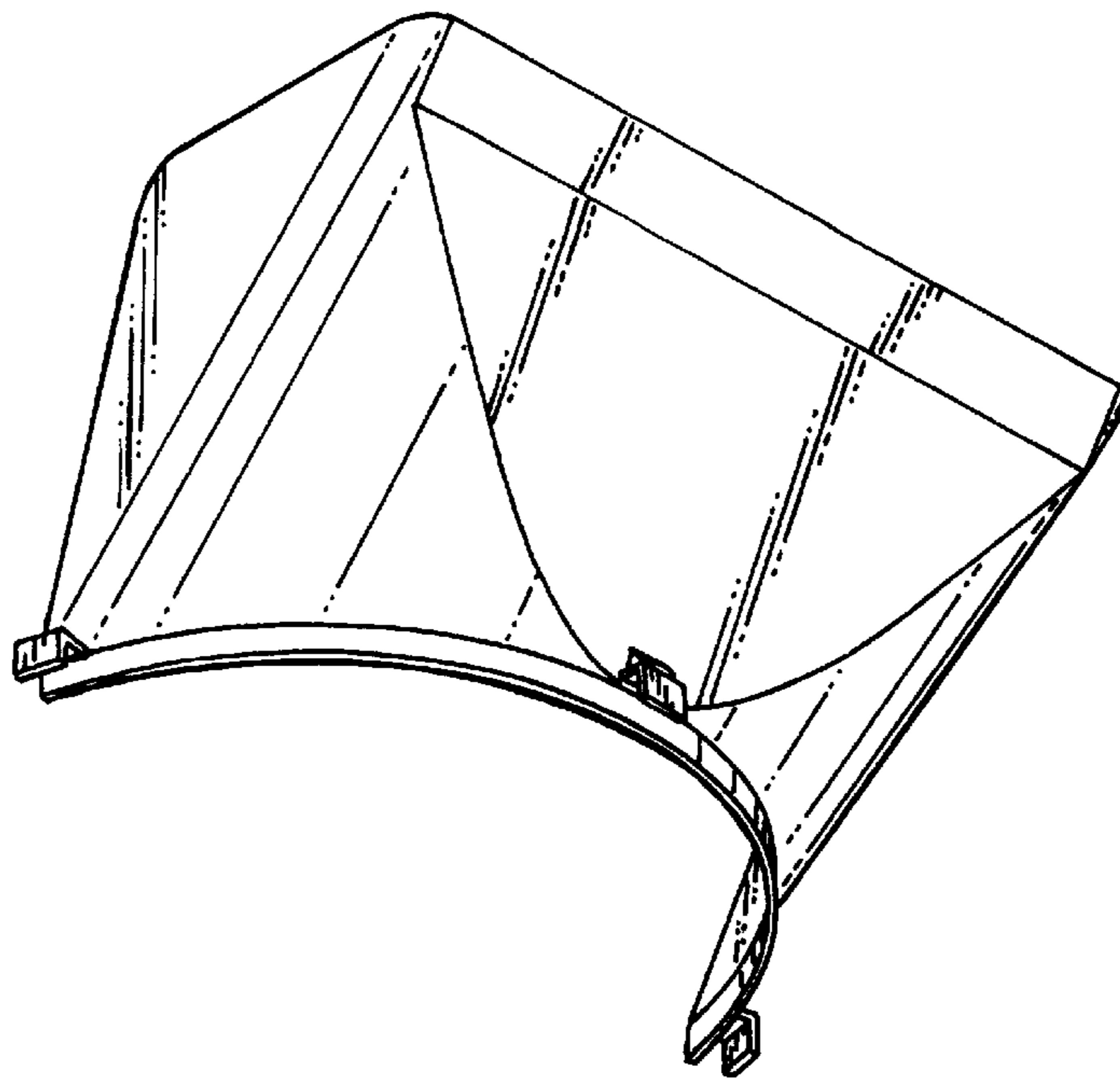

FIG. 1.

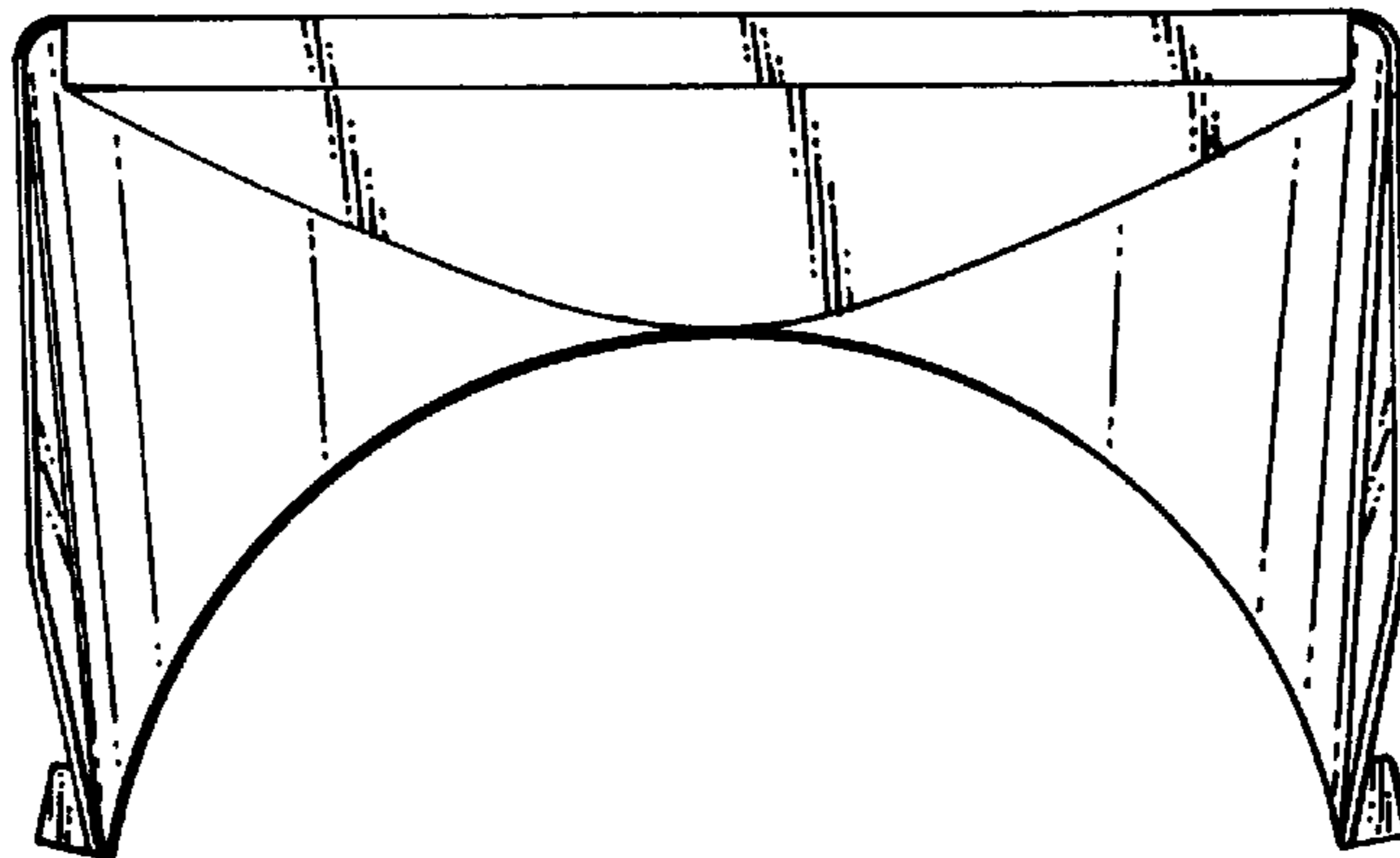

FIG. 2.

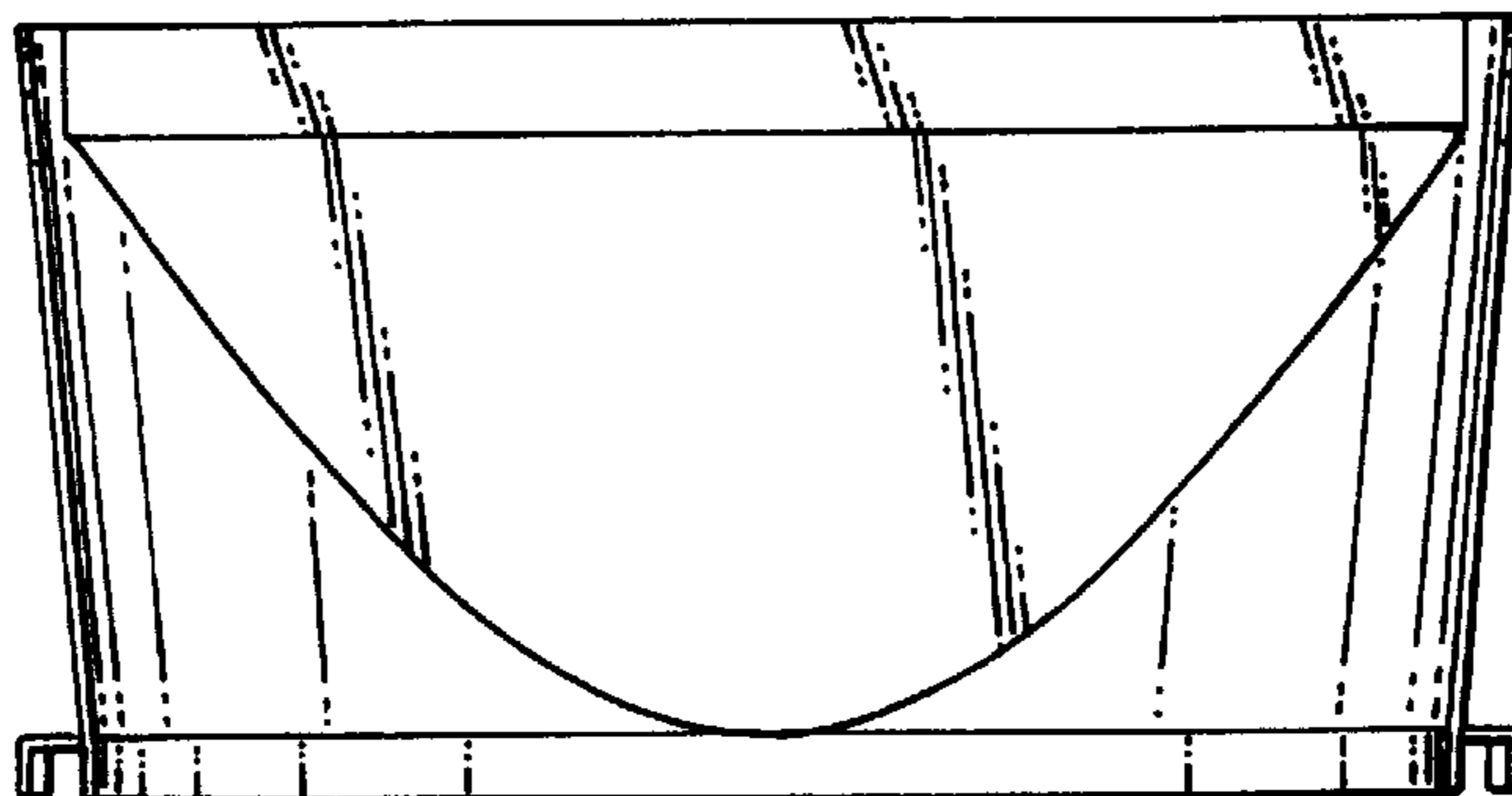

FIG. 3.

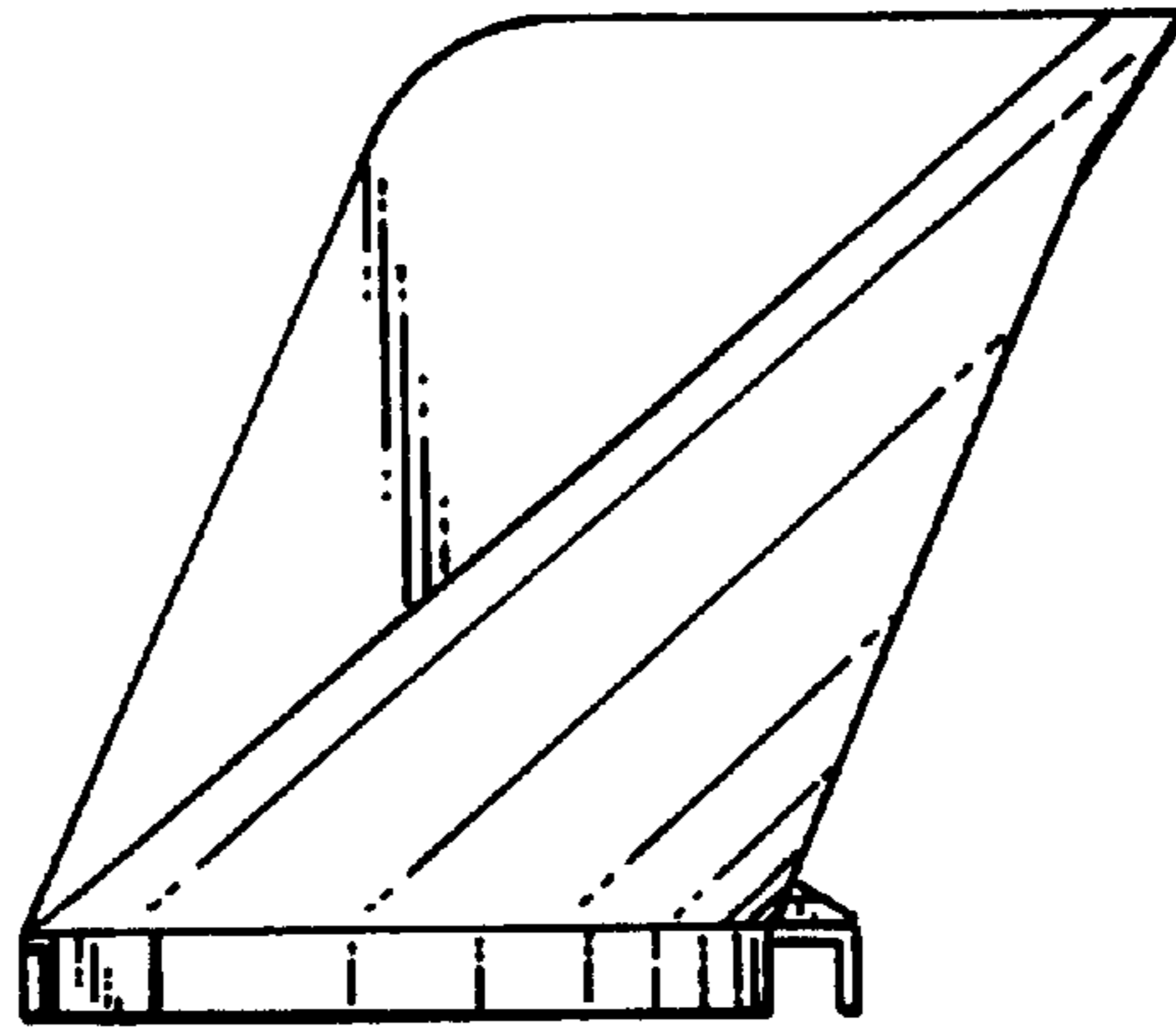

FIG. 4.

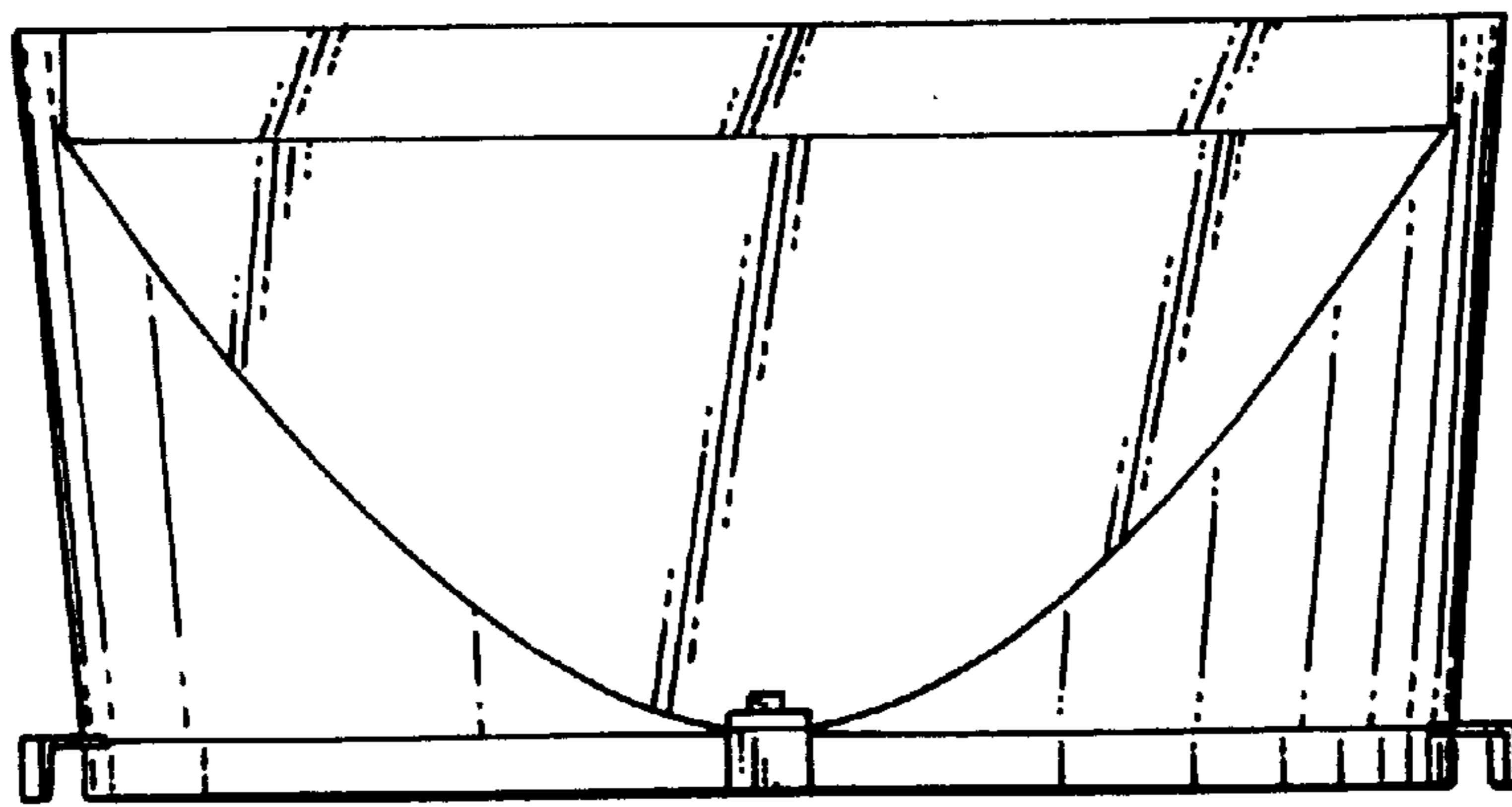

FIG. 5.

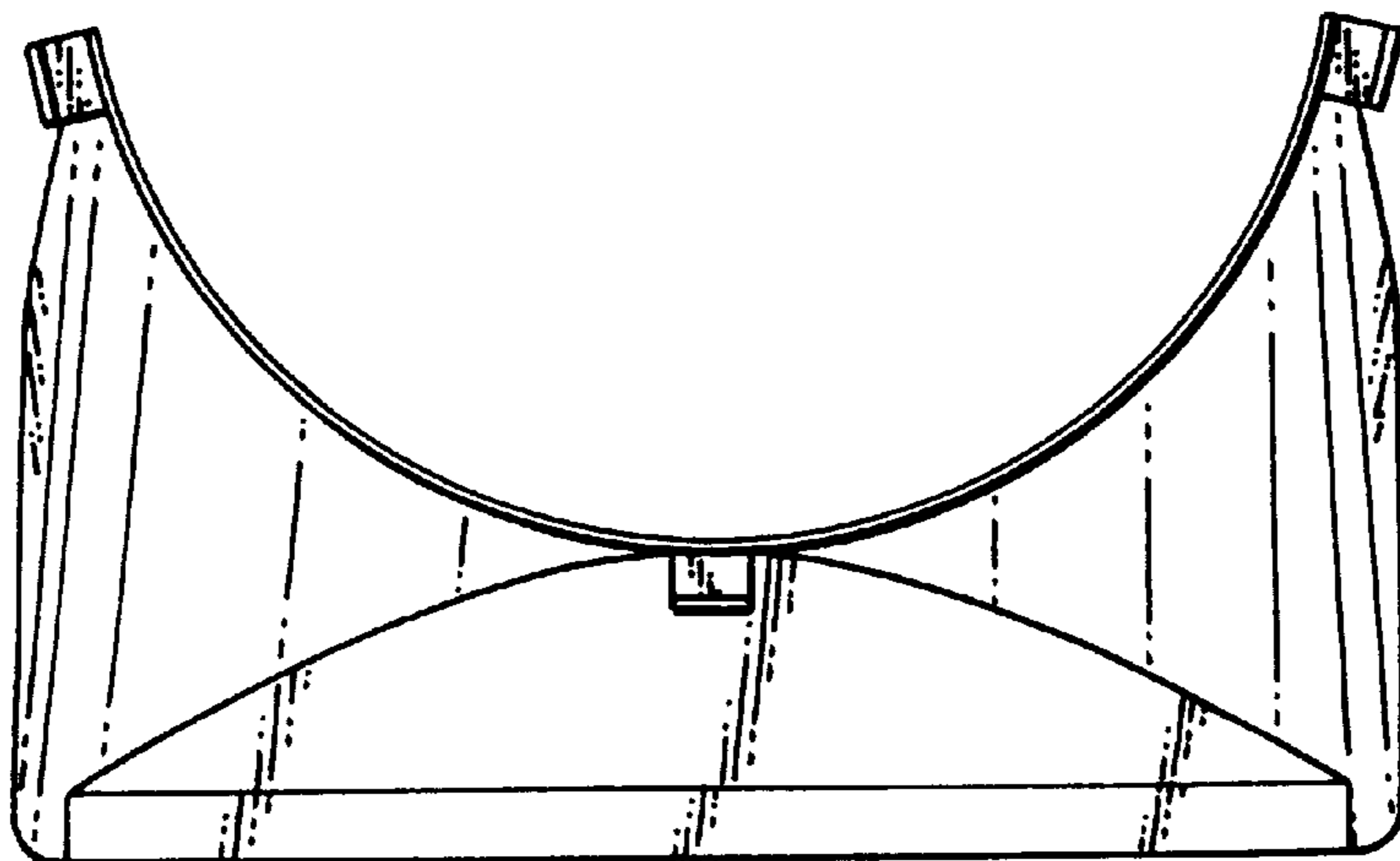

FIG. 6.