



US00D439550S

(12) **United States Design Patent**
Sacco et al.

(10) **Patent No.:** **US D439,550 S**

(45) **Date of Patent:** **** Mar. 27, 2001**

(54) **EXTERIOR SURFACE CONFIGURATION OF A VEHICLE**

(75) Inventors: **Bruno Sacco**, Sindelfingen; **Peter Pfeiffer**, Boeblingen, both of (DE)

(73) Assignee: **Daimler-Benz Aktiengesellschaft**, Stuttgart (DE)

(**) Term: **14 Years**

(21) Appl. No.: **29/086,738**

(22) Filed: **Apr. 20, 1998**

(51) **LOC (7) Cl.** **12-08**

(52) **U.S. Cl.** **D12/91**

(58) **Field of Search** D12/91, 90, 92;
296/185

(56) **References Cited**

U.S. PATENT DOCUMENTS

D. 372,689	*	8/1996	Sacco et al.	D12/92
D. 373,331	*	9/1996	Ohkura et al.	D12/91
D. 380,178	*	6/1997	Sacco et al.	D12/92
D. 393,610		4/1998	Sacco et al.	D12/92
D. 395,847	*	7/1998	Sacco	D12/92
D. 396,432	*	7/1998	Syring	D12/92

* cited by examiner

Primary Examiner—Melody N. Brown

(74) *Attorney, Agent, or Firm*—Evenson, McKeown, Edwards & Lenahan, PLLC

(57) **CLAIM**

The ornamental design for an exterior surface configuration of a vehicle, as shown and described.

DESCRIPTION

FIG. 1 is a front view of an exterior surface configuration of a vehicle according to our novel design;

FIG. 2 is a perspective view from the front left of an exterior surface configuration of a vehicle according to our novel design;

FIG. 3 is a perspective view from the front right of an exterior surface configuration of a vehicle according to our novel design;

FIG. 4 is a left side view of an exterior surface configuration of a vehicle according to our novel design;

FIG. 5 is a right side view of an exterior surface configuration of a vehicle according to our novel design;

FIG. 6 is a perspective view from the rear left of an exterior surface configuration of a vehicle according to our novel design;

FIG. 7 is a perspective view from the rear right of an exterior surface configuration of a vehicle according to our novel design;

FIG. 8 is a rear view of an exterior surface configuration of a vehicle according to our novel design; and,

FIG. 9 is a top view of an exterior surface configuration of a vehicle according to our novel design;

The broken lines shown in all drawing views are for illustrative purposes only and form no part of the claimed design.

1 Claim, 8 Drawing Sheets

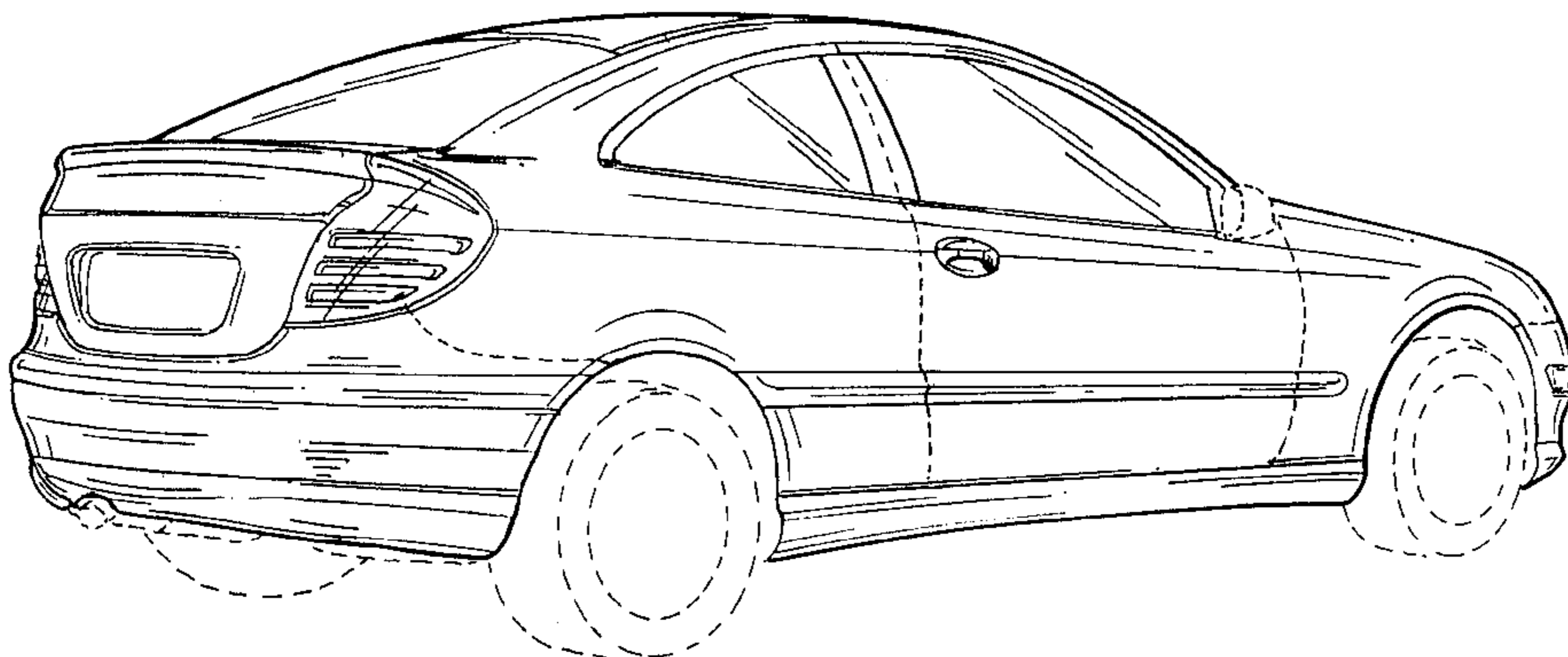
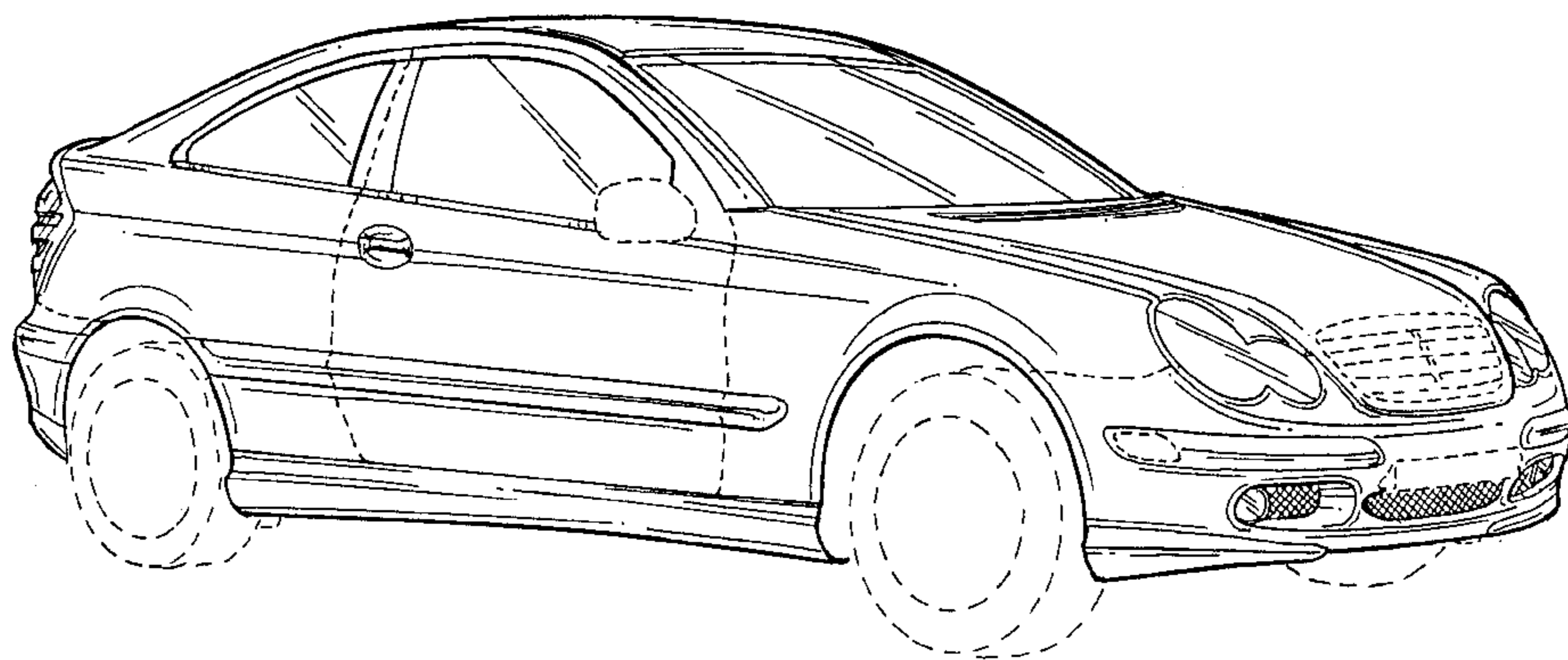

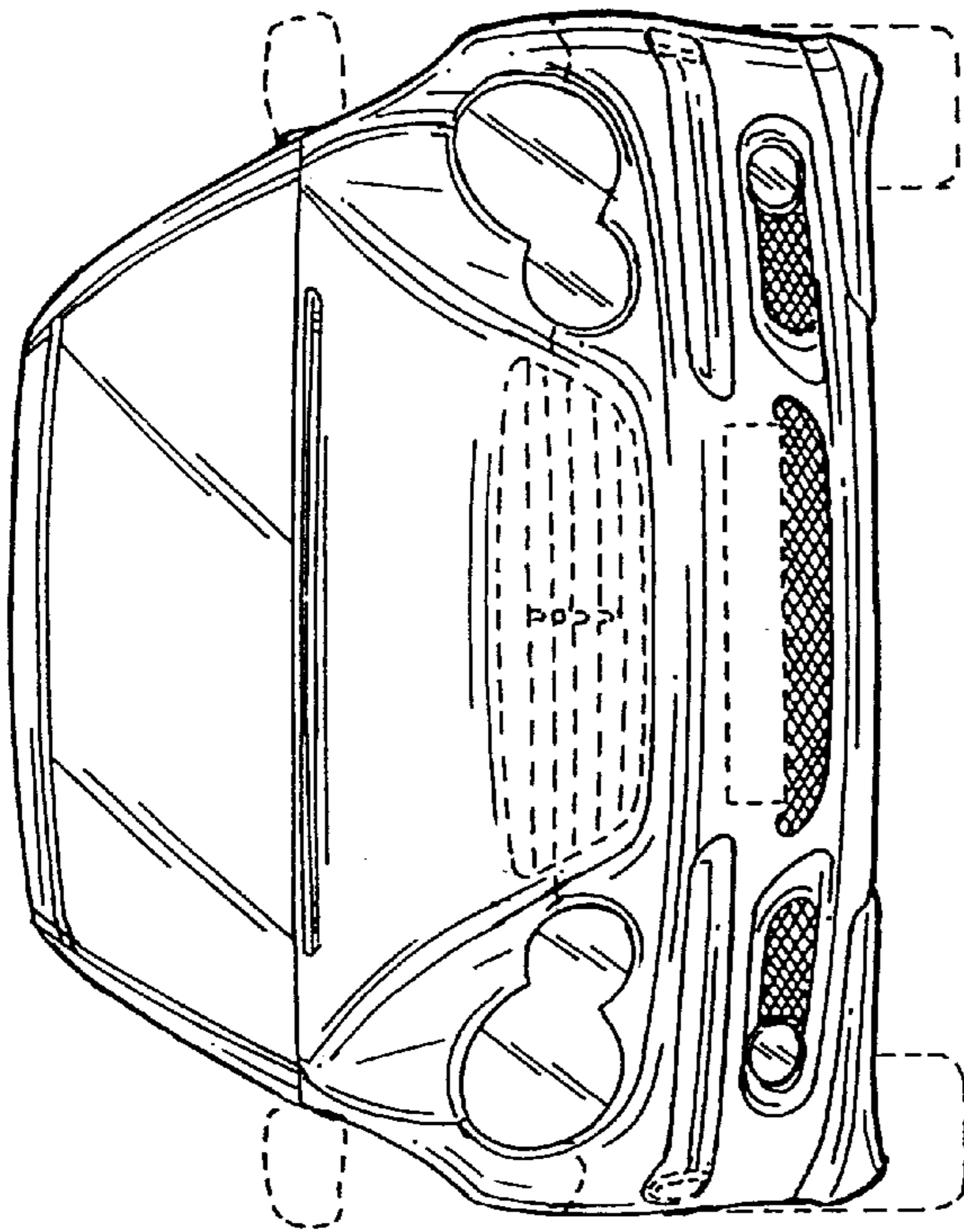

FIG. 1

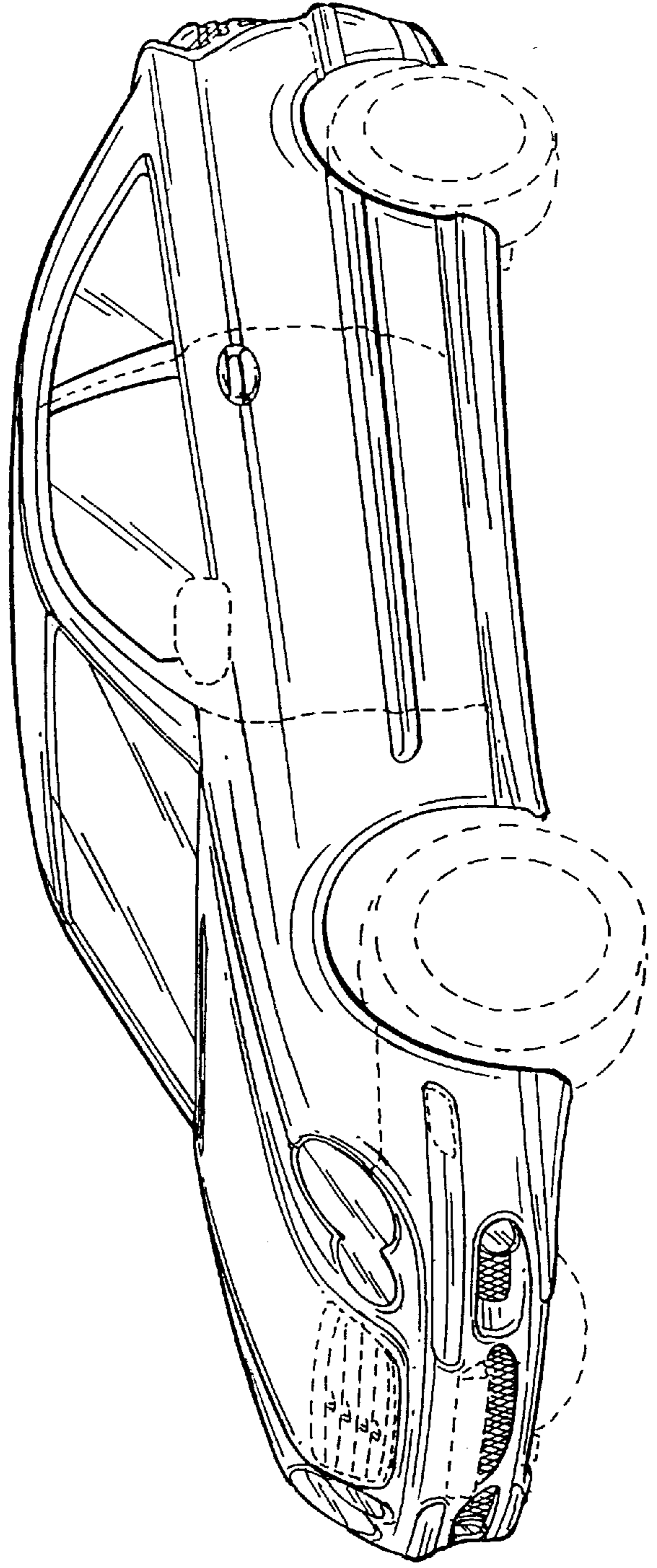

FIG. 2

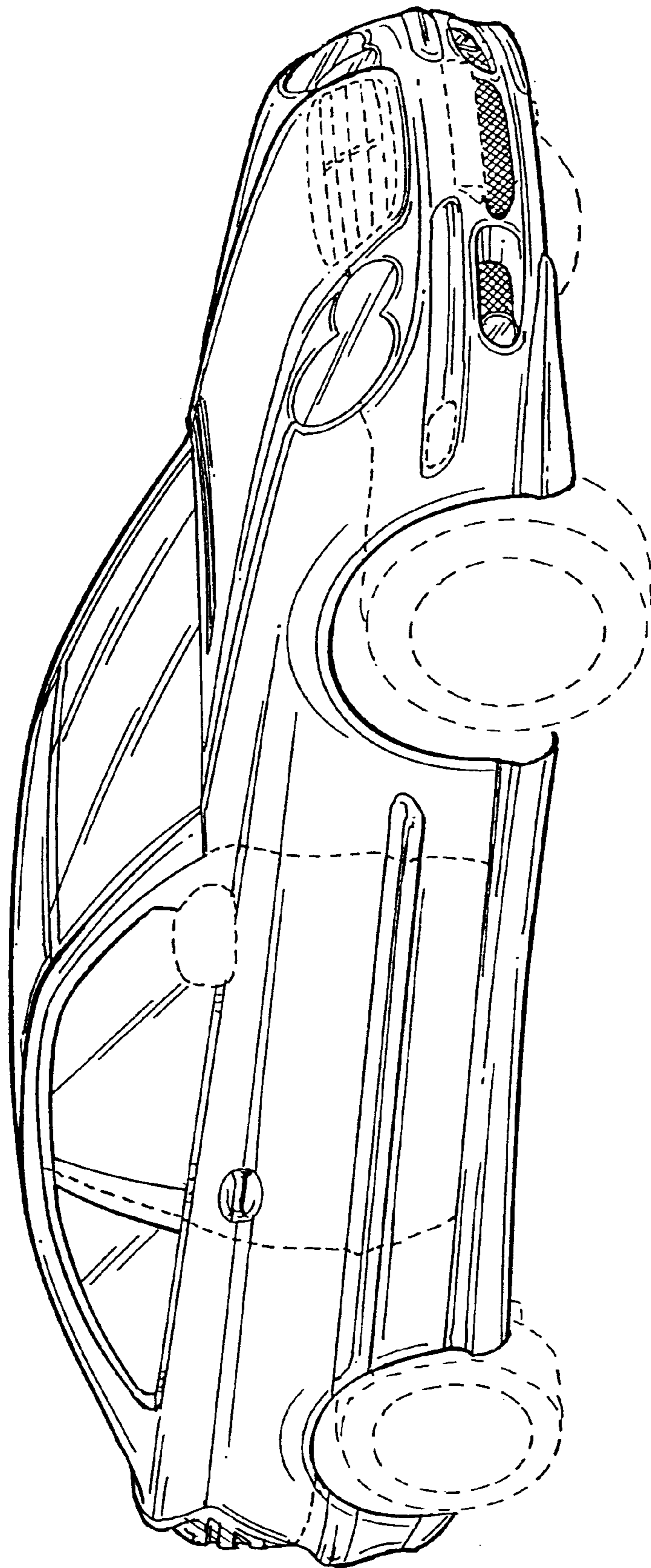

FIG. 3

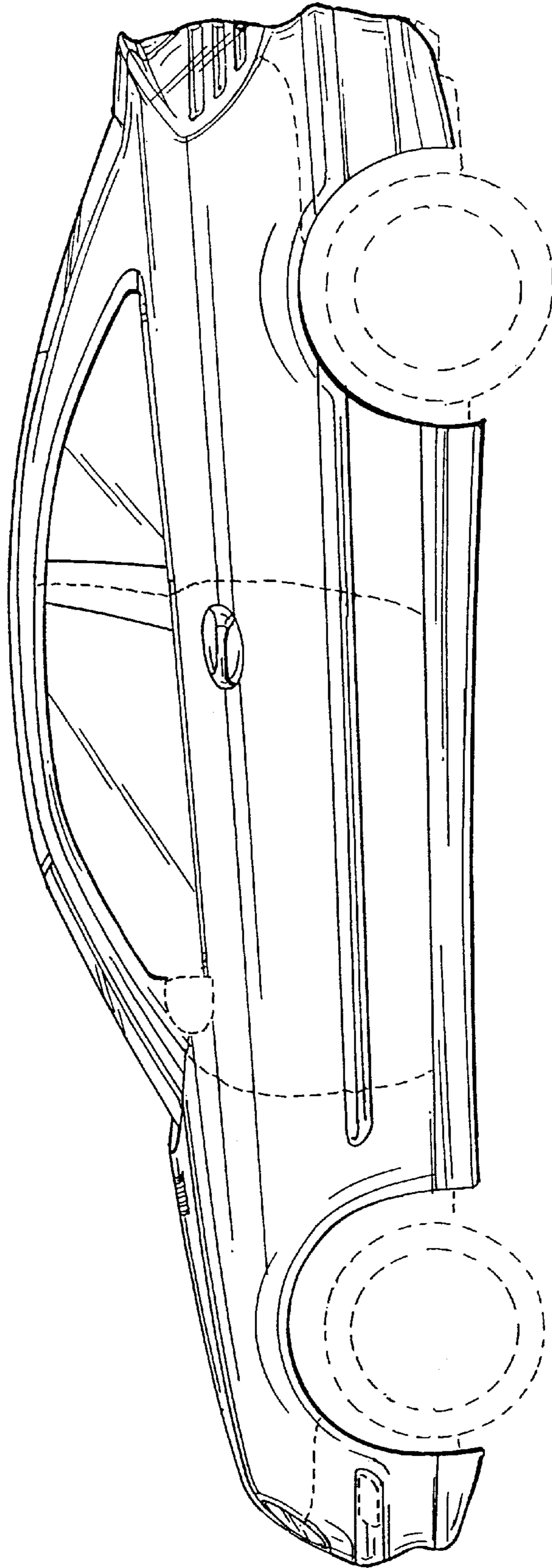

FIG. 4

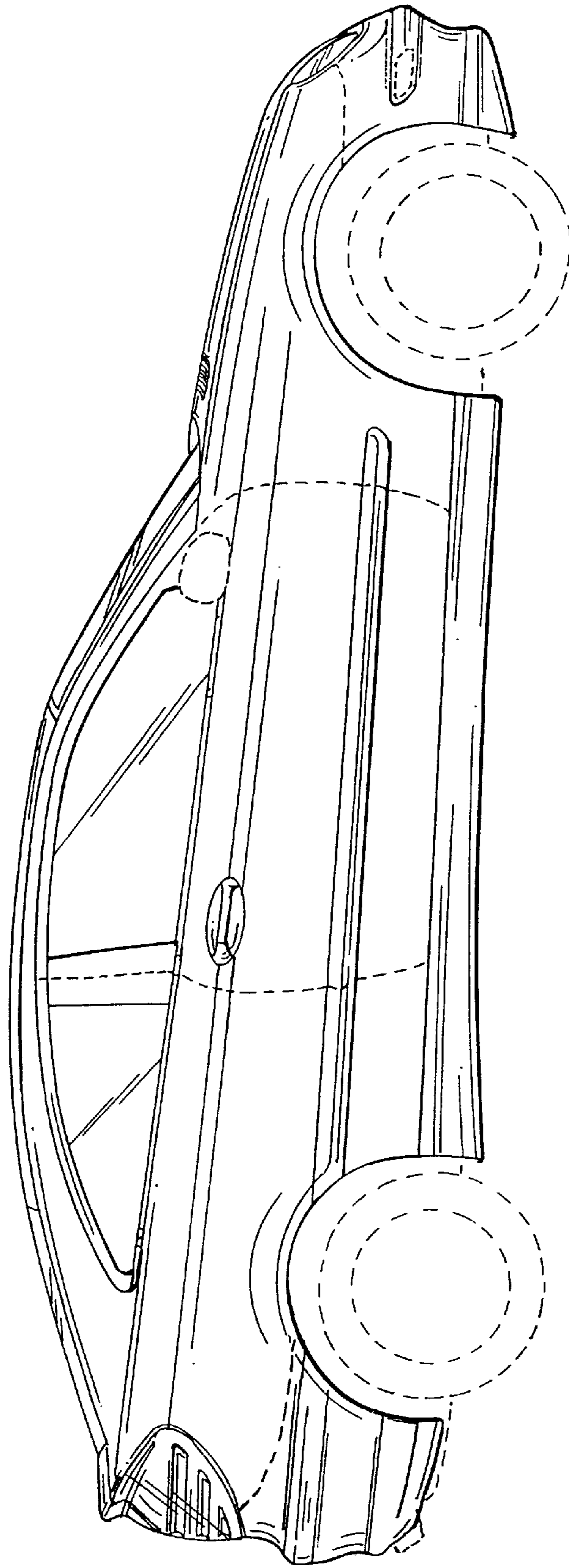

FIG. 5

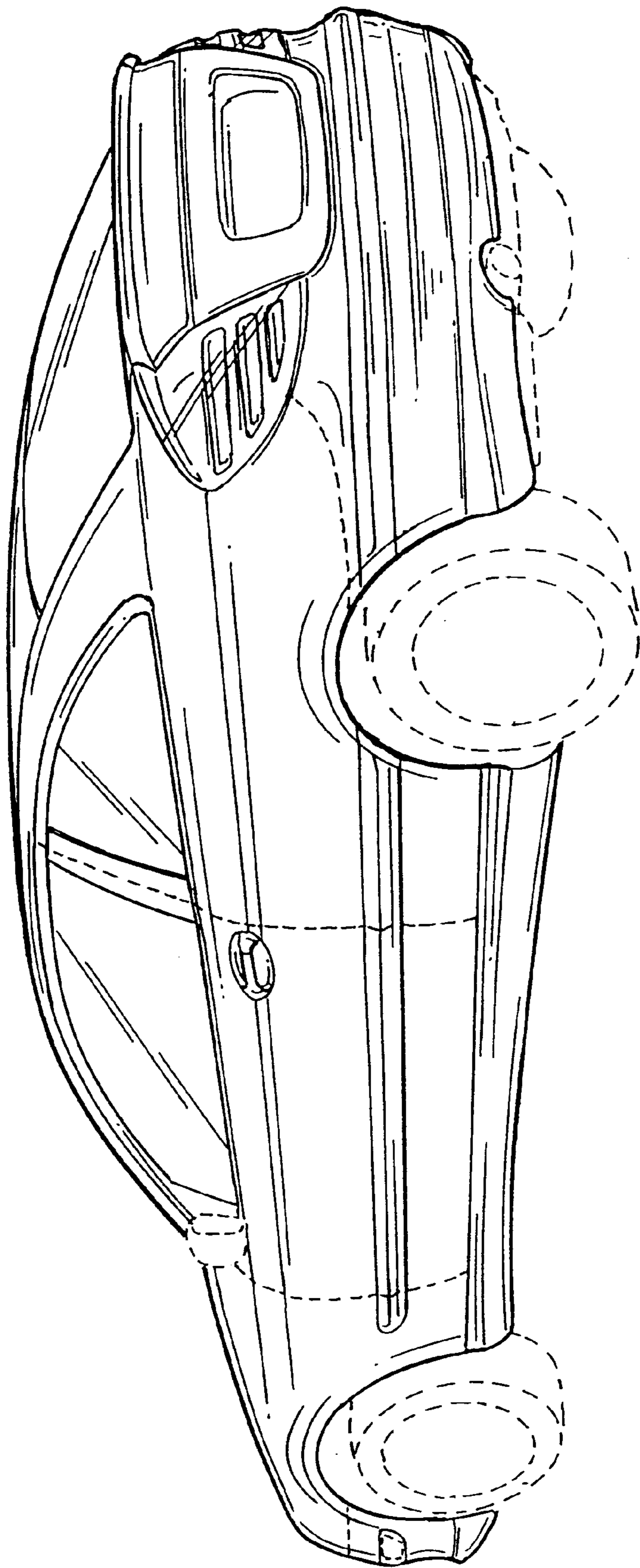

FIG. 6

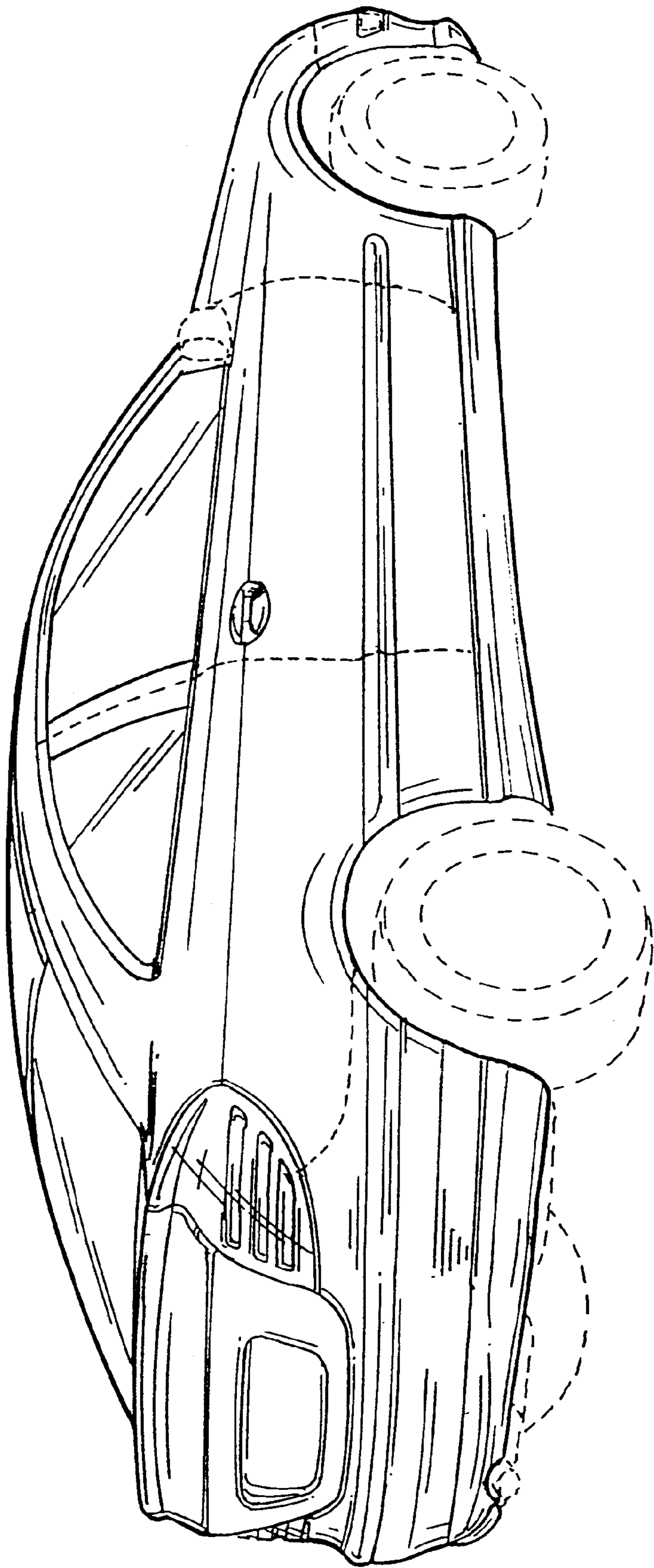

FIG. 7

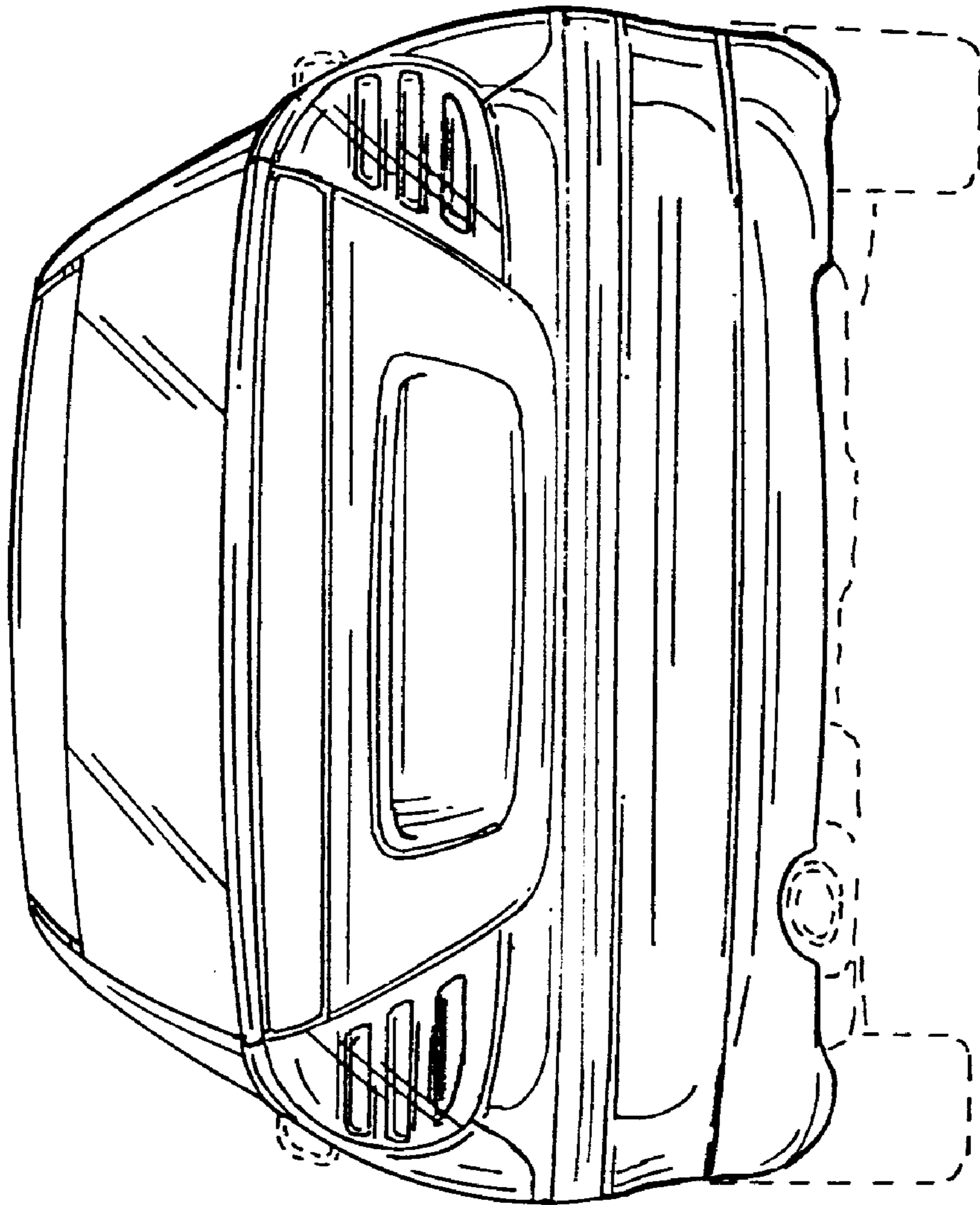

FIG. 8

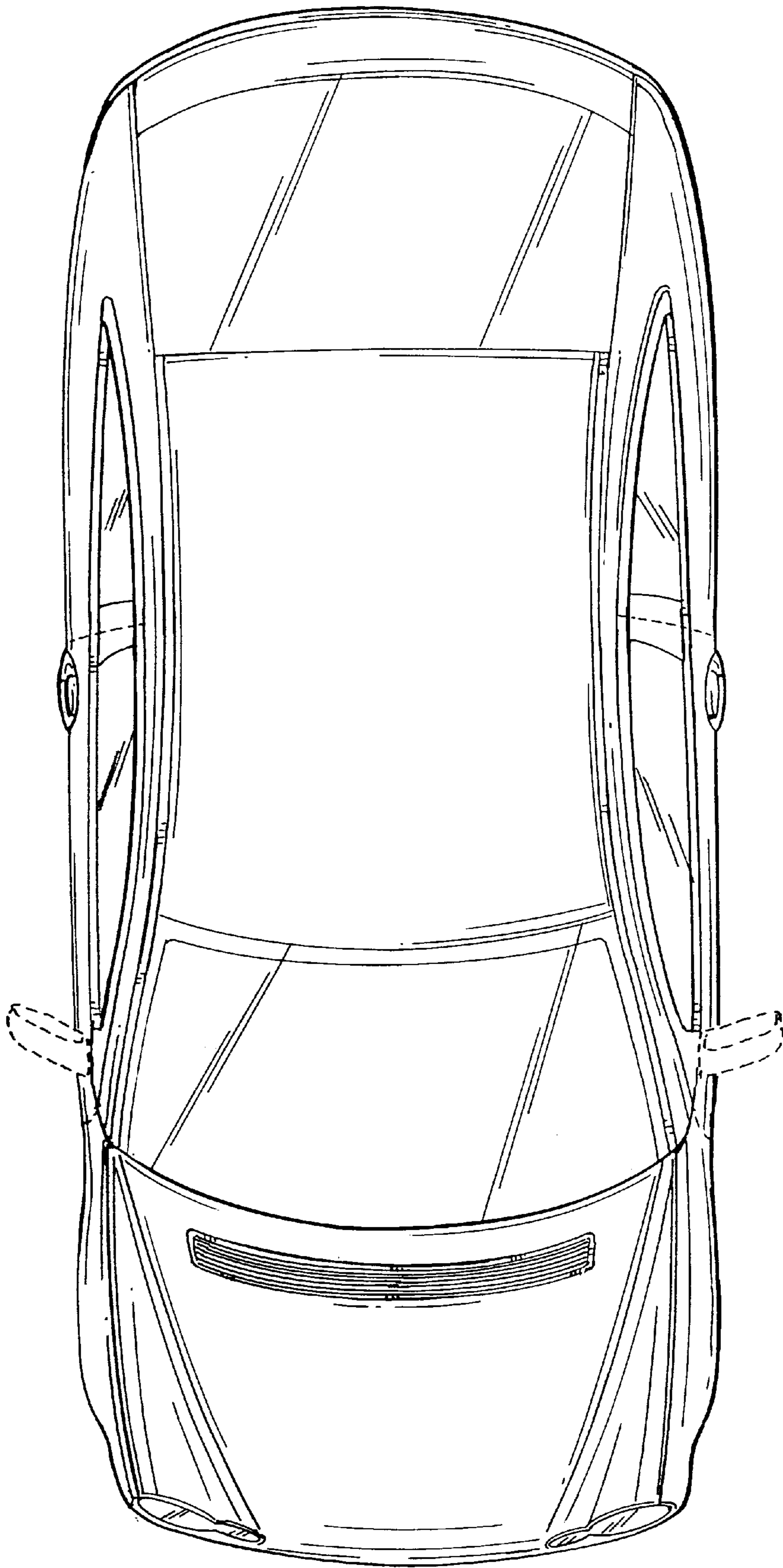

FIG. 9