



US00D439549S

(12) **United States Design Patent**
Shambeau et al.

(10) **Patent No.:** **US D439,549 S**

(45) **Date of Patent:** **** Mar. 27, 2001**

(54) **UTILITY VEHICLE BODY**

(75) Inventors: **Thomas Allan Shambeau; Nicholas Hamm**, both of Beaver Dam, WI (US); **Loren Fredrick Hansen**, Lincoln, NE (US); **Eugene Bertrum Glaze**, Aurora (CA)

(73) Assignee: **Deere & Company**, Moline, IL (US)

(**) Term: **14 Years**

(21) Appl. No.: **29/121,880**

(22) Filed: **Apr. 14, 2000**

(51) **LOC (7) Cl.** **12-13**

(52) **U.S. Cl.** **D12/14**

(58) **Field of Search** D12/14, 1, 15,
D12/96-99; 296/183, 190.01, 181; 180/311,
234

(56) **References Cited**

U.S. PATENT DOCUMENTS

D. 254,431	3/1980	Broyhill et al.	D12/97
D. 301,128	5/1989	Simon	D12/15
D. 305,519	1/1990	Crookes et al.	D12/5
D. 310,342	* 9/1990	Formoso	D12/14
D. 311,505	* 10/1990	Reinhart	D12/14
D. 337,747	7/1993	Hinklin et al.	D12/15
D. 364,590	11/1995	Yamashita	D12/15
D. 425,446	* 5/2000	Schnell	D12/14
5,509,710	4/1996	Eavenson, Sr. et al.	296/19

OTHER PUBLICATIONS

John Deere, 1800 Utility Vehicle brochure, 3 pages, published Jan. 1998 in U.S.A.

John Deere, Military Gator Utility Vehicle brochure, 2 pages, published Mar. 1998 in U.S.A.

John Deere, Gator Utility Vehicles brochure, 8 pages, published Jan. 1998 in U.S.A.

Daihatsu America, Inc., Hijet Multipurpose Off-Road Utility Vehicle Daihatsu, 6 pages, publication date and country unknown.

* cited by examiner

Primary Examiner—Melody N. Brown

(57) **CLAIM**

The ornamental design for a utility vehicle body, as shown and described.

DESCRIPTION

FIG. 1 is a left front elevated perspective view of a utility vehicle body showing our new design, the broken line showing the vehicle being for illustrative purposes only, and forming no part of the claimed design;

FIG. 2 is a plan view of the utility vehicle body design of FIG. 1;

FIG. 3 is a left side view thereof;

FIG. 4 is a right side view thereof;

FIG. 5 is a front view thereof; and,

FIG. 6 is a rear view thereof.

1 Claim, 6 Drawing Sheets

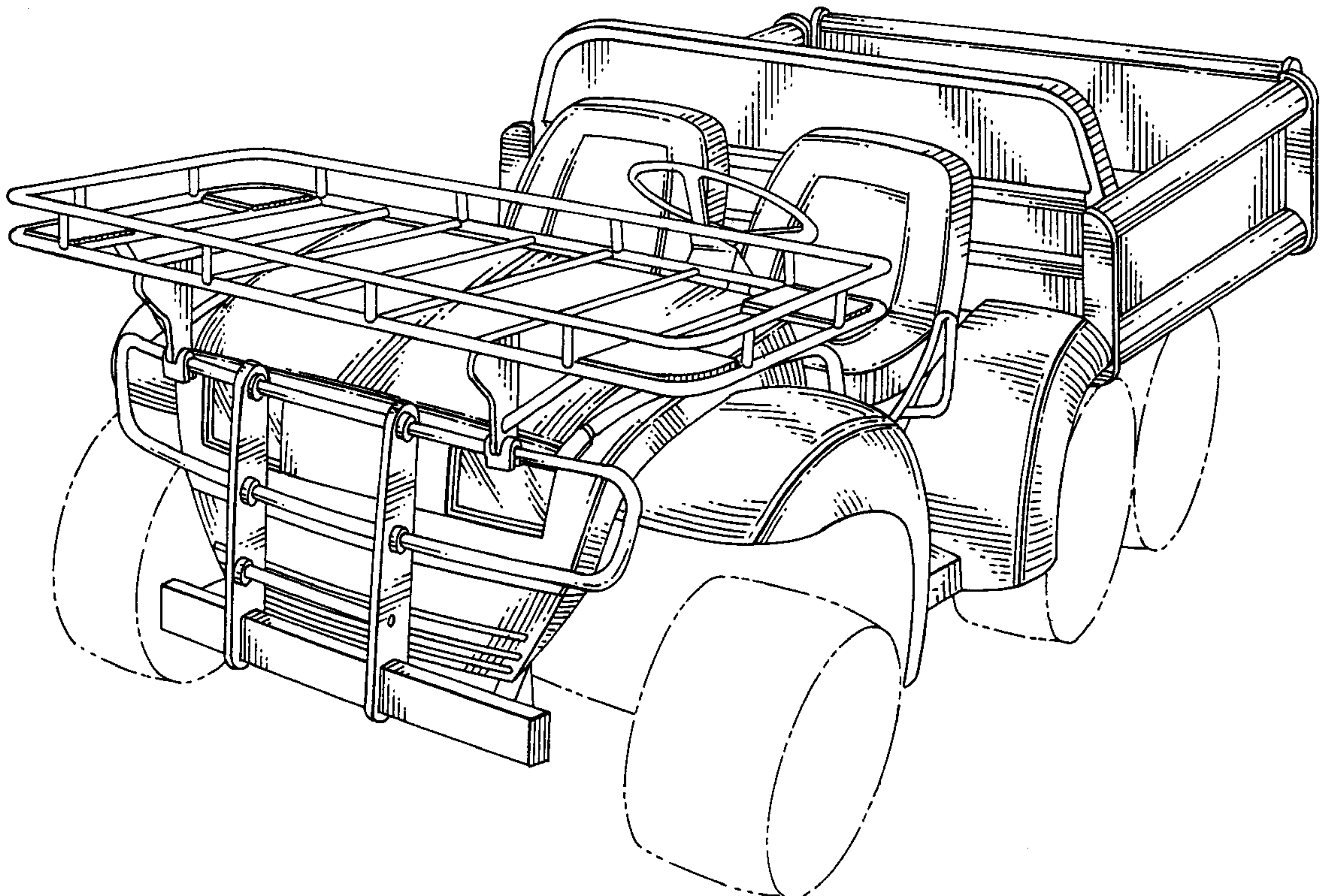

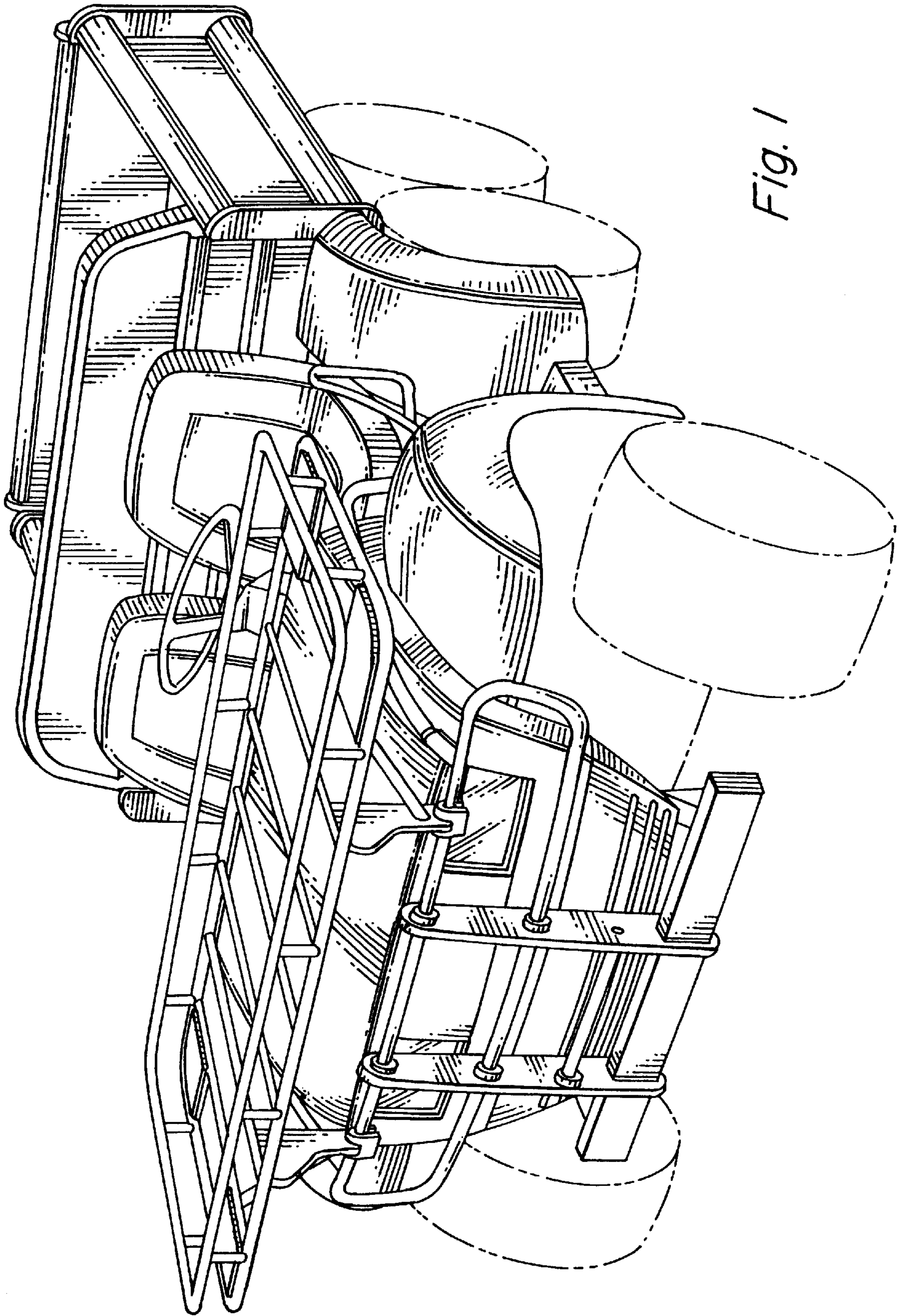

Fig. 1

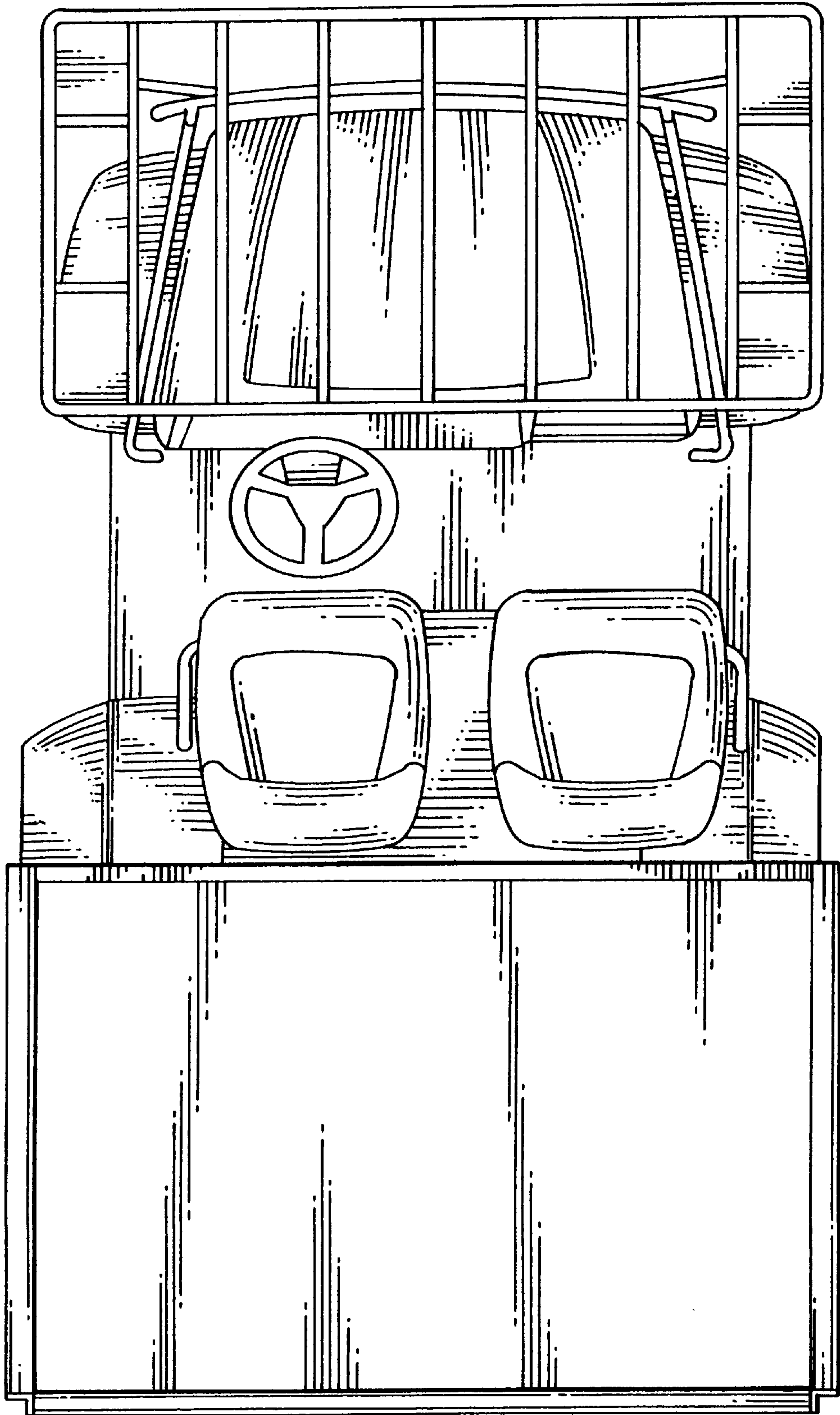

Fig. 2

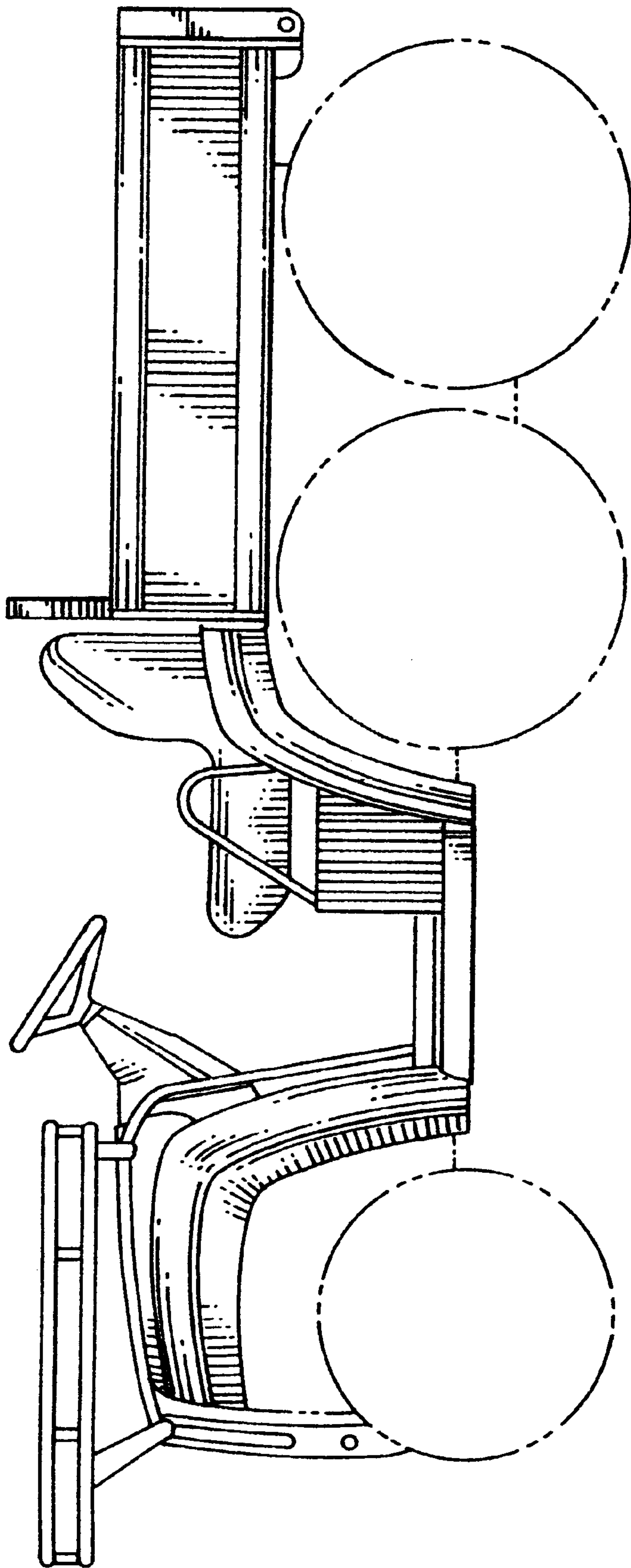

Fig. 3

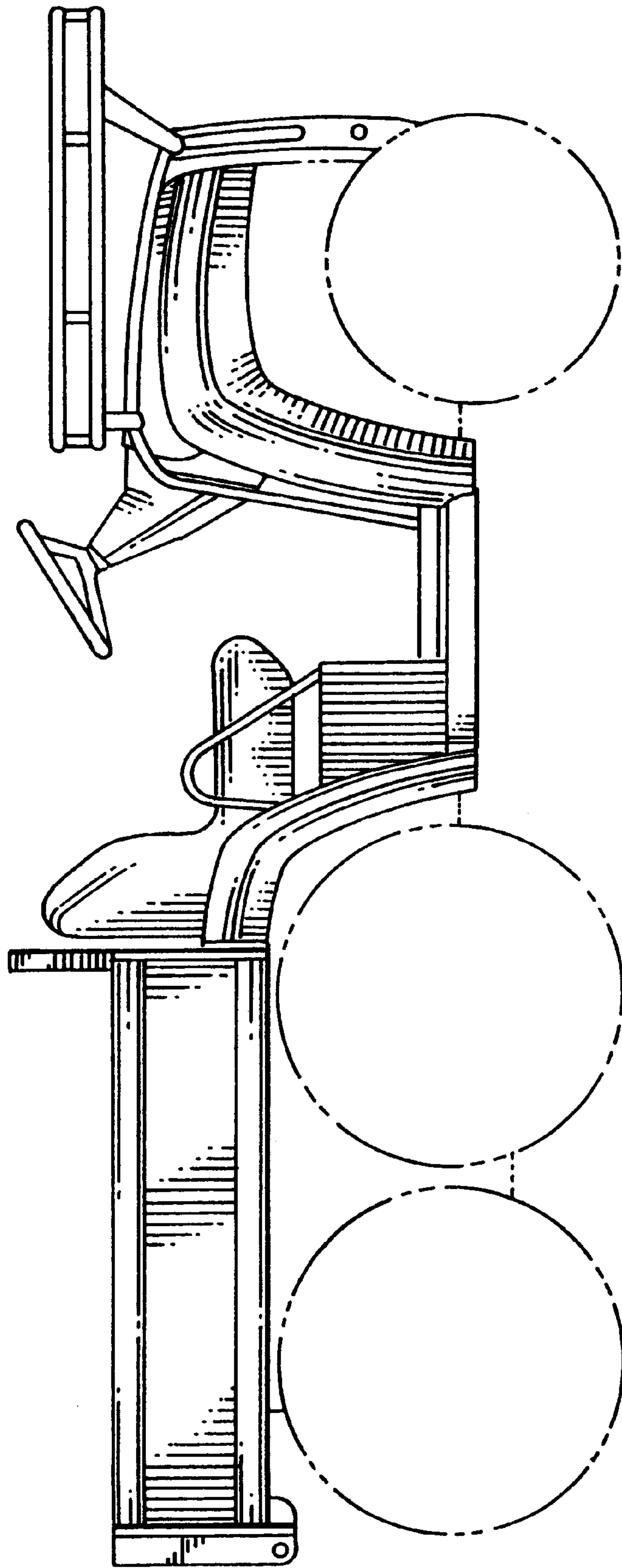

Fig. 4

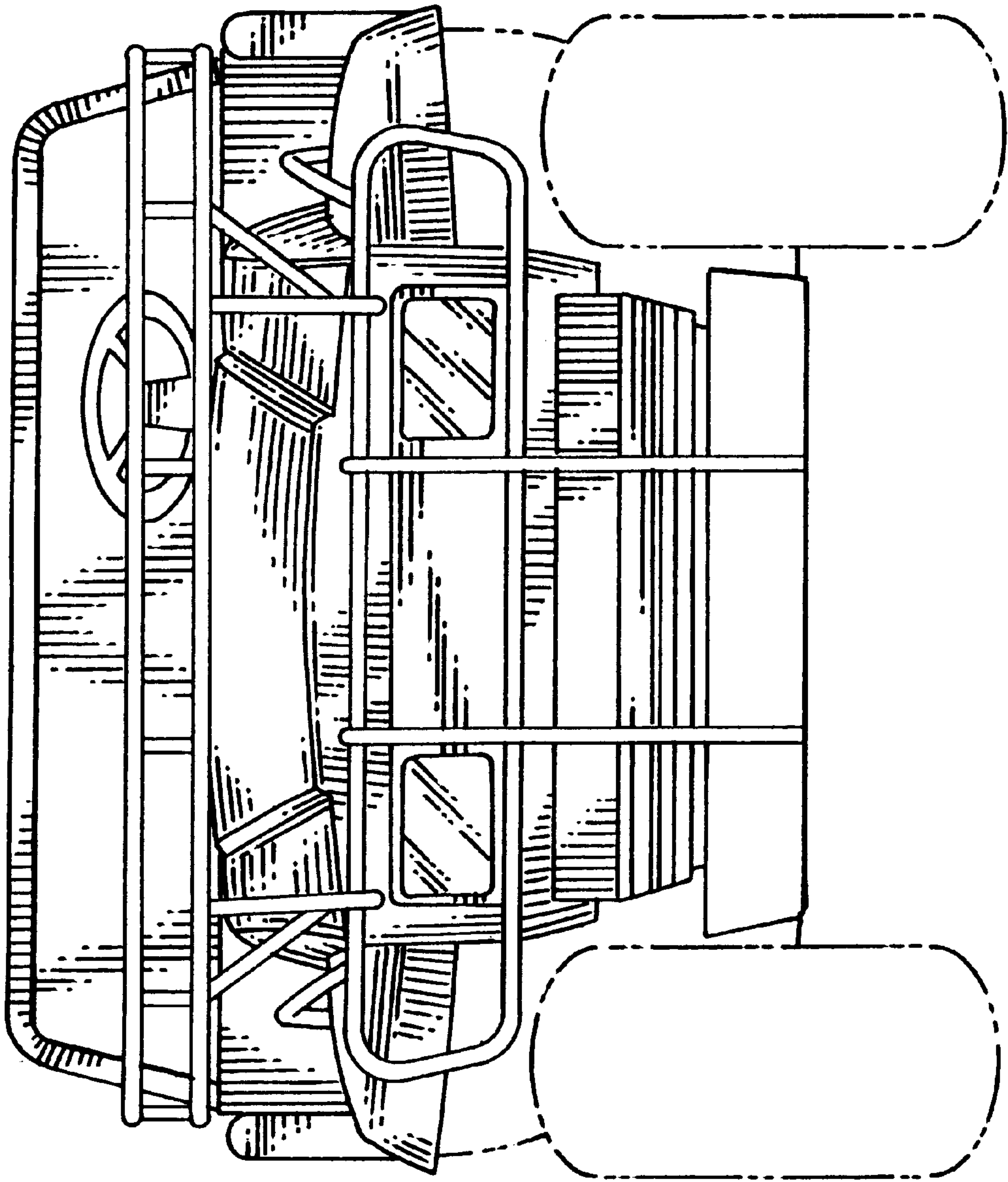

Fig. 5

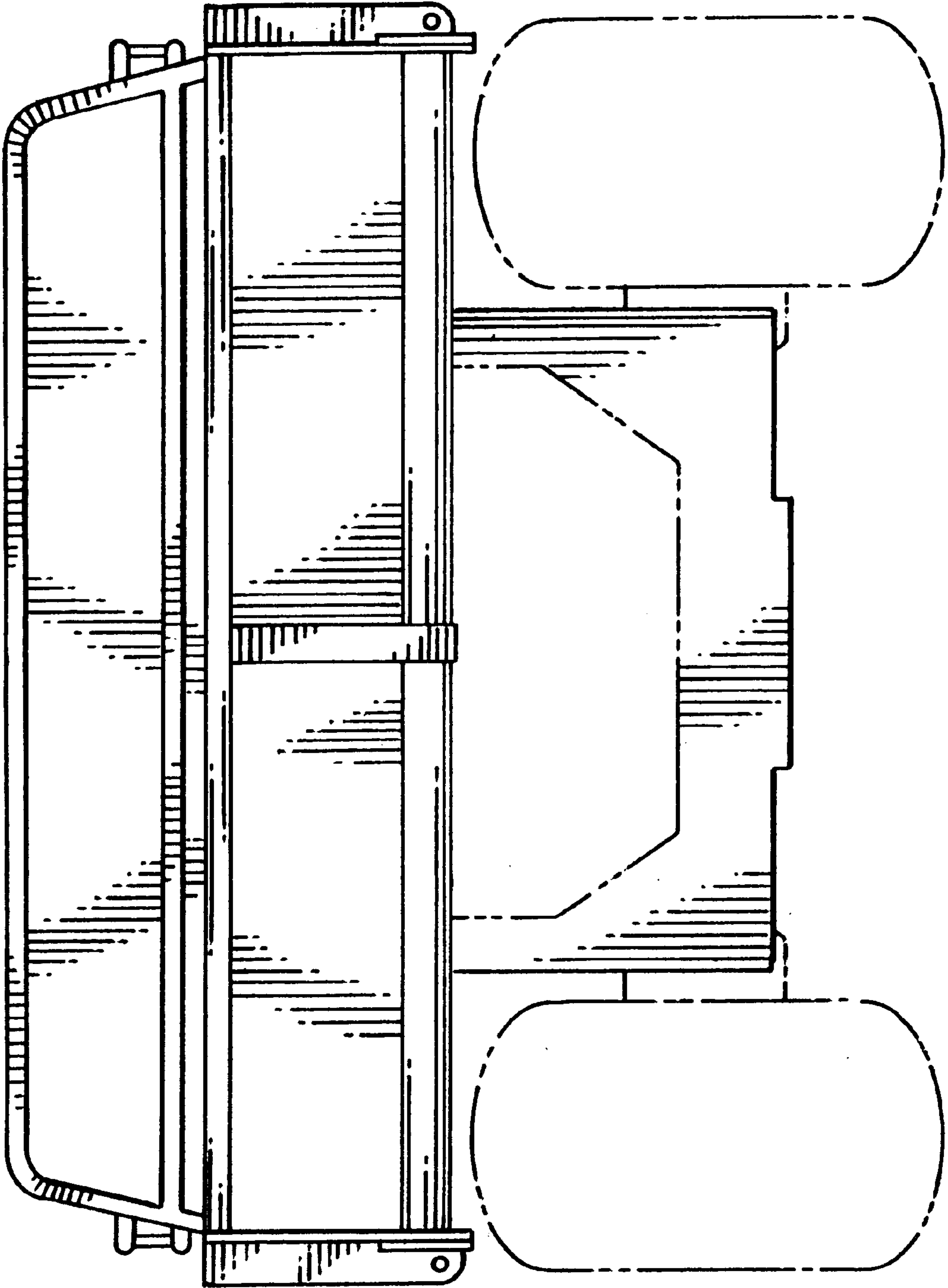

Fig. 6