



US00D439486S

(12) **United States Design Patent**
Izumisawa

(10) **Patent No.:** **US D439,486 S**

(45) **Date of Patent:** **** Mar. 27, 2001**

(54) **SQUARE DRIVE WRENCH HAVING ANGLED HEAD**

(75) Inventor: **Osamu Izumisawa**, Tokyo (JP)

(73) Assignee: **S.P. Air Kabusiki Kaisha**, Nagano (JP)

(**) Term: **14 Years**

(21) Appl. No.: **29/119,378**

(22) Filed: **Feb. 28, 2000**

(51) **LOC (7) Cl.** **08-05**

(52) **U.S. Cl.** **D8/70; D8/61**

(58) **Field of Search** **D8/61-70; 81/57.11, 81/57.13, 57.29, 54, 57.42, 57.39, 469; 173/170, 169, 48, 163, 217, 182; 451/358, 359; 310/50, 240; 433/82, 125**

(56) **References Cited**

U.S. PATENT DOCUMENTS

- D. 111,234 * 9/1938 Albertson D8/61
- D. 150,531 * 8/1948 Albertson D8/61

(List continued on next page.)

OTHER PUBLICATIONS

Vision Air Tool publication entitled, "Vision Air Tool VA-G120," published at least as early as Feb. 28, 2000 at <http://www.visionairtool.com/servlet/Cat_ShowDetails.class?105>.

Shinano Pneumatic Industries Inc. publication entitled, "SP Air," published at least as early as Feb. 28, 2000.

Ingersoll-Rand Co. publication entitled "Ingersoll-Rand Automotive Tools," published at least as early as Feb. 28, 2000, pp. 1-3, 16-17.

Ingersoll-Rand Co. publication entitled "Ingersoll-Rand Automotive Power Tools," published at least as early as Feb. 28, 2000, pp. 6-7, 26-27.

Shinano Pneumatic Industries Inc. publication entitled, "SP Air," published at least as early as Feb. 28, 2000, pp. 2-5, 16-19.

Primary Examiner—Jeffrey Asch

(74) *Attorney, Agent, or Firm*—Senniger, Powers, Leavitt & Roedel

(57) **CLAIM**

The ornamental design for a square drive wrench having angled head, as shown and described.

DESCRIPTION

FIG. 1 is a right side elevation of a square drive wrench having angled head of the present invention;

FIG. 2 is a left side elevation of the wrench;

FIG. 3 is a top plan of the wrench;

FIG. 4 is a bottom plan of the wrench;

FIG. 5 is a front elevation of the wrench; and,

FIG. 6 is a rear elevation of the wrench of the first embodiment.

The broken lines shown in the drawings indicate environmental structure and features which form no part of the claimed design.

1 Claim, 5 Drawing Sheets

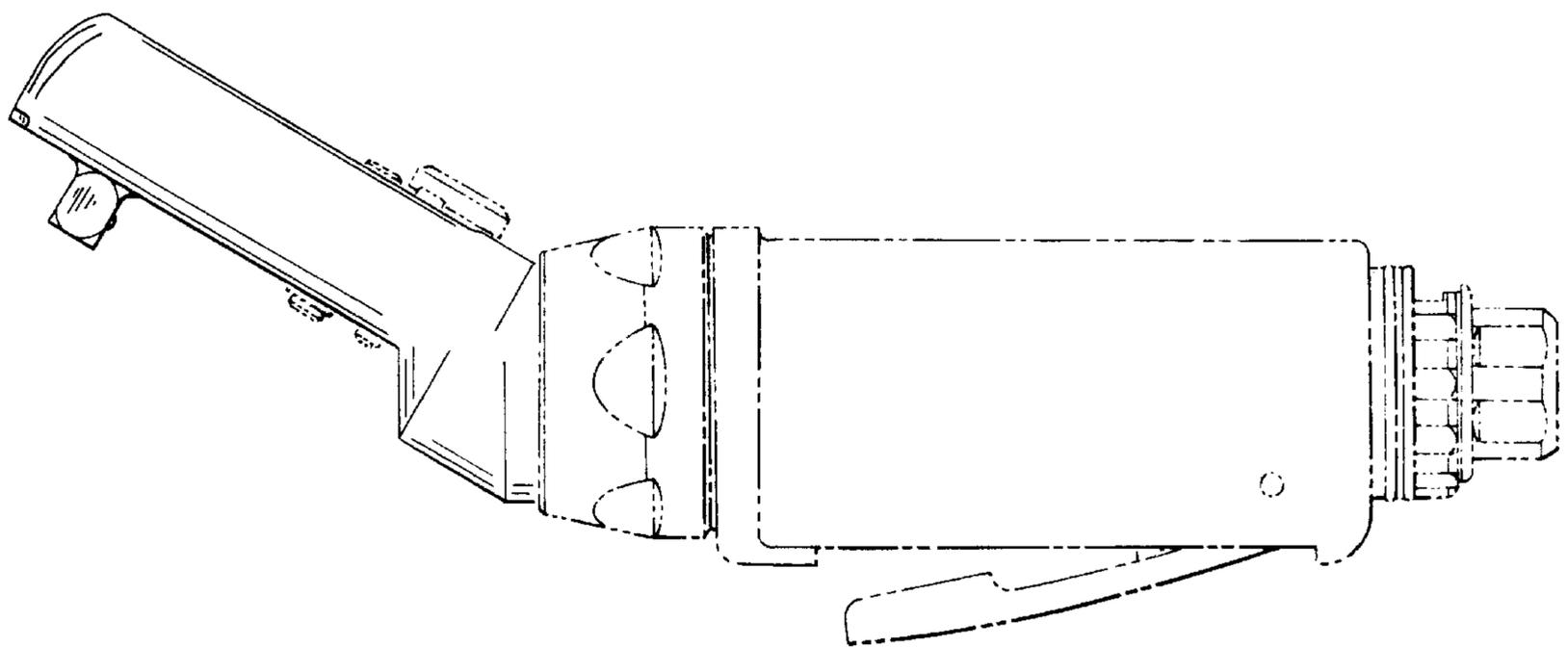

US D439,486 S

Page 2

U.S. PATENT DOCUMENTS

D. 162,877	*	4/1951	Price et al.	D8/70	D. 347,372	5/1994	Ghode et al. .		
D. 269,846	*	7/1983	Izumisawa	D8/62	D. 357,848	5/1995	Izumisawa .		
D. 269,938		8/1983	Izumisawa .		D. 361,028	8/1995	Izumisawa .		
D. 278,407		4/1985	Fleischer, Jr. .		D. 363,420	10/1995	Warner .		
D. 289,135		4/1987	Doman .		D. 372,850	*	8/1996	Dubuque et al. D8/61	
D. 298,908	*	12/1988	Clemens	D8/61	D. 376,083	12/1996	Verdura et al. .		
D. 302,378		7/1989	Nelson .		D. 380,658	7/1997	Bruno et al. .		
D. 316,216	*	4/1991	Gierke et al.	D8/61	D. 408,241	*	4/1999	Jansson	D8/61
D. 320,540		10/1991	Staubitz et al. .		D. 408,243	4/1999	Izumisawa .		
D. 320,541		10/1991	Staubitz et al. .		3,190,183	6/1965	Walker et al. .		
D. 323,275		1/1992	Sasaki et al. .		3,257,877	*	6/1966	Ulrich et al.	81/57.13
D. 323,603	*	2/1992	Fu	D8/61	4,006,784	*	2/1977	Dudek	173/182
D. 323,961	*	2/1992	Fushiya et al.	D8/61	4,184,257	*	1/1980	Leonard	433/82
D. 327,620		7/1992	Fisher .		4,185,386	*	1/1980	Nordin et al.	433/82
D. 330,151		10/1992	Fisher .		4,748,872	6/1988	Brown .		
D. 333,077		2/1993	Mikiya .		4,753,594	*	6/1988	Croll	433/125
D. 333,766		3/1993	Albert et al. .		4,821,611	4/1989	Izumisawa .		
D. 334,124		3/1993	Izumisawa .		5,383,771	1/1995	Ghode et al. .		
D. 334,125		3/1993	Izumisawa .		5,784,934	7/1998	Izumisawa .		
D. 335,808	*	5/1993	Bruno et al.	D8/61	6,009,776	*	1/2000	Warren	81/57.29
D. 336,228	*	6/1993	Anderson et al.	D8/61	6,087,754	*	7/2000	Berger	310/240

* cited by examiner

FIG. 1

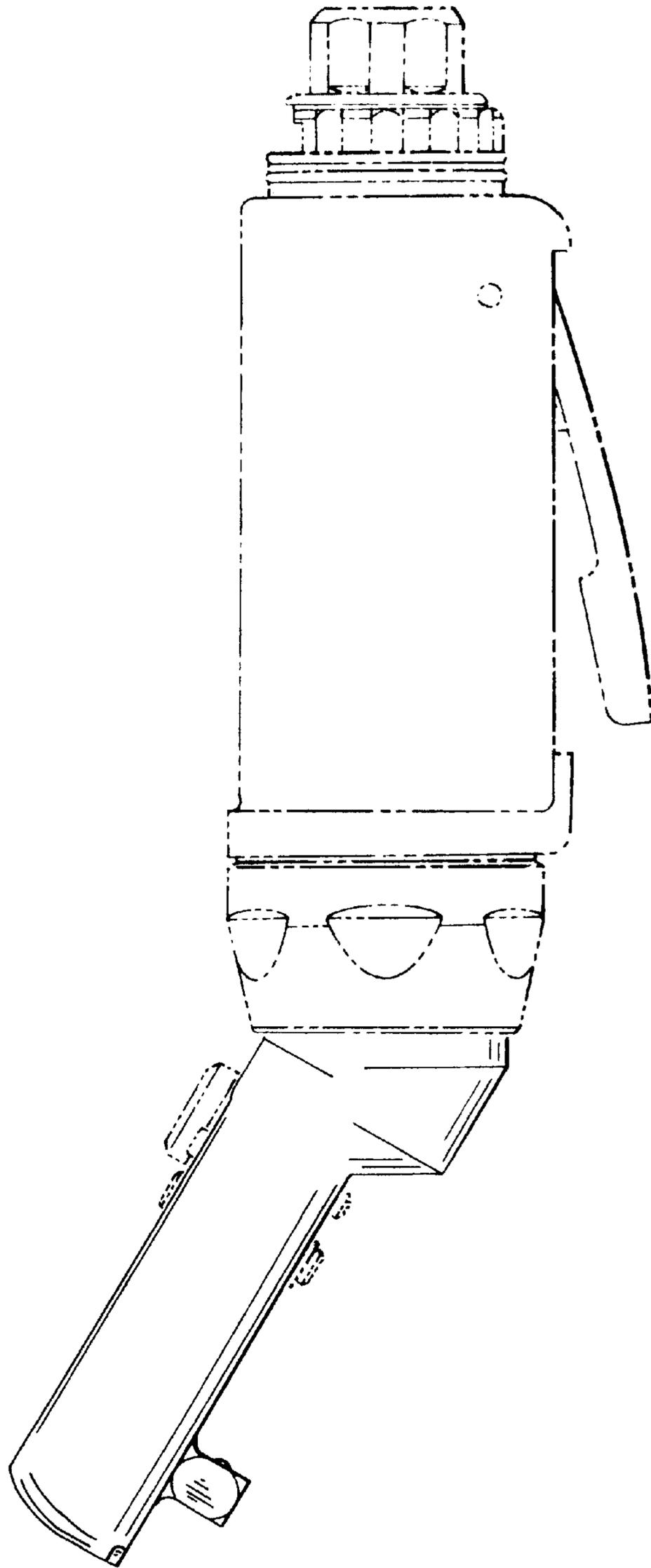

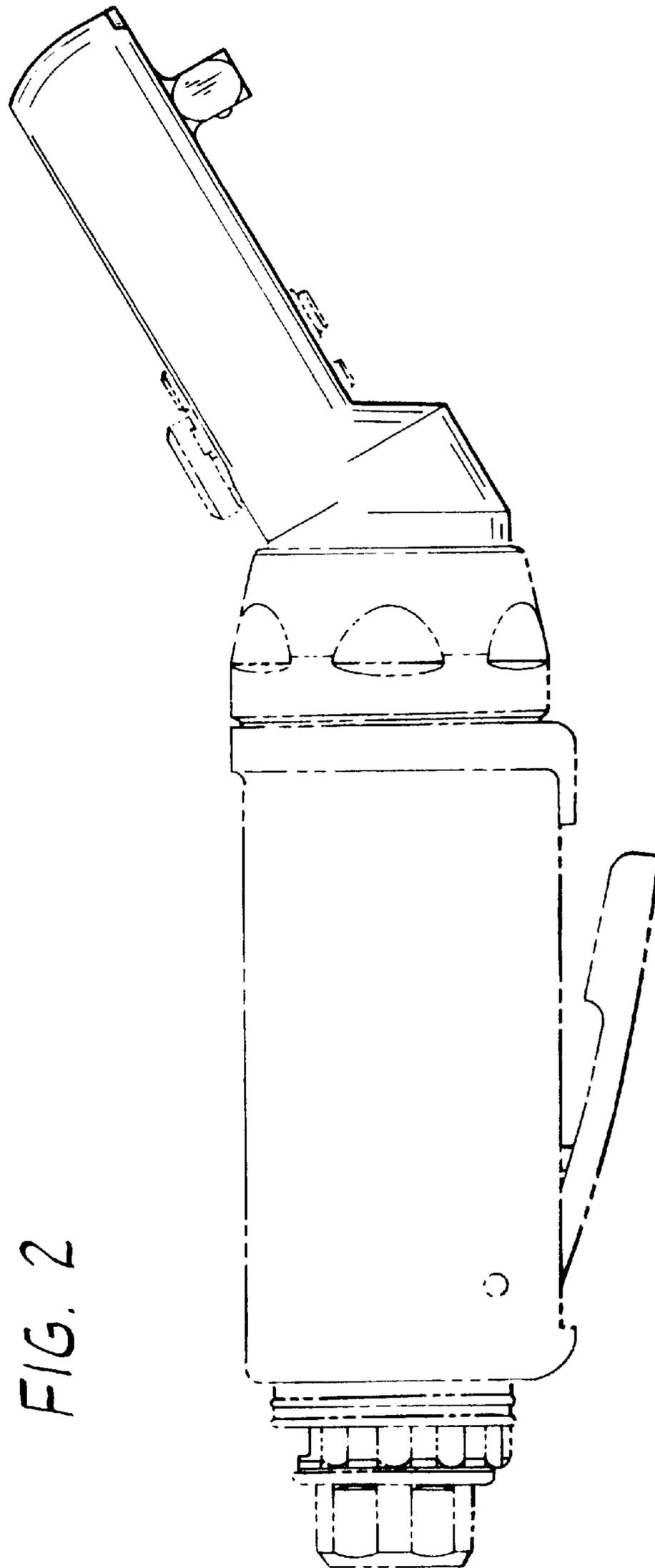

FIG. 2

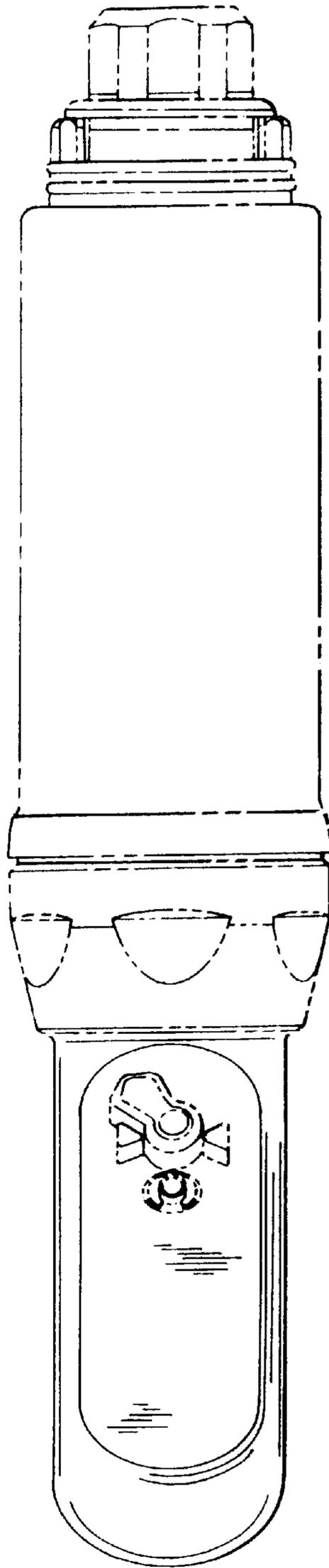

FIG. 3

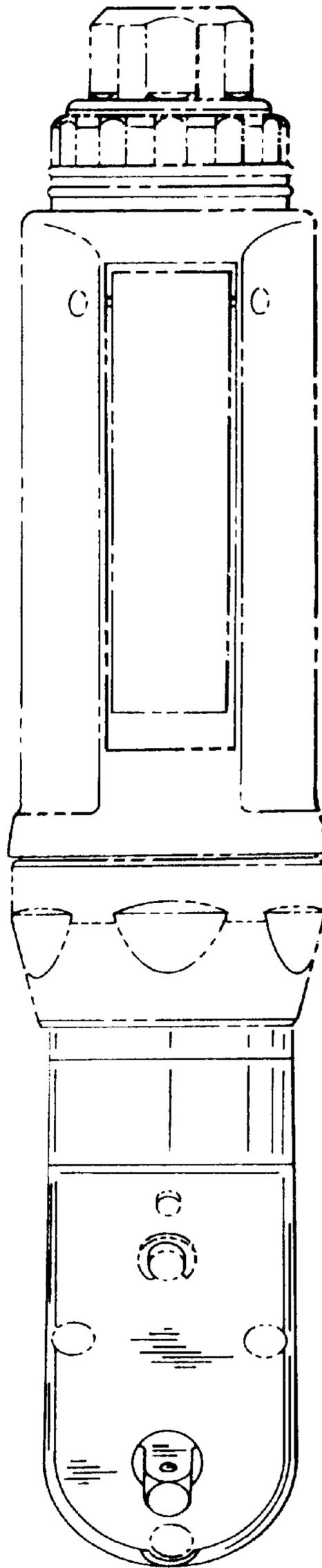

FIG. 4

