



US00D438841S

(12) **United States Design Patent**  
**Smith**

(10) **Patent No.:** **US D438,841 S**

(45) **Date of Patent:** **\*\* Mar. 13, 2001**

- (54) **CONSOLE FOR VAN VEHICLES**
- (75) Inventor: **Daniel G. Smith**, Grand Prairie, TX (US)
- (73) Assignee: **Texas Saddlebags Industries, Ltd.**, Arlington, TX (US)
- (\*\*) Term: **14 Years**
- (21) Appl. No.: **29/125,894**
- (22) Filed: **Jun. 30, 2000**
- (51) **LOC (7) Cl.** ..... **12-16**
- (52) **U.S. Cl.** ..... **D12/424**
- (58) **Field of Search** ..... D12/415, 419, D12/421, 423-426.1; 296/37.1-37.8, 37.12-37.16; 224/42.11, 539-543, 400, 926

- D. 397,083 \* 8/1998 Smith ..... D12/419
- D. 399,483 \* 10/1998 Paredes, Jr. .... D12/424
- D. 408,349 \* 4/1999 Smith ..... D12/424

\* cited by examiner

*Primary Examiner*—Stacia Cadmus  
(74) *Attorney, Agent, or Firm*—Daniel Rubin

(57) **CLAIM**

The ornamental design for a console for van vehicles, as shown and described.

**DESCRIPTION**

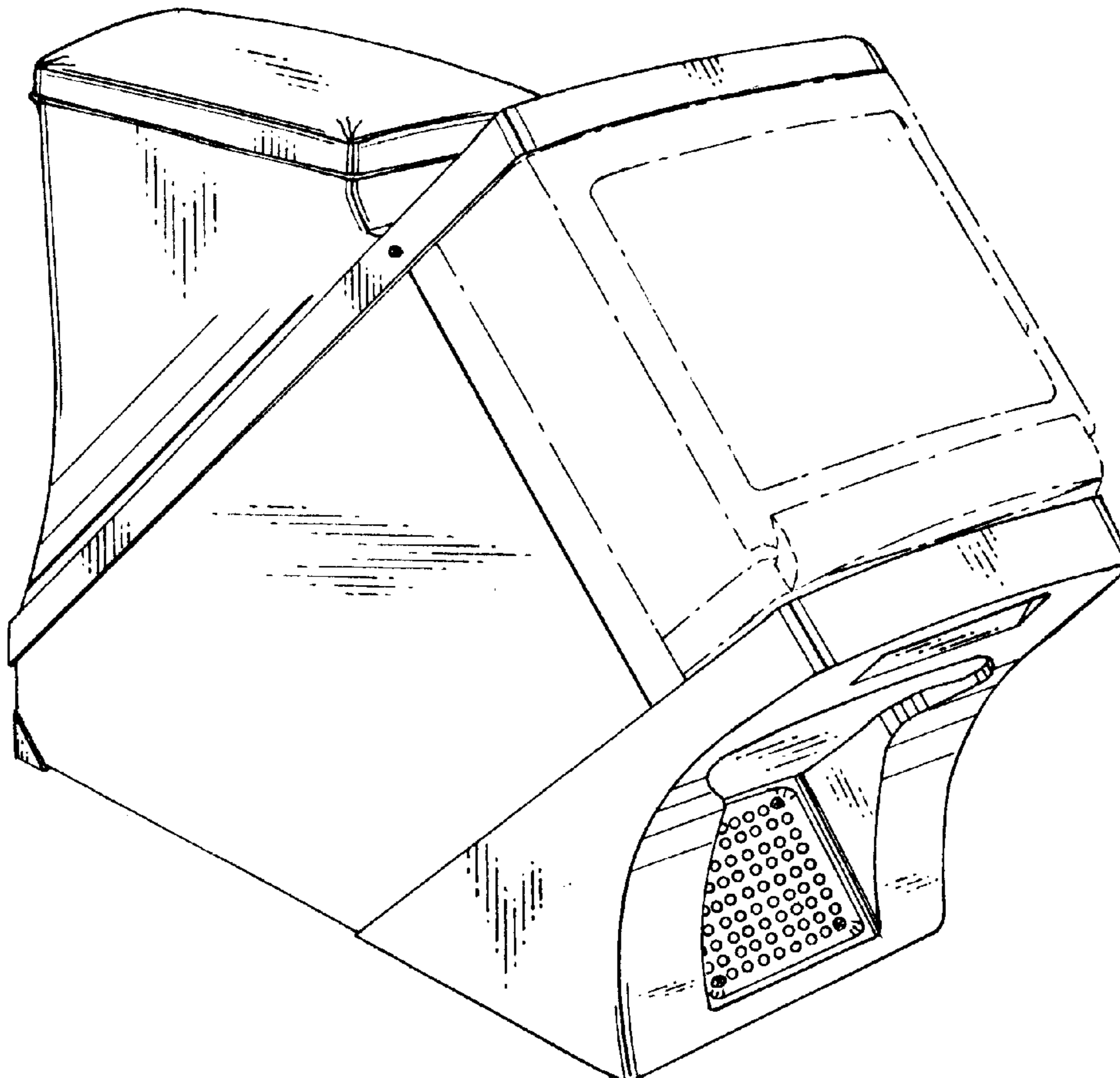
FIG. 1 is a left side perspective view of the console for van vehicles hereof showing my new design; FIG. 2 is a rear perspective elevational view thereof; FIG. 3 is a top plan view thereof with the rear closure door in a closed relation; FIG. 4 is left side elevation view thereof; FIG. 5 is a bottom plan view thereof; and, FIG. 6 is a top plan view thereof with the rear closure door in an open relation.

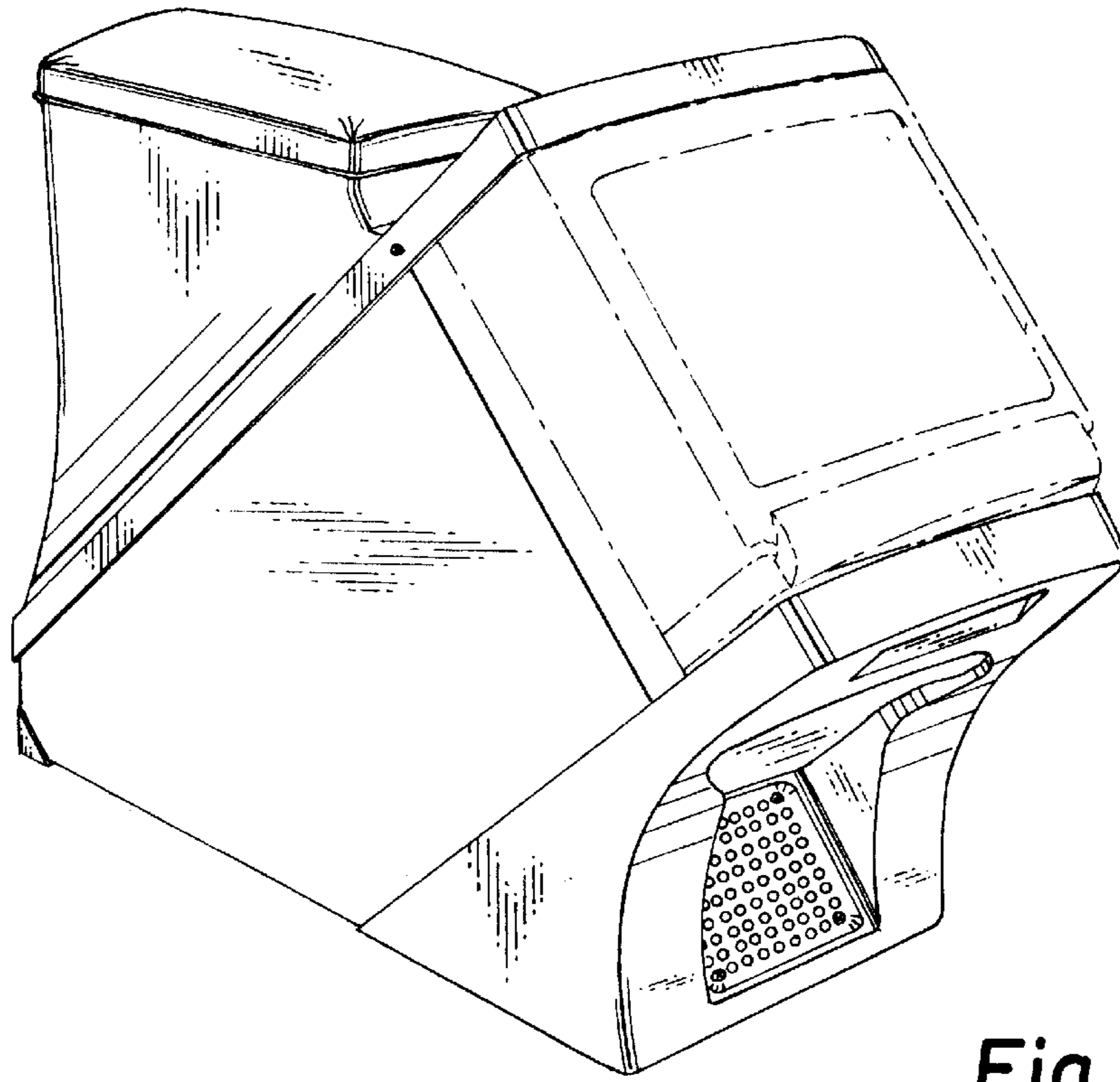
The broken line showing of environment is for illustrative purposes only and forms no part of the claimed design.

(56) **References Cited**  
**U.S. PATENT DOCUMENTS**

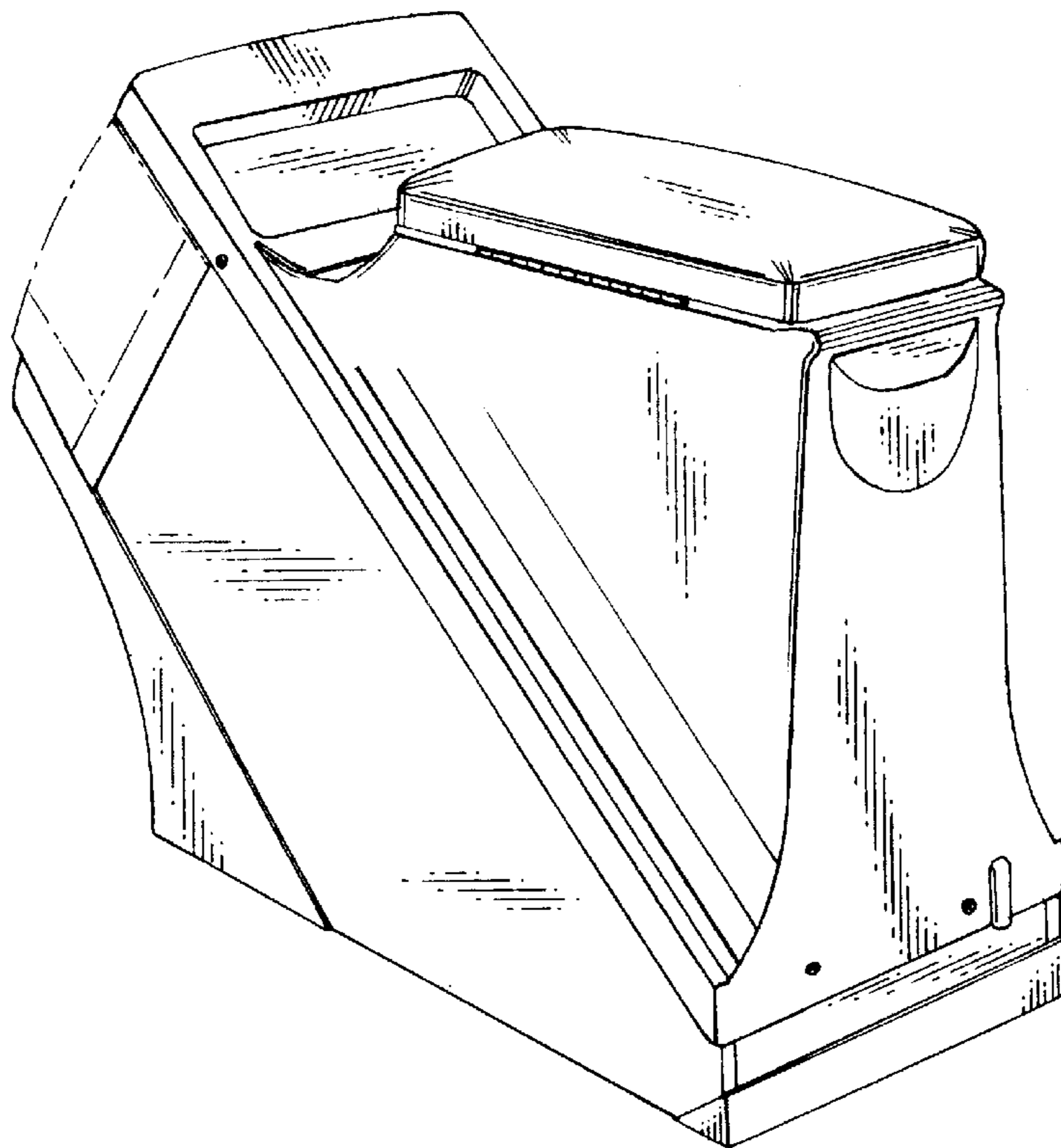
- D. 219,965 \* 2/1971 Boothe ..... D12/415
- D. 228,973 \* 10/1973 Waldsmith ..... D12/415
- D. 358,124 \* 5/1995 Landry ..... D12/423
- D. 375,480 \* 11/1996 Smith ..... D12/419
- D. 391,223 \* 2/1998 Lucas, Jr. .... D12/424

**1 Claim, 3 Drawing Sheets**

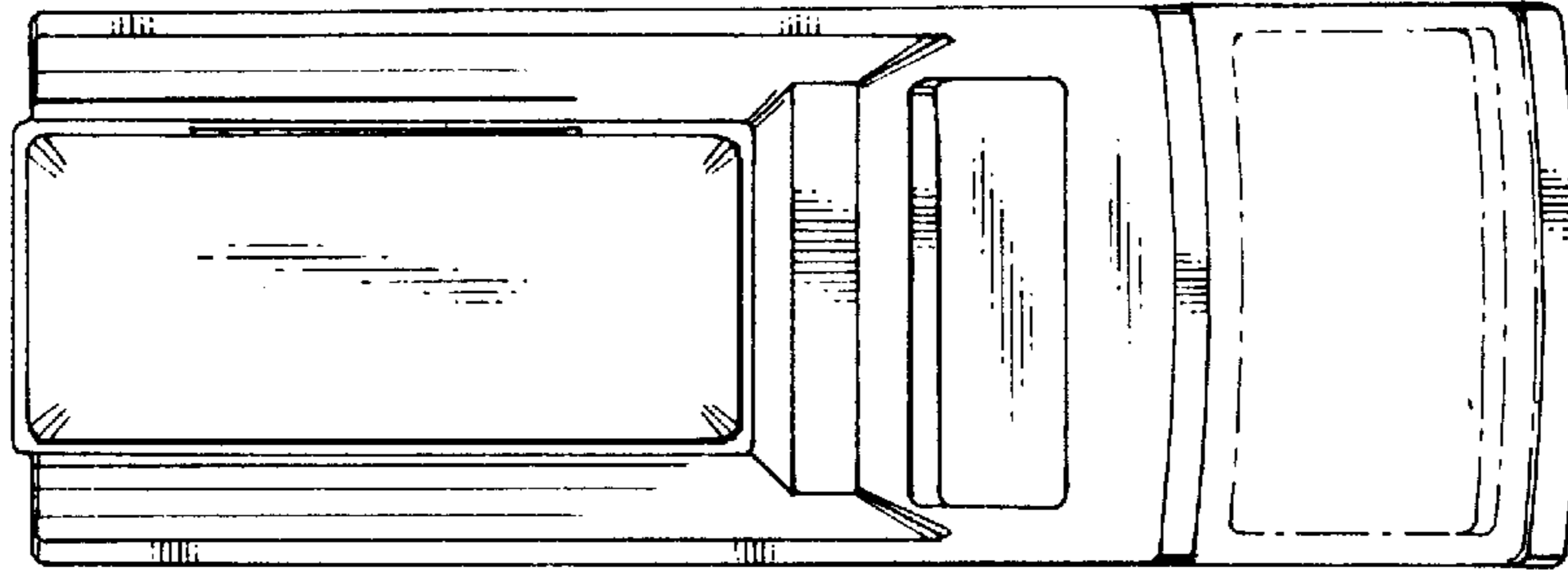




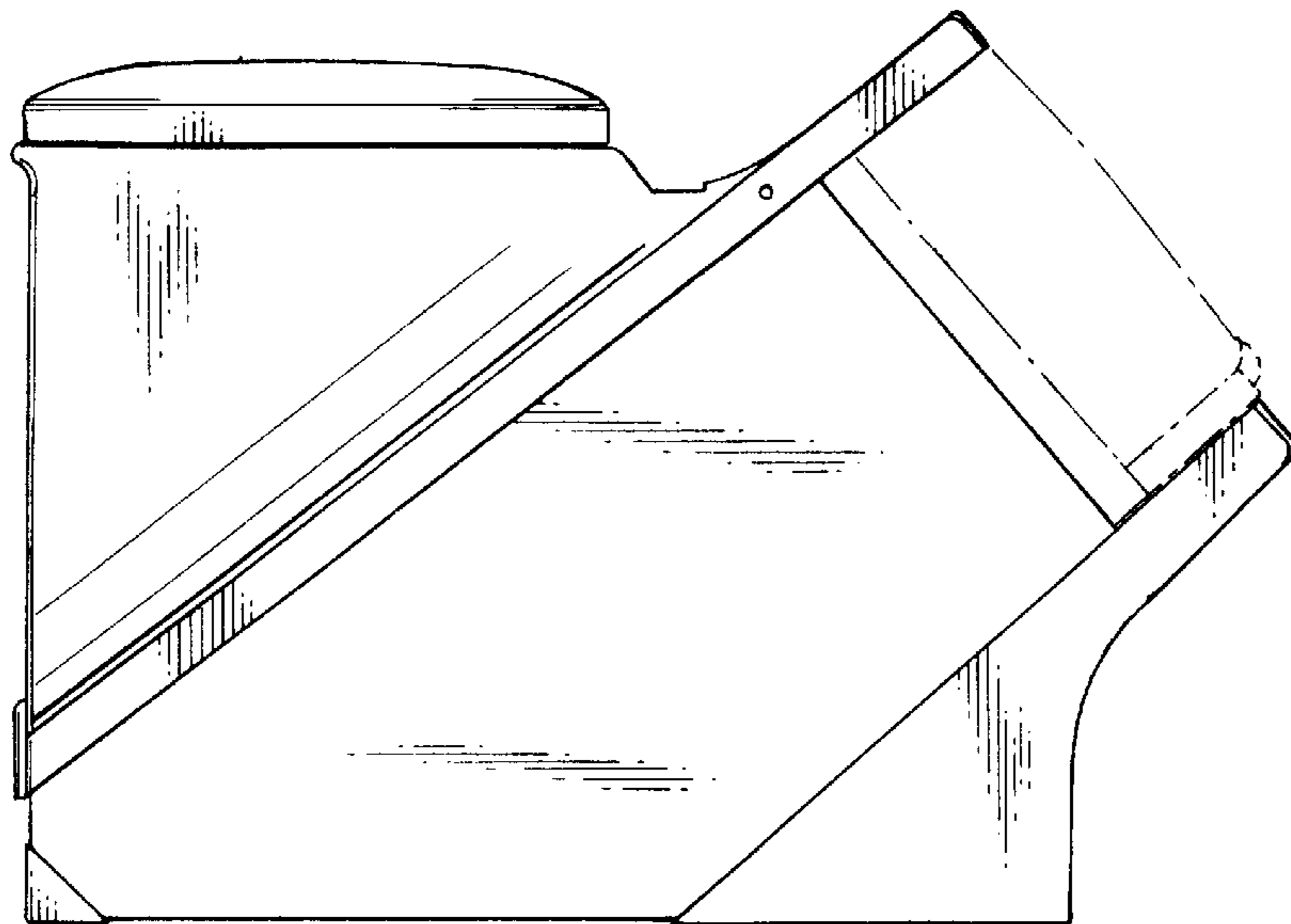
*Fig. 1*



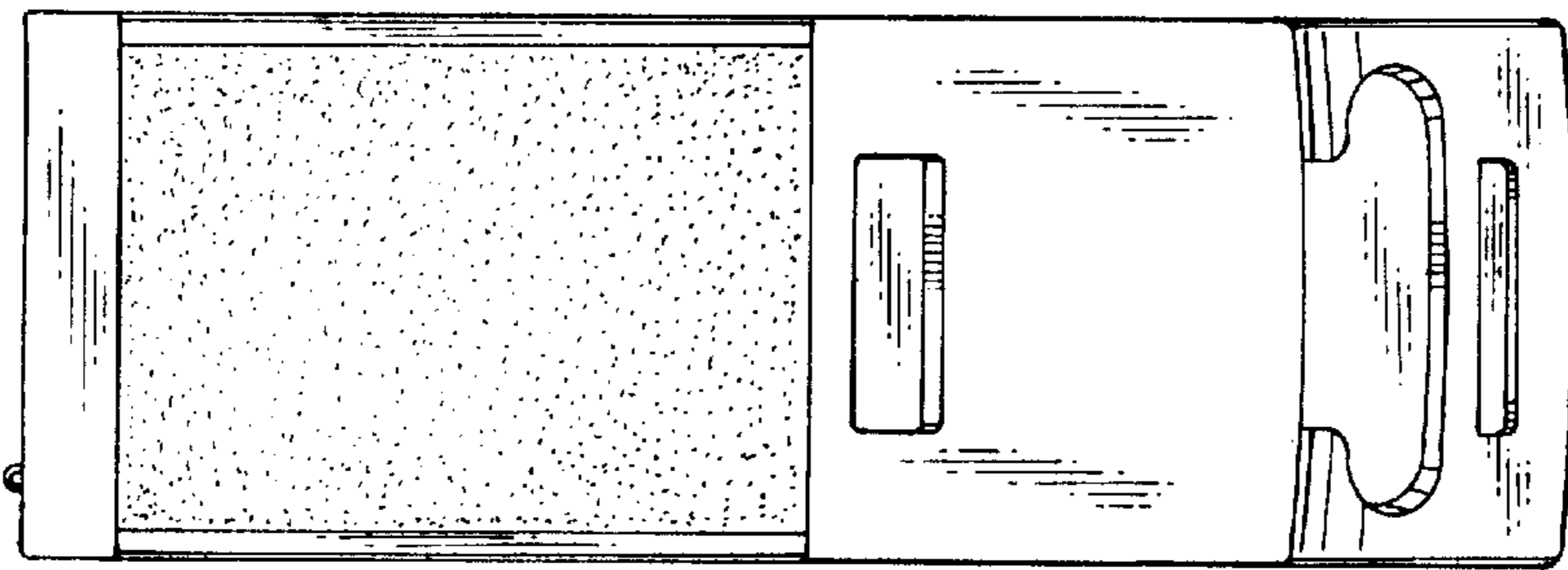
*Fig. 2*



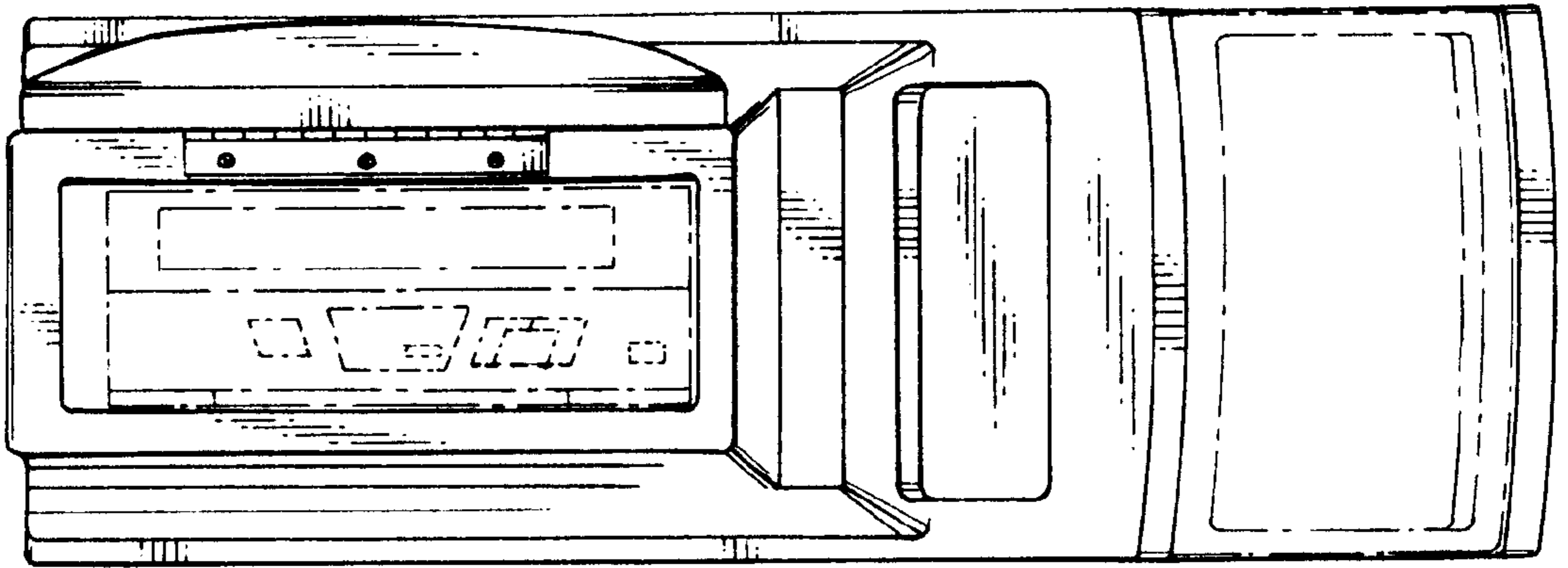
*Fig. 3*



*Fig. 4*



*Fig. 5*



*Fig. 6*