



US00D438806S

(12) **United States Design Patent**  
**Douglas et al.**

(10) **Patent No.:** **US D438,806 S**

(45) **Date of Patent:** **\*\* Mar. 13, 2001**

(54) **TAPE MEASURE HOUSING**

D. 419,081 \* 1/2000 Evans, Jr. et al. .... D10/72

(75) Inventors: **Patrick Douglas**, Minneapolis; **Tor Alden**, Minnetonka; **Charles Graves**, Woodbruy, all of MN (US)

\* cited by examiner

*Primary Examiner*—Antoine Duval Davis  
(74) *Attorney, Agent, or Firm*—Faegre & Benson LLP

(73) Assignee: **Target Brands, Inc.**, Minneapolis, MN (US)

(57) **CLAIM**

(\*\*) Term: **14 Years**

The ornamental design for a tape measure housing, as shown and described.

(21) Appl. No.: **29/120,434**

**DESCRIPTION**

(22) Filed: **Mar. 17, 2000**

FIG. 1 is a view in perspective of a tape measure housing. FIG. 2 is a front plan view of the tape measure housing of FIG. 1.

(51) **LOC (7) Cl.** ..... **10-04**

FIG. 3 is a top plan view of the tape measure housing of FIG. 1.

(52) **U.S. Cl.** ..... **D10/72**

FIG. 4 is a bottom view of the tape measure housing of FIG. 1.

(58) **Field of Search** ..... D10/72; 33/755-769; 242/252, 381.4, 381.5

FIG. 5 is an end view of the tape measure housing of FIG. 1; and,

(56) **References Cited**

FIG. 6 is an end plan views of the tape measure housing of FIG. 1.

**U.S. PATENT DOCUMENTS**

The broken line showing is for illustrative purposes only and forms no part of the claimed design.

- D. 350,703 \* 9/1994 Fifer ..... D10/72
- D. 415,047 \* 10/1999 Hsu ..... D10/72
- D. 418,435 \* 1/2000 Hsu ..... D10/72

**1 Claim, 2 Drawing Sheets**

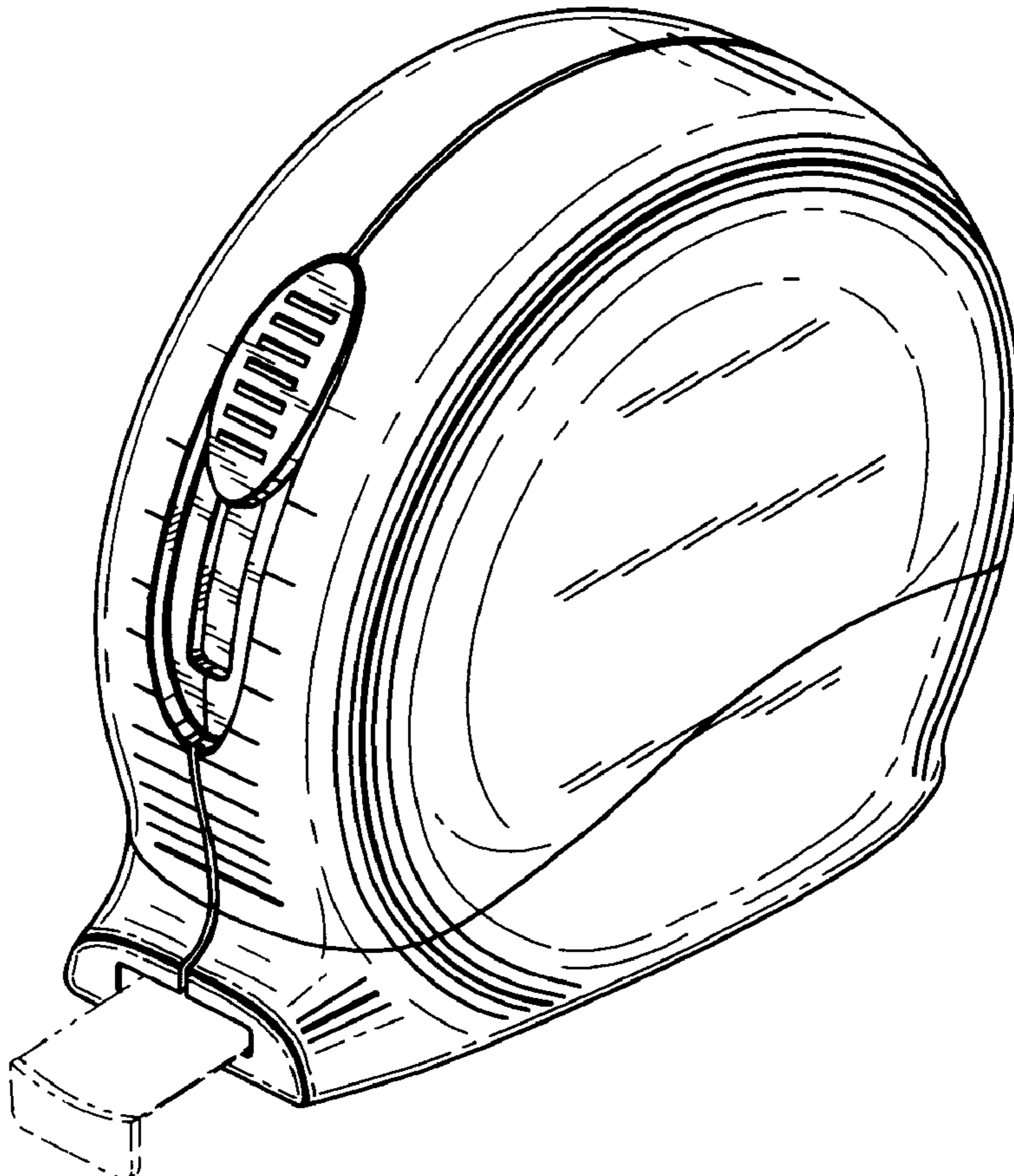

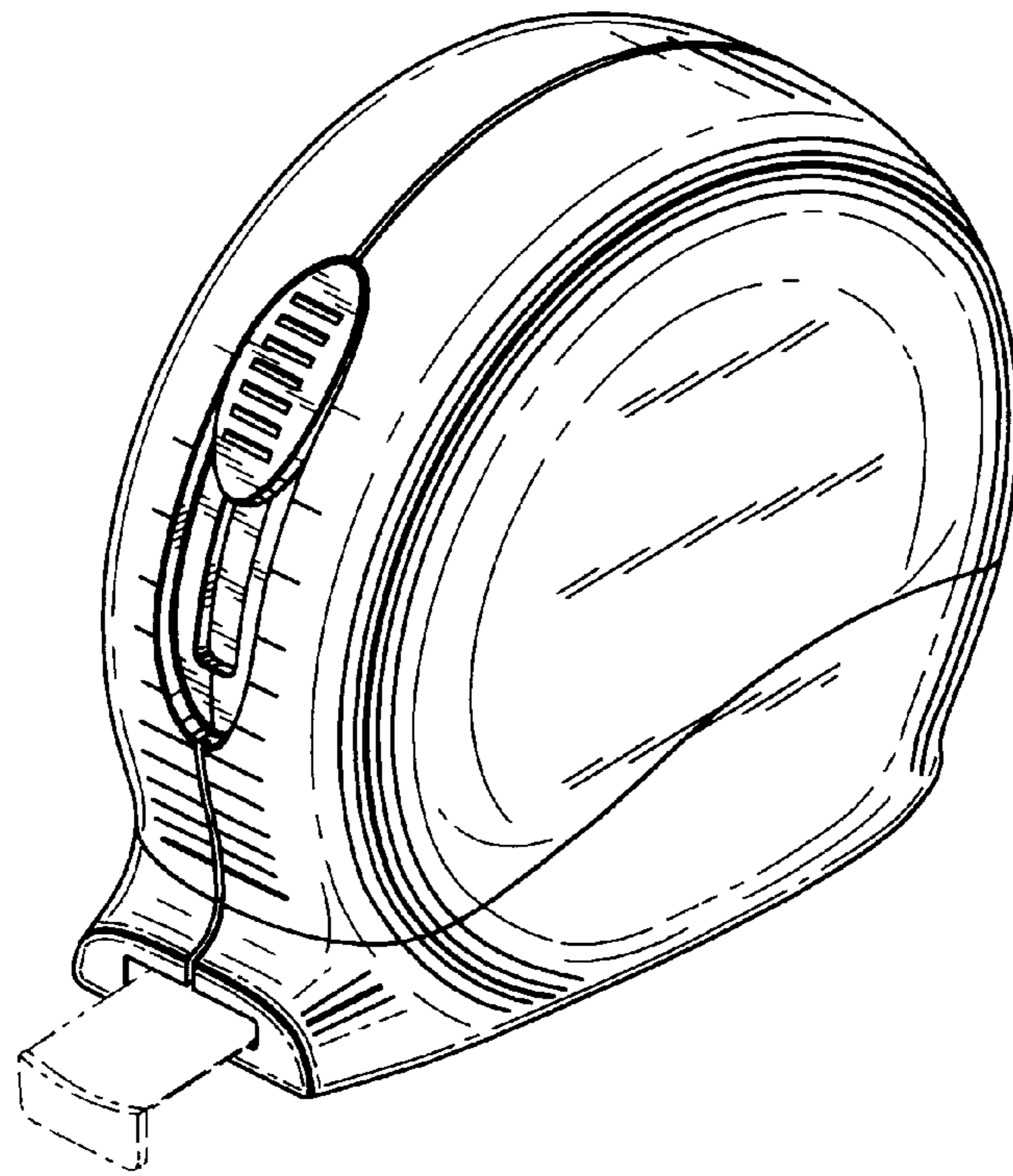

**Fig.1**

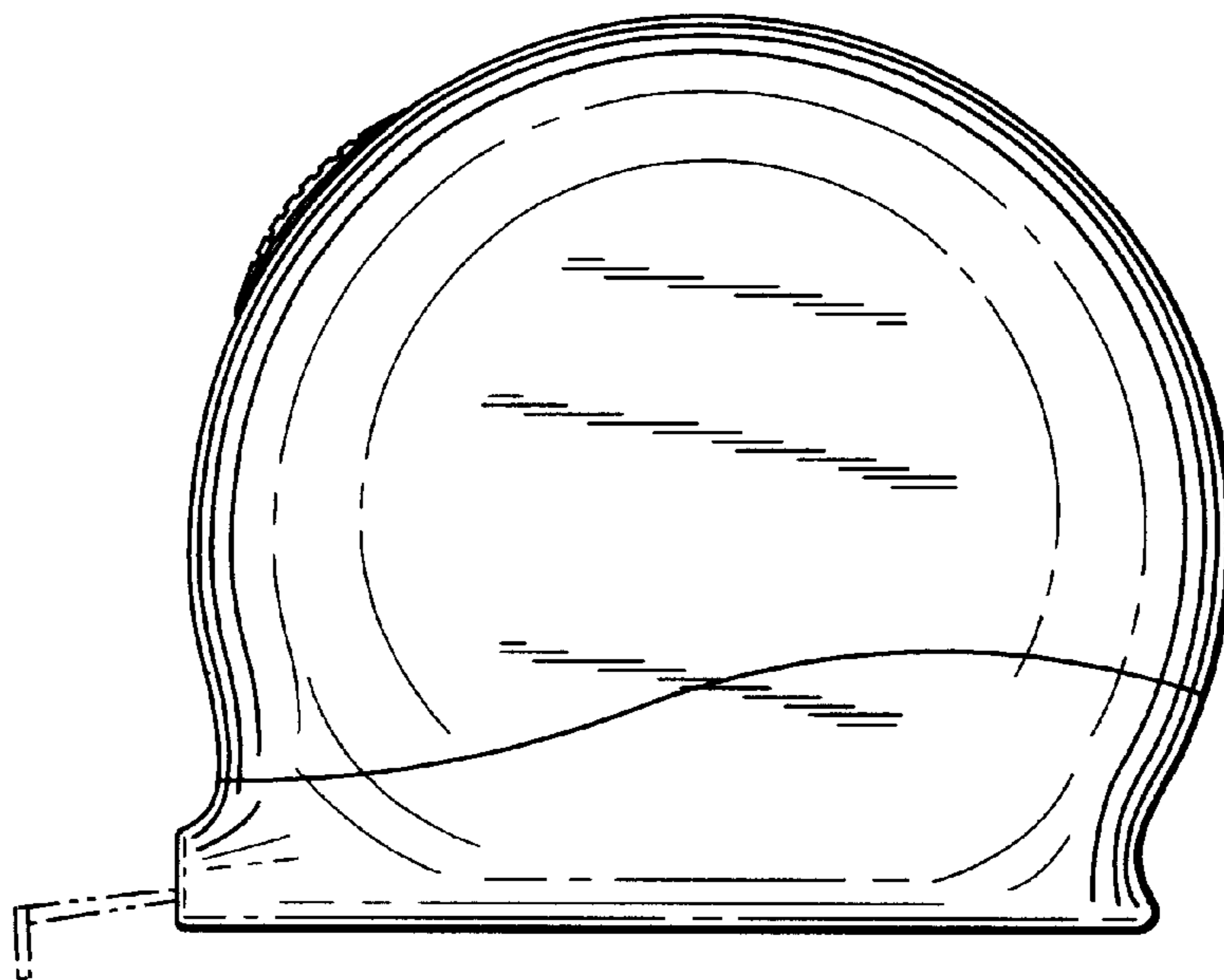

**Fig.2**

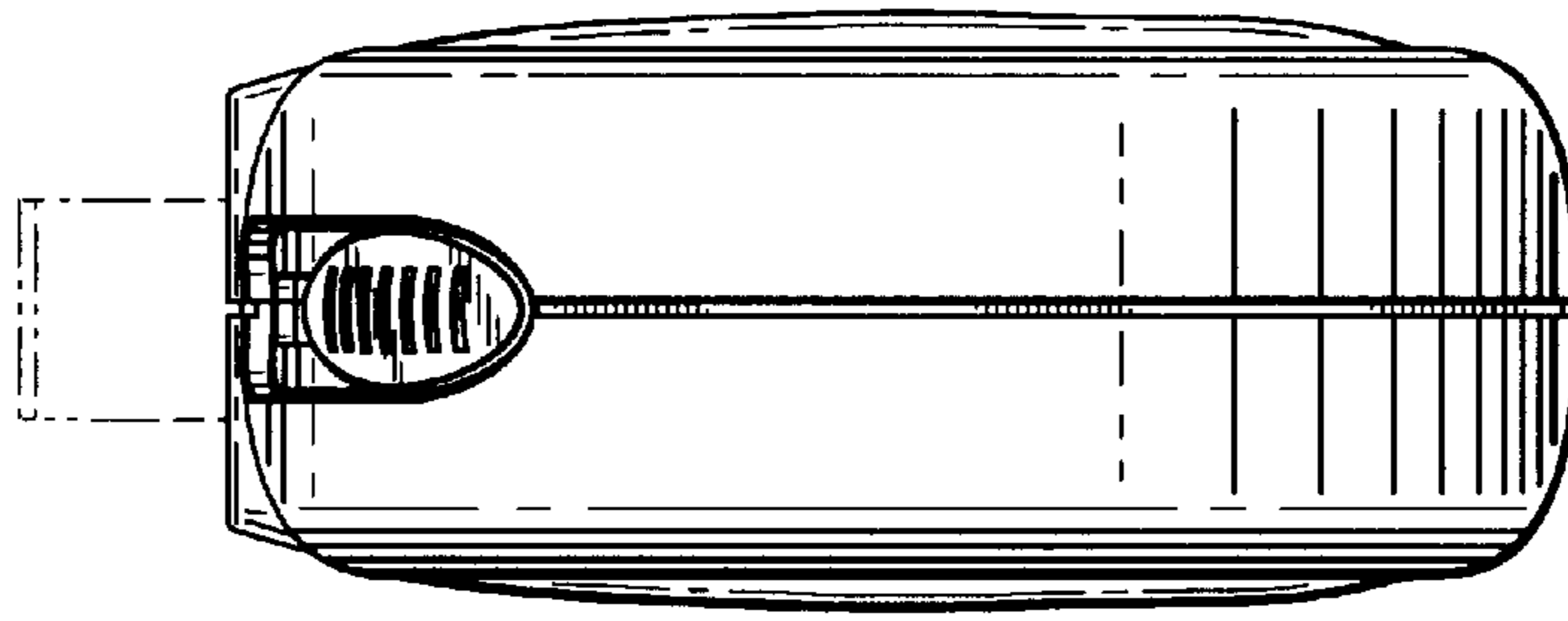

Fig.3

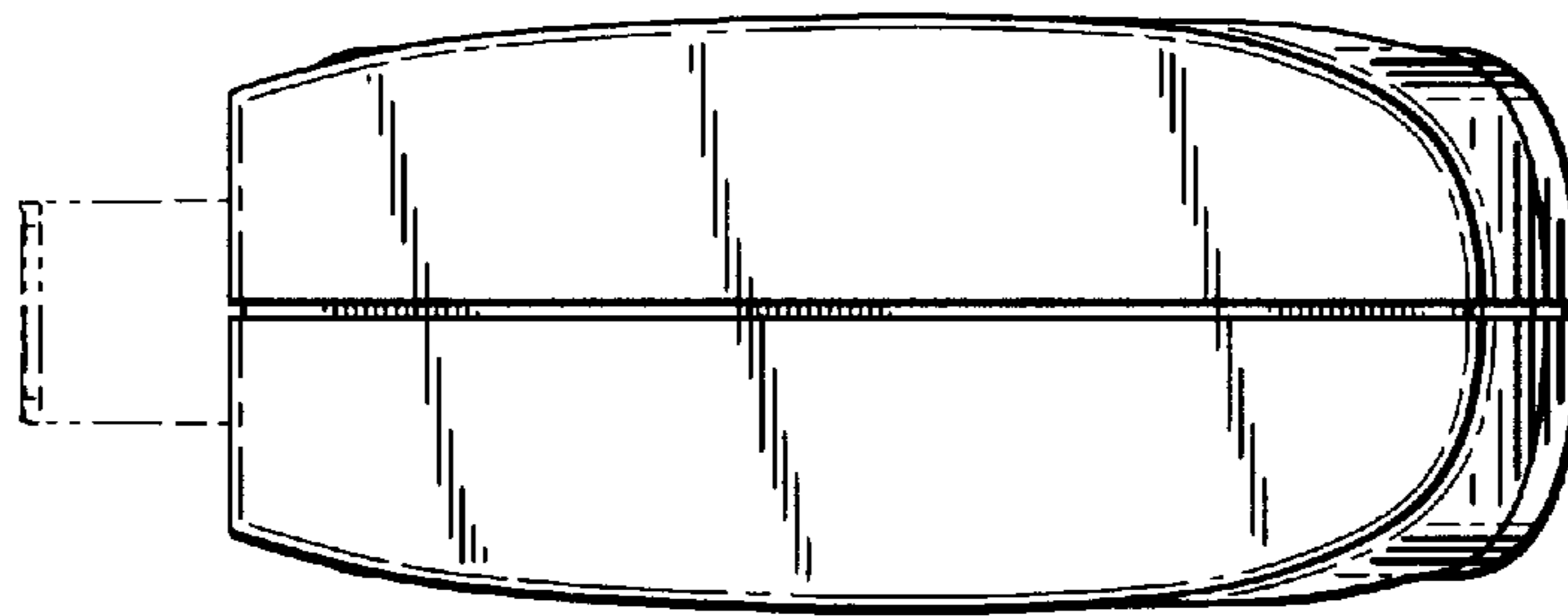

Fig.4

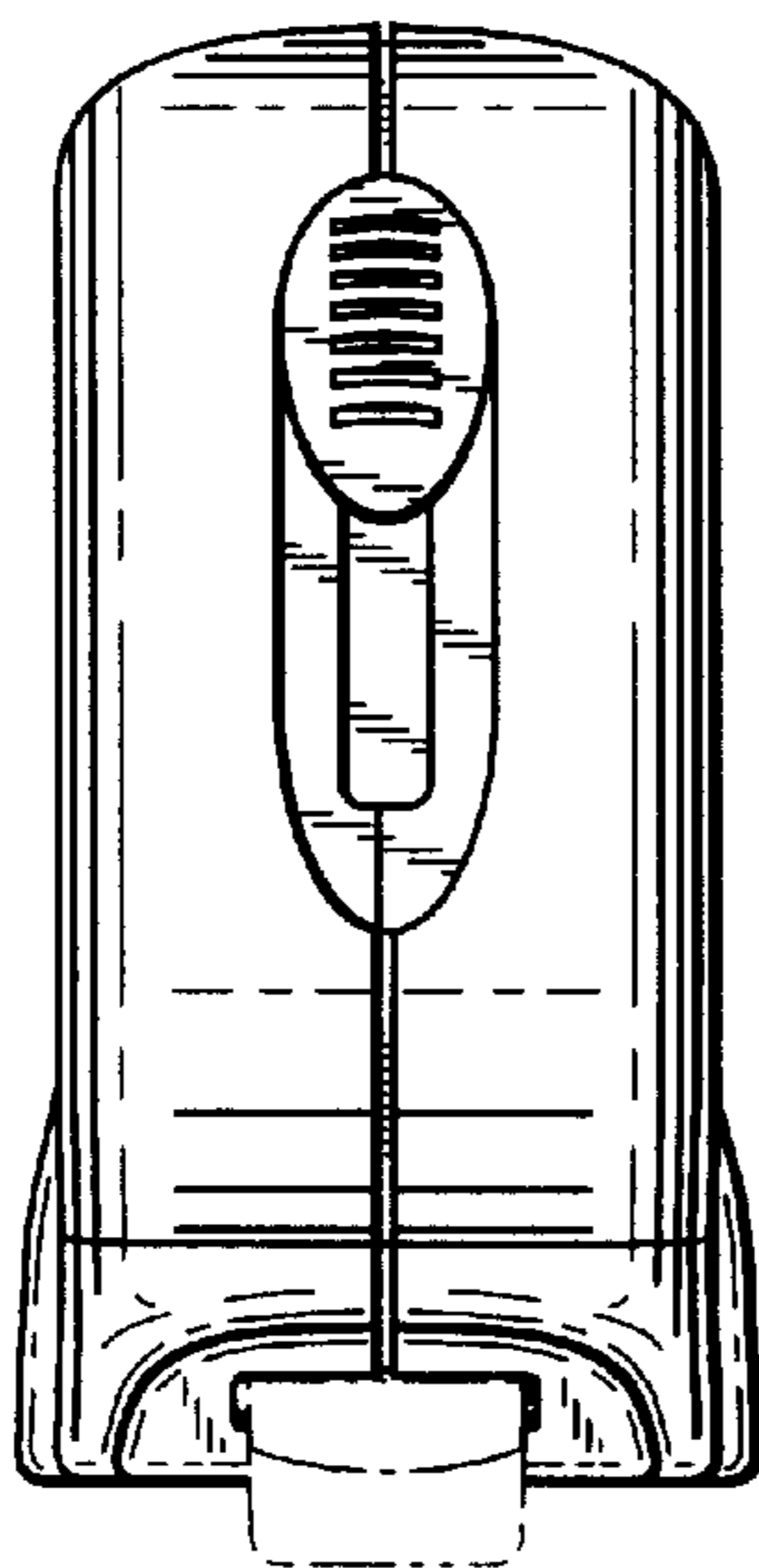

Fig.5

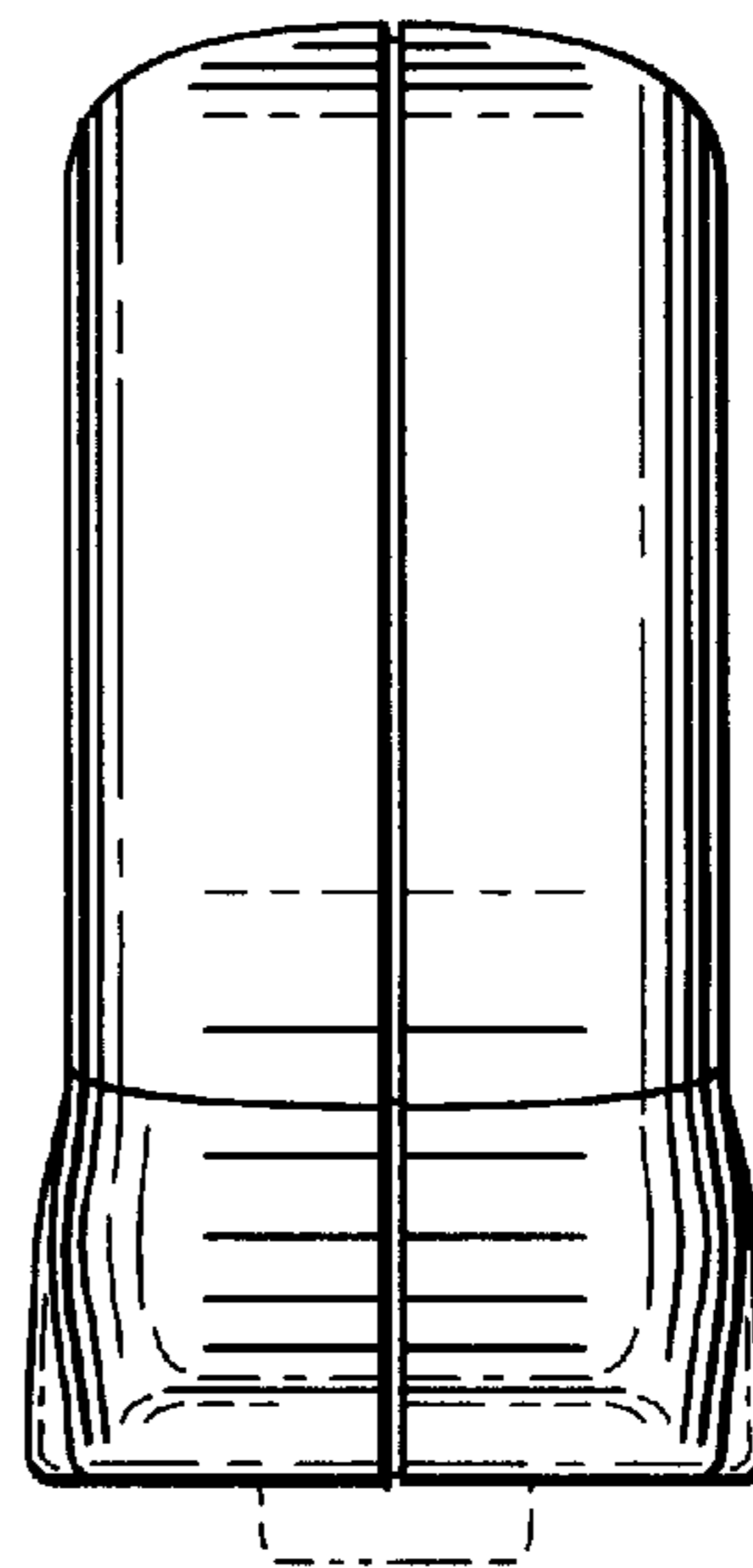

Fig.6