



US00D438507S

(12) **United States Design Patent**
Herndon

(10) **Patent No.:** **US D438,507 S**

(45) **Date of Patent:** **** Mar. 6, 2001**

(54) **TRUCK BED COVER**

(76) Inventor: **Brett S. Herndon**, 18521 Dallas La.,
Little Rock, AR (US) 72223

(**) Term: **14 Years**

(21) Appl. No.: **29/126,062**

(22) Filed: **Jul. 10, 2000**

(51) **LOC (7) Cl.** **12-16**

(52) **U.S. Cl.** **D12/401**

(58) **Field of Search** D12/401; 296/98-100;
160/26, 33, 133

(56) **References Cited**

U.S. PATENT DOCUMENTS

| | | | | | |
|------------|---|---------|------------|-------|---------|
| D. 190,418 | * | 5/1961 | Havens | | D12/401 |
| D. 213,361 | * | 2/1969 | Gardner | | D12/401 |
| D. 224,704 | * | 9/1972 | Hill | | D12/401 |
| D. 310,987 | * | 10/1990 | Law et al. | | D12/401 |
| D. 312,065 | * | 11/1990 | Karrer | | D12/401 |
| D. 327,668 | * | 7/1992 | Abele | | D12/401 |
| D. 335,850 | * | 5/1993 | Cyrson | | D12/401 |
| D. 343,602 | * | 1/1994 | Brown | | D12/401 |

| | | | | | |
|------------|---|---------|-----------|-------|---------|
| D. 350,108 | * | 8/1994 | Blanchard | | D12/401 |
| D. 403,292 | * | 12/1998 | Bogard | | D12/401 |
| D. 424,509 | * | 5/2000 | Meyers | | D12/401 |

* cited by examiner

Primary Examiner—Stacia Cadmus

(74) *Attorney, Agent, or Firm*—Dennis B. Haase

(57) **CLAIM**

The ornamental design for a truck bed cover, as shown and described.

DESCRIPTION

FIG. 1 is a perspective view of a truck bed cover, showing my new design, shown in its position of use;
 FIG. 2 is a top plan view thereof;
 FIG. 3 is a rear plan view thereof;
 FIG. 4 is a front plan view thereof;
 FIG. 5 is a side elevation view thereof, it being understood that the opposite side is a mirror image thereof; and,
 FIG. 6 is a bottom plan view thereof.
 The broken line showing of environment is for illustrative purposes only and forms no part of the claimed design.

1 Claim, 2 Drawing Sheets

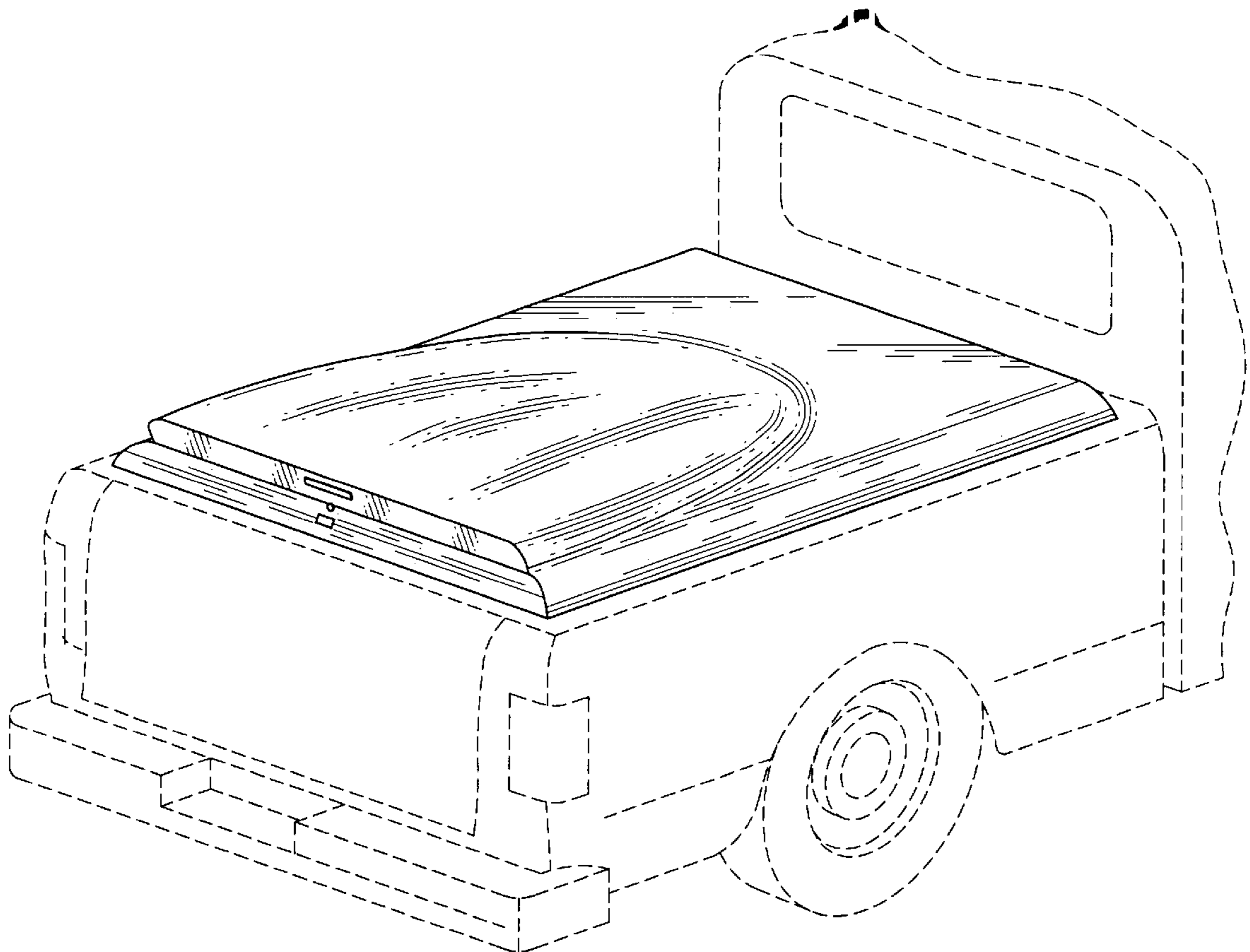

Fig. 1

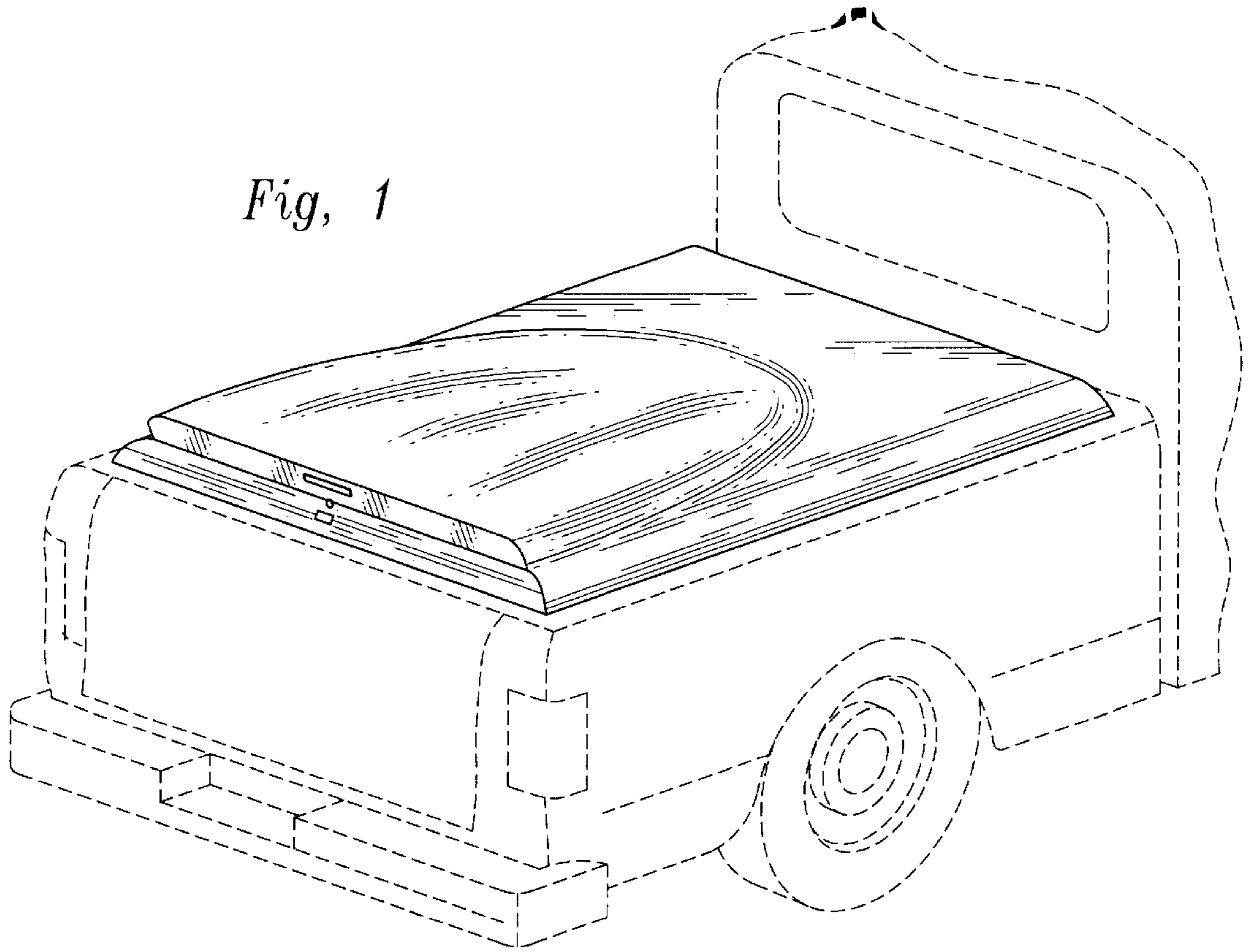

Fig. 2

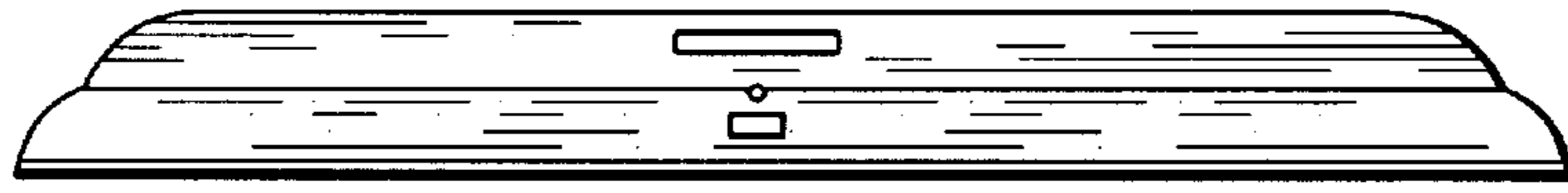

Fig. 3

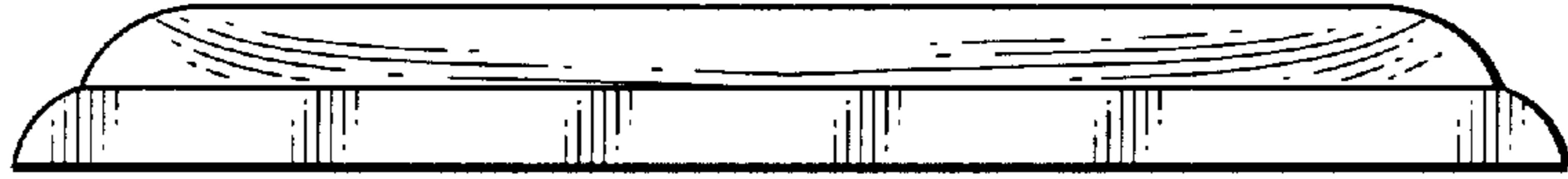

Fig. 4



Fig. 5

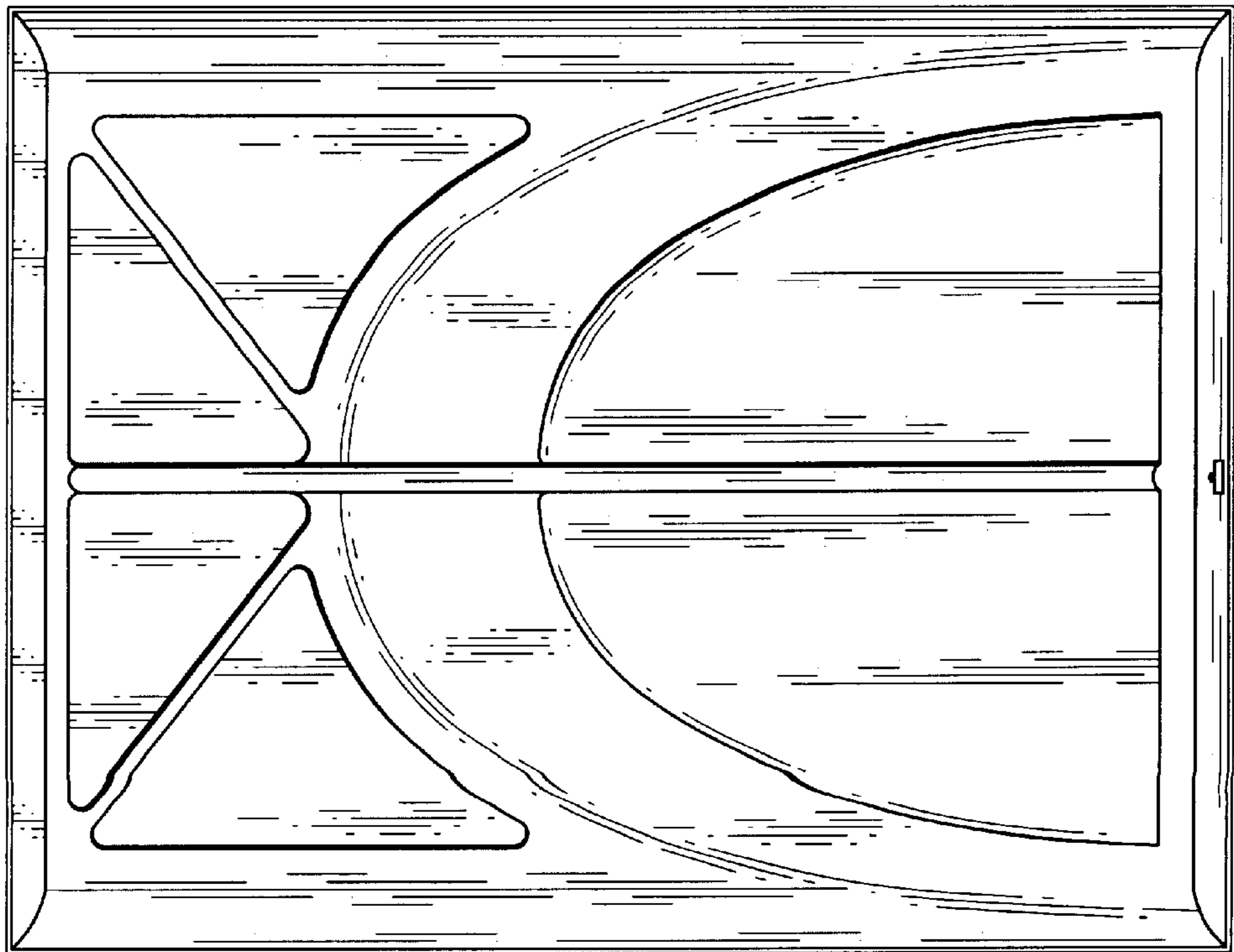

Fig. 6