



US00D438359S

(12) **United States Design Patent**  
**Braud**

(10) **Patent No.:** **US D438,359 S**

(45) **Date of Patent:** **\*\* Feb. 27, 2001**

(54) **FORKLIFT VEHICLE**

4,674,944 \* 6/1987 Addleman ..... 414/708  
4,986,721 \* 1/1991 Lowder et al. .... 414/722

(75) Inventor: **Marcel-Claude Braud**, Champtoceaux (FR)

\* cited by examiner

(73) Assignee: **Manitou BF**, Ancenis (FR)

*Primary Examiner*—Sandra L. Morris

(74) *Attorney, Agent, or Firm*—Baker Botts L.L.P.

(\*\*) Term: **14 Years**

(57) **CLAIM**

(21) Appl. No.: **29/105,085**

The ornamental design for a forklift vehicle, as shown and described.

(22) Filed: **May 17, 1999**

(30) **Foreign Application Priority Data**

Nov. 18, 1998 (FR) ..... 98 6677

(51) **LOC (7) Cl.** ..... **12-05**

(52) **U.S. Cl.** ..... **D34/34; D15/23**

(58) **Field of Search** ..... D12/87, 88; D15/10,  
D15/22-26; D34/34, 28; 180/89.1, 89.12,  
89.13; 296/190.1, 190.8, 202; 414/680,  
685, 722, 724, 743

**DESCRIPTION**

FIG. 1 is pictorial view of the right side of a forklift vehicle according to my new design;

FIG. 2 is a pictorial view of the left side of the forklift vehicle shown in FIG. 1;

FIG. 3 is a pictorial view of the front of the forklift vehicle shown in FIGS. 1 and 2;

FIG. 4 is a pictorial view of the back of the forklift vehicle shown in FIGS. 1 to 3;

FIG. 5 is a three-quarter pictorial view of the right side of the forklift vehicle shown in FIGS. 1 to 4, the view being taken from a vantage point to the rear;

FIG. 6 is a three-quarter pictorial view of the left side of the forklift vehicle shown in FIGS. 1 to 5, the view being taken from a vantage point to the front; and,

FIG. 7 is a three-quarter front pictorial view of the forklift vehicle shown in FIGS. 1 to 6, the view being taken from a vantage point to the right.

(56) **References Cited**

**U.S. PATENT DOCUMENTS**

- D. 295,523 \* 5/1988 Gano ..... D15/25
- D. 332,856 \* 1/1993 Krayem ..... D34/28
- D. 355,292 \* 2/1995 Soederberg ..... D34/28
- D. 366,489 \* 1/1996 Brown ..... D15/22
- D. 405,807 \* 2/1999 Amy et al. .... D15/25
- D. 412,506 \* 8/1999 Boyer et al. .... D15/25
- D. 416,266 \* 11/1999 Del Torchio ..... D15/25
- 3,924,524 \* 12/1975 Whisler ..... 454/161

**1 Claim, 7 Drawing Sheets**

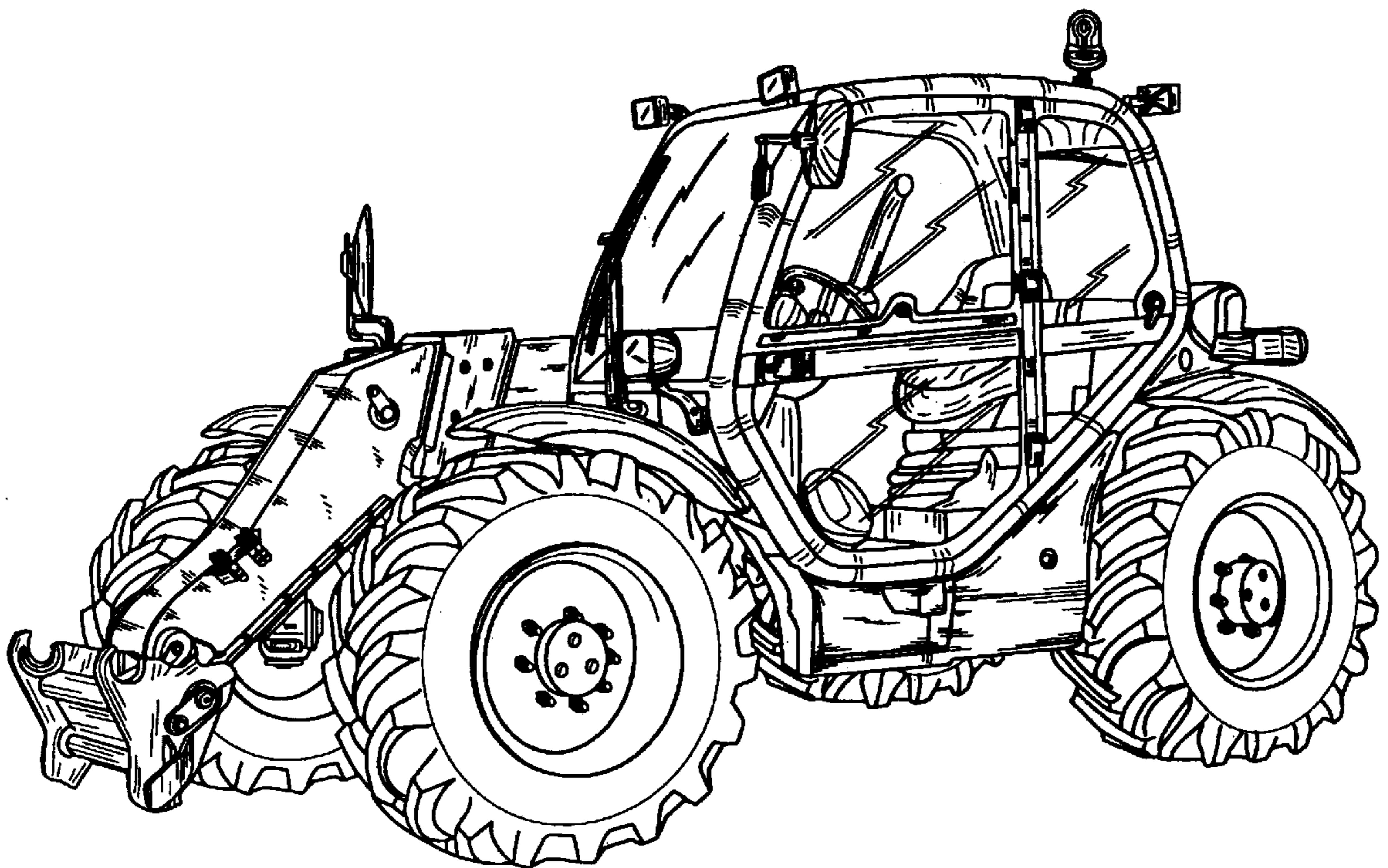

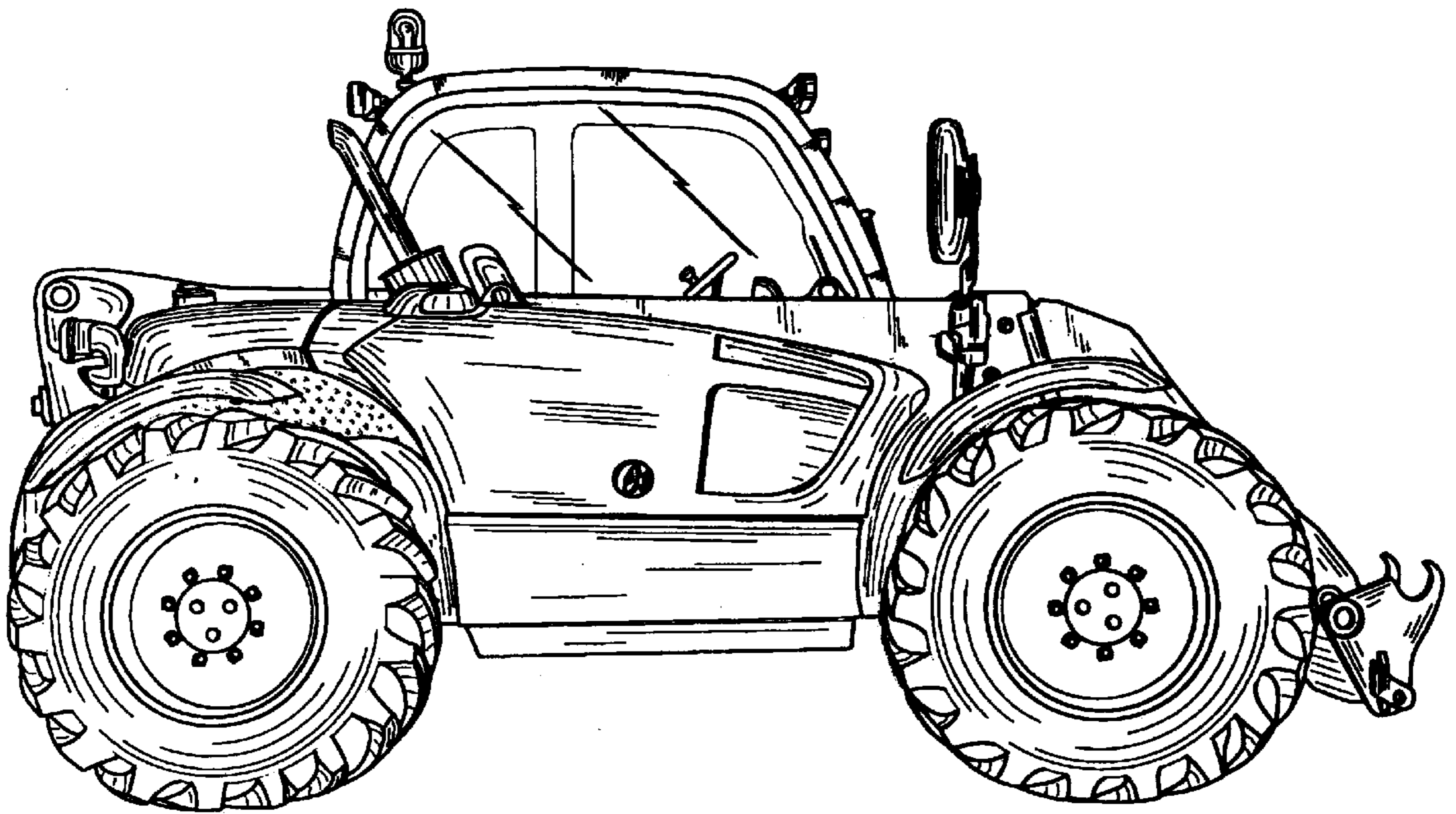

FIG. 1

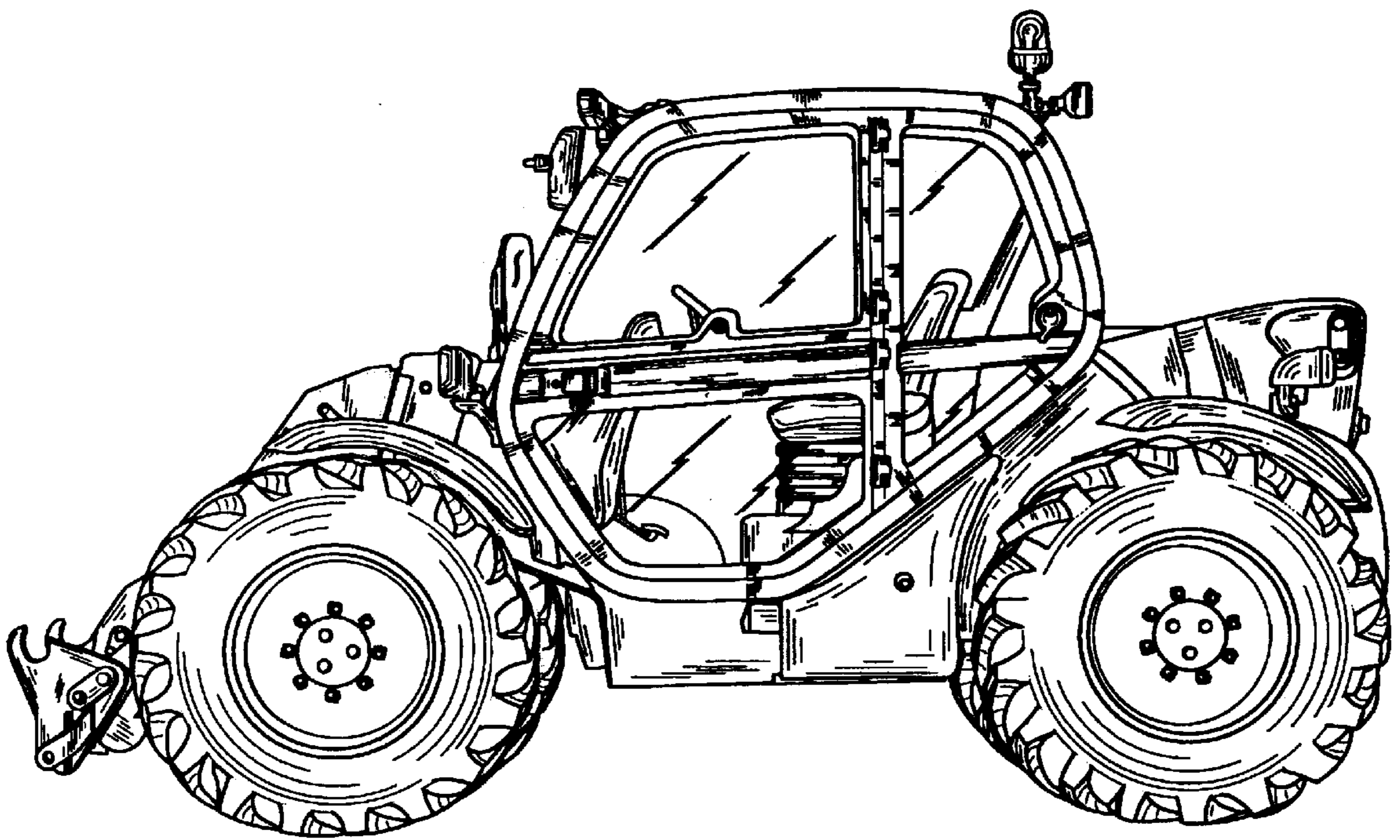

FIG. 2



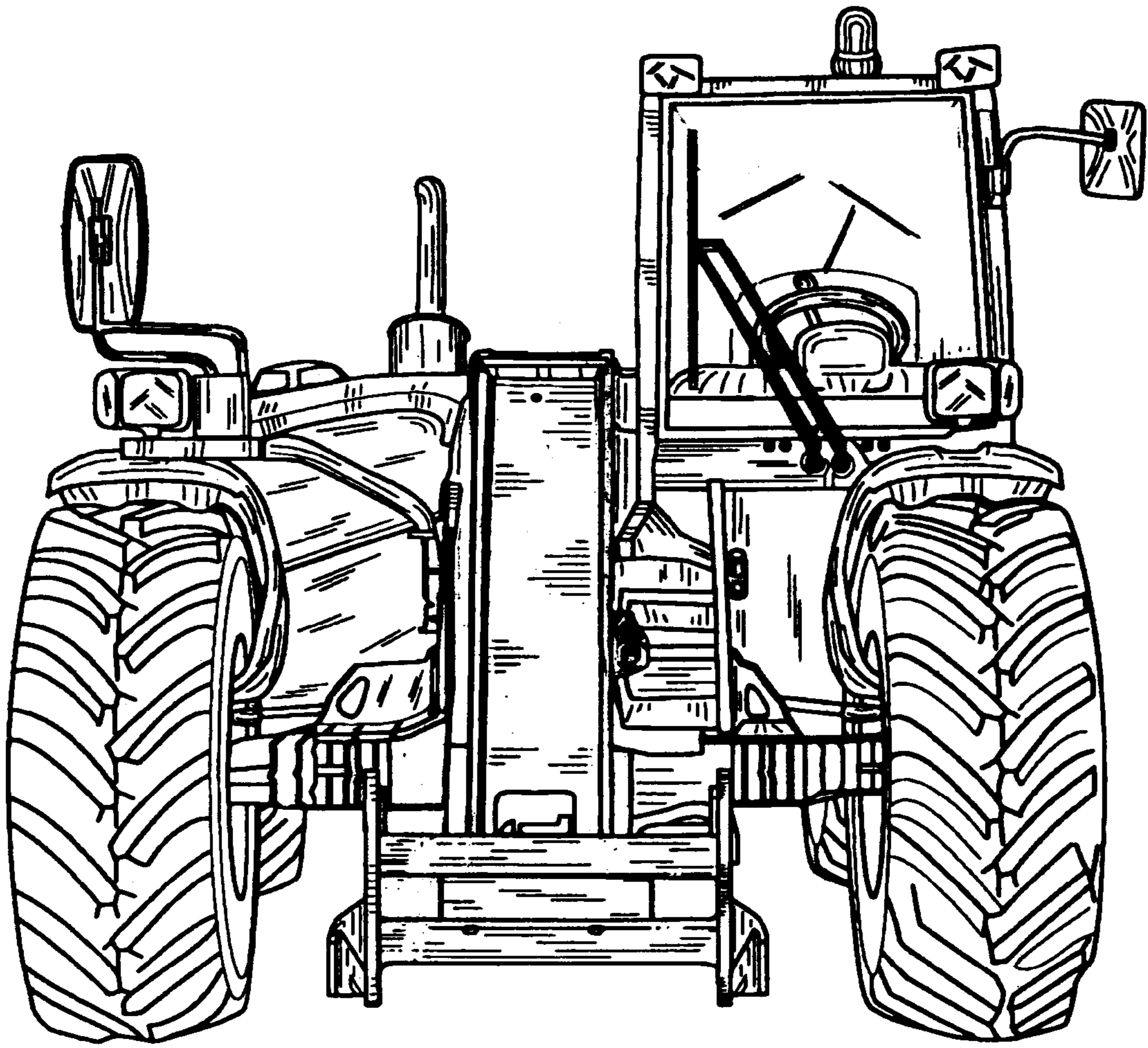

FIG. 3

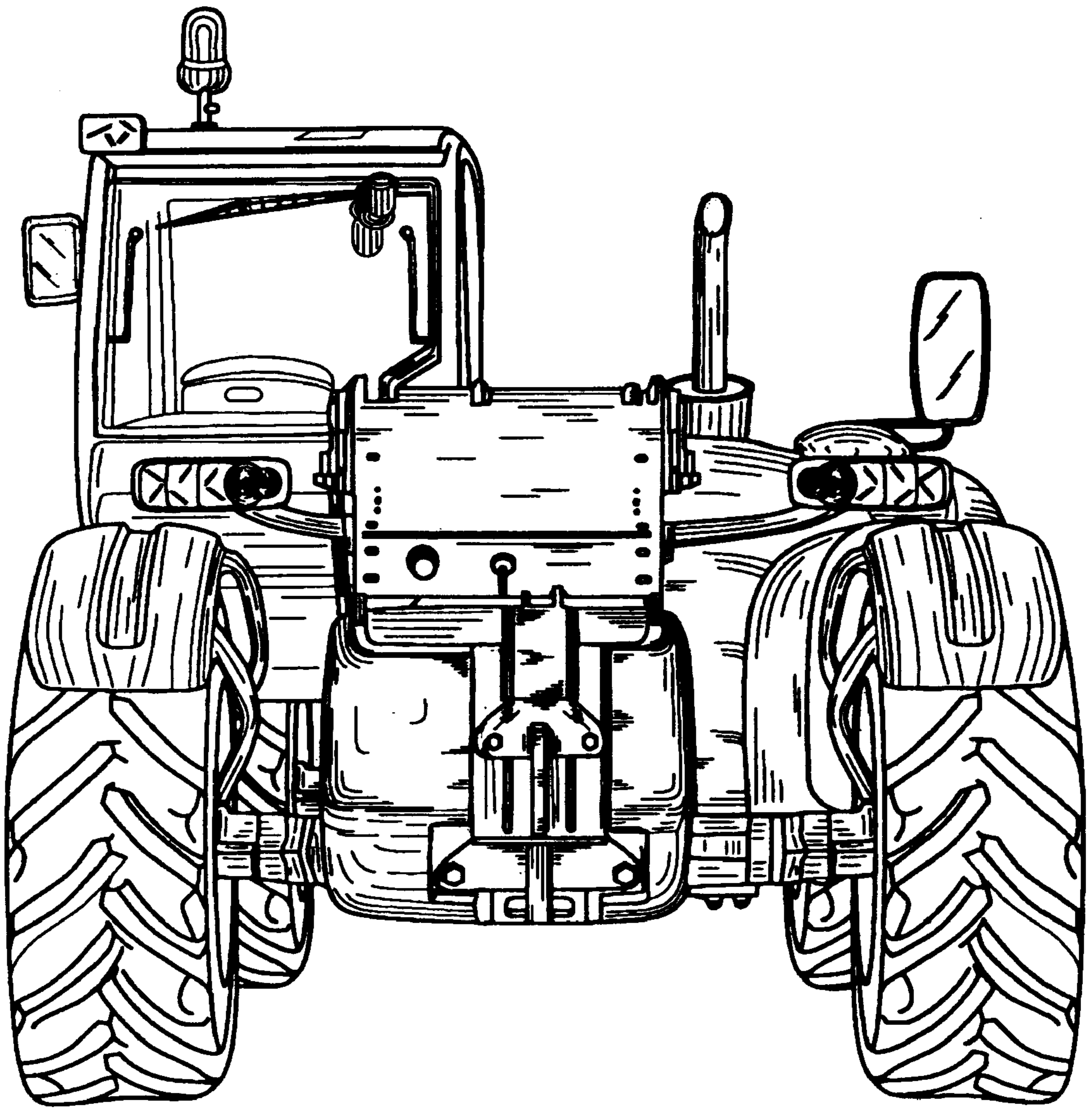

FIG. 4

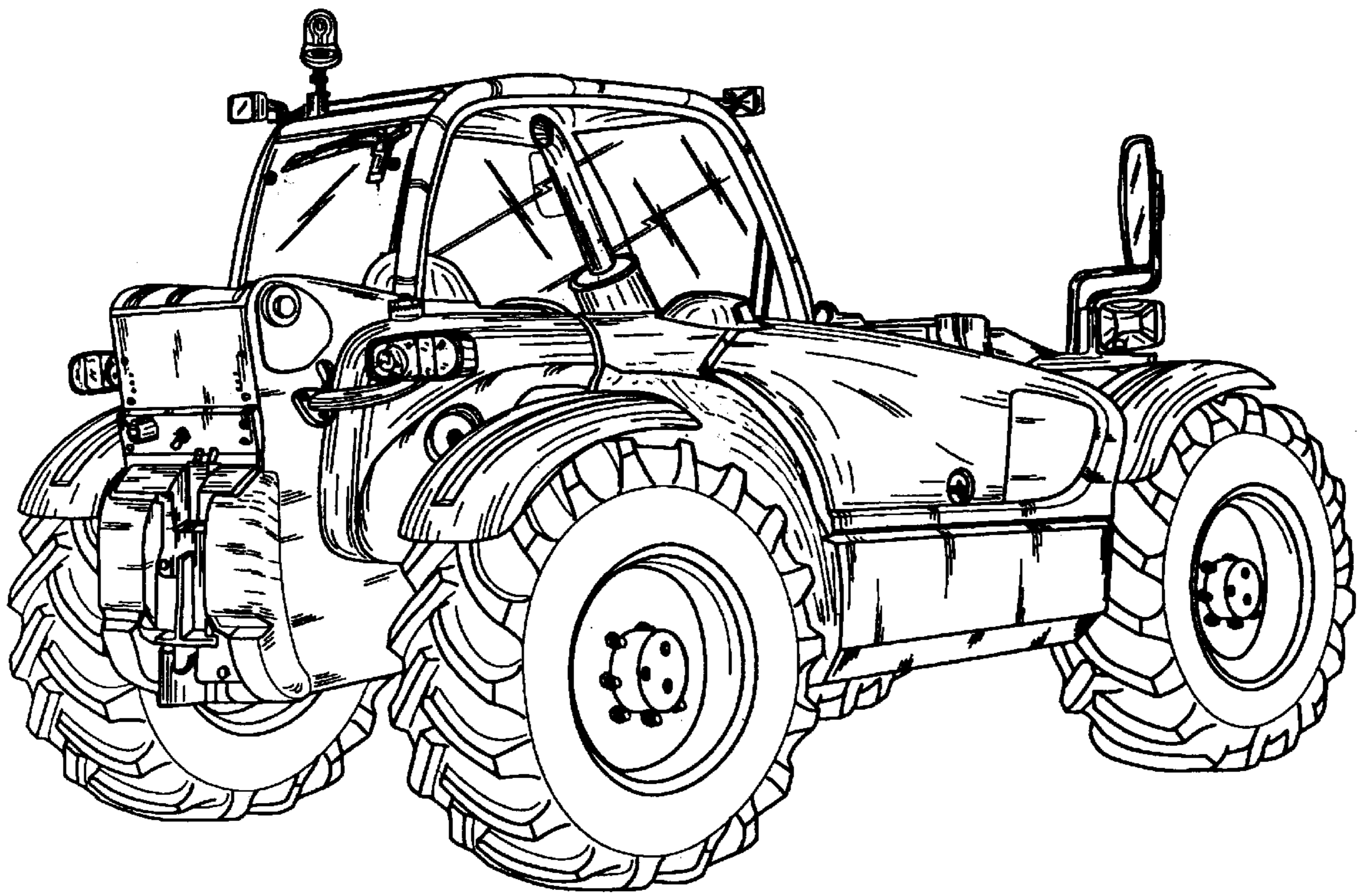

FIG. 5



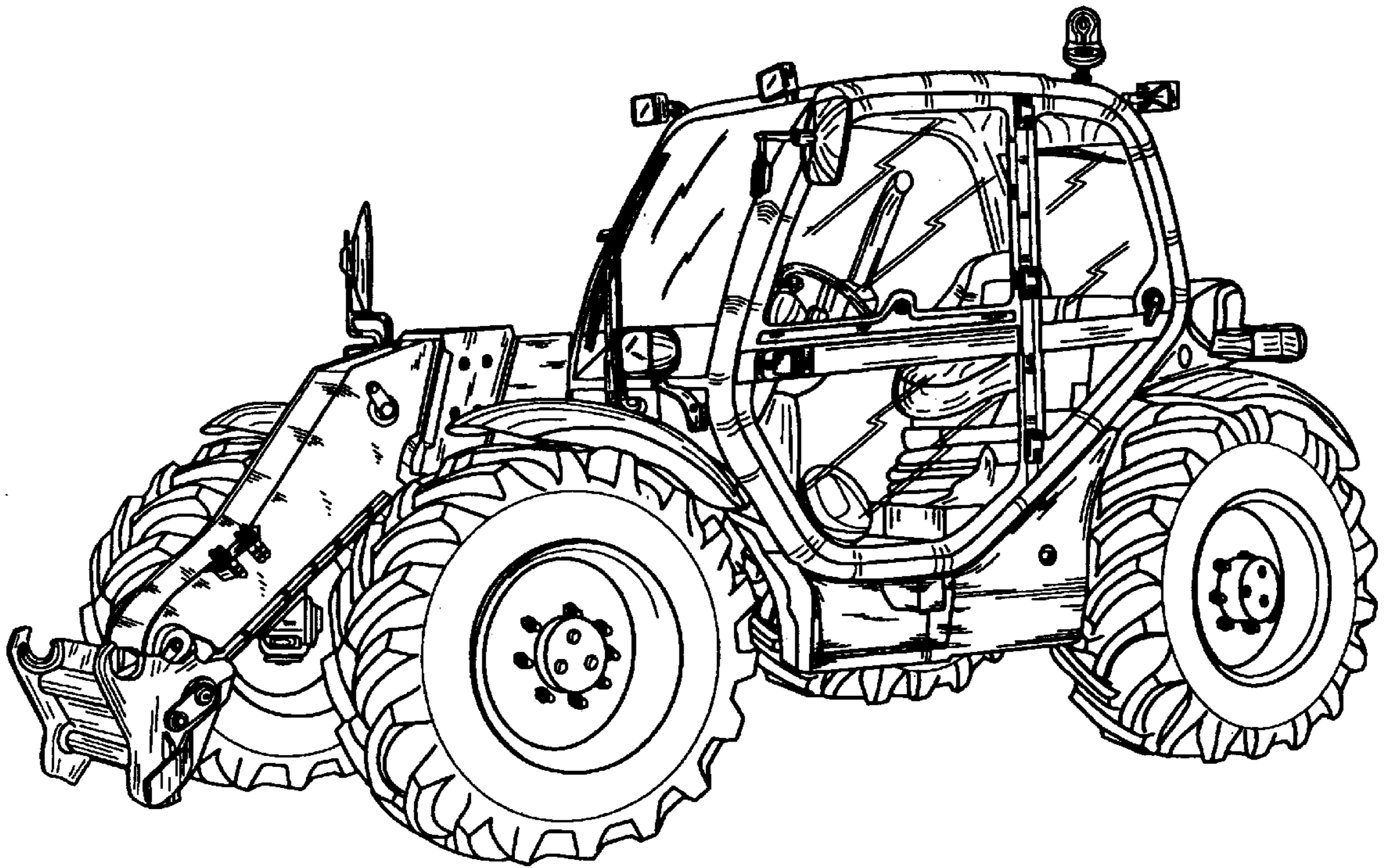

FIG. 6

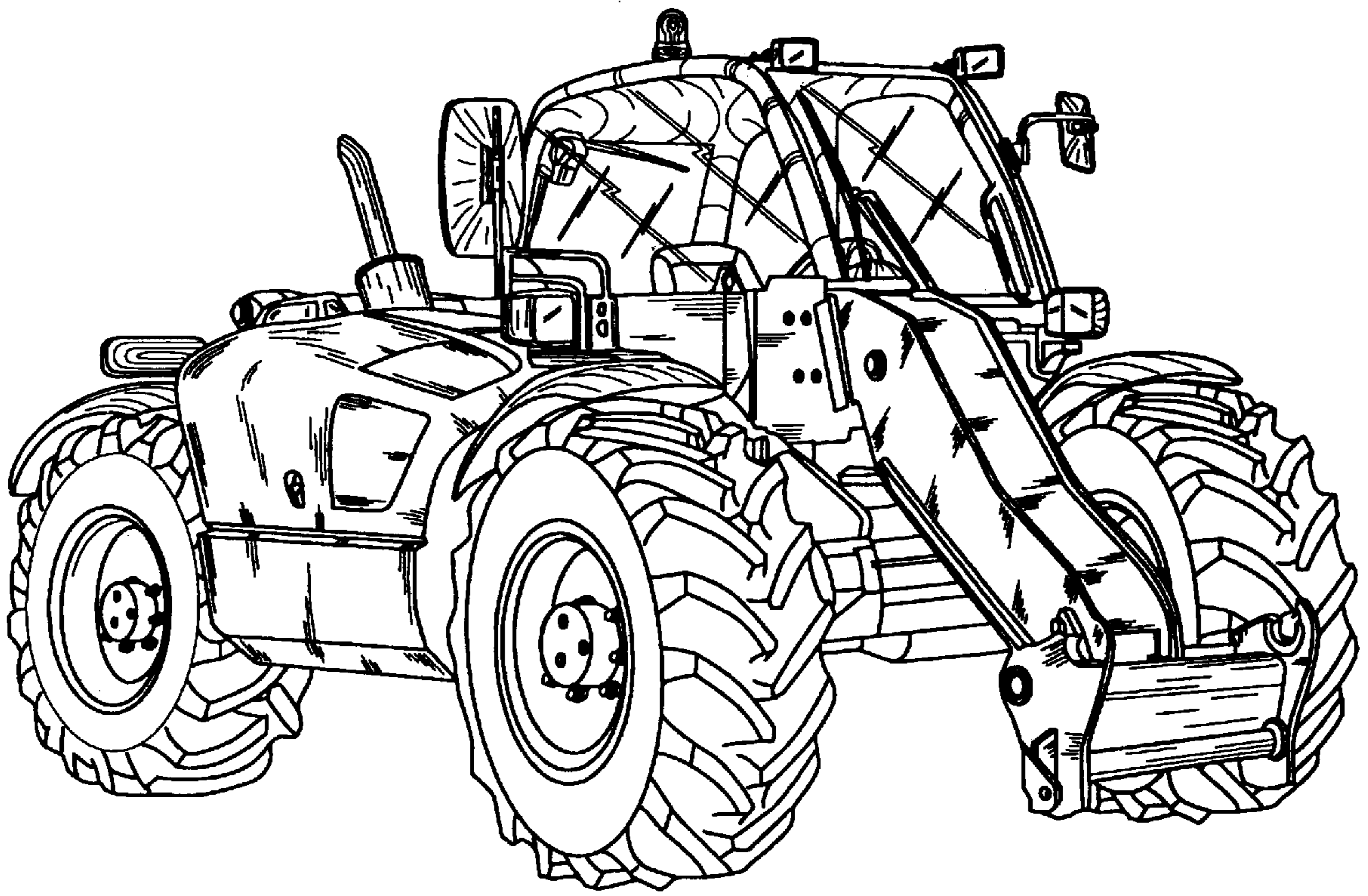

FIG. 7