



US00D438163S

(12) **United States Design Patent**
Langerer

(10) **Patent No.:** **US D438,163 S**

(45) **Date of Patent:** **** Feb. 27, 2001**

(54) **FRONT FACE OF A VEHICLE WHEEL**

(75) **Inventor:** **Marcus Langerer, Renningen (DE)**

(73) **Assignee:** **Bayerische Motoren Werke
Aktiengesellschaft, Munich (DE)**

(**) **Term:** **14 Years**

(21) **Appl. No.:** **29/120,004**

(22) **Filed:** **Mar. 13, 2000**

(30) **Foreign Application Priority Data**

Sep. 13, 1999 (DE) 4 99 08 725

(51) **LOC (7) Cl.** **12-16**

(52) **U.S. Cl.** **D12/211**

(58) **Field of Search** D12/204-211;
301/37.1, 64.1, 65

(56) **References Cited**

U.S. PATENT DOCUMENTS

- D. 239,105 * 3/1976 Siroonian D12/211
- D. 292,390 * 10/1987 Ruzzin D12/211
- D. 303,949 * 10/1989 Nakatsuka D12/211
- D. 318,256 * 7/1991 Brinkmann D12/211
- D. 353,571 * 12/1994 Braungart et al. D12/211
- D. 376,125 * 12/1996 Fikse D12/211
- D. 394,838 * 6/1998 Suprihanto D12/211
- D. 395,270 * 6/1998 Baumgartner et al. D12/211
- D. 398,898 * 9/1998 Baumgartner D12/211
- D. 399,474 * 10/1998 Stacy D12/211
- D. 405,409 * 2/1999 Baumgartner D12/211

- D. 405,749 * 2/1999 Kulla D12/211
- D. 406,092 * 2/1999 Baumgartner D12/211
- D. 410,426 * 6/1999 Frizzi D12/211
- D. 416,849 * 11/1999 Weidhase D12/211
- D. 419,948 * 2/2000 Cahyono D12/211
- D. 420,320 * 2/2000 Khoury D12/209

FOREIGN PATENT DOCUMENTS

DM/046 360 3/1999 (WO) .

* cited by examiner

Primary Examiner—Stacia Cadmus

(74) *Attorney, Agent, or Firm*—Evenson, McKeown, Edwards & Lenahan, P.L.L.C.

(57) **CLAIM**

The ornamental design for a front face of a vehicle wheel, as shown and described.

DESCRIPTION

FIG. 1 is a perspective view of a first embodiment of a front face of a vehicle wheel according to my novel design; FIG. 2 is a front view of the first embodiment of the front face of a vehicle wheel according to my novel design; FIG. 3 is a perspective view of a second embodiment of the front face of a vehicle wheel according to my novel design; and, FIG. 4 is a front view of the second embodiment of the front face of a vehicle wheel according to my novel design. The dash lines included depict environment and are not part of the claimed design.

1 Claim, 2 Drawing Sheets

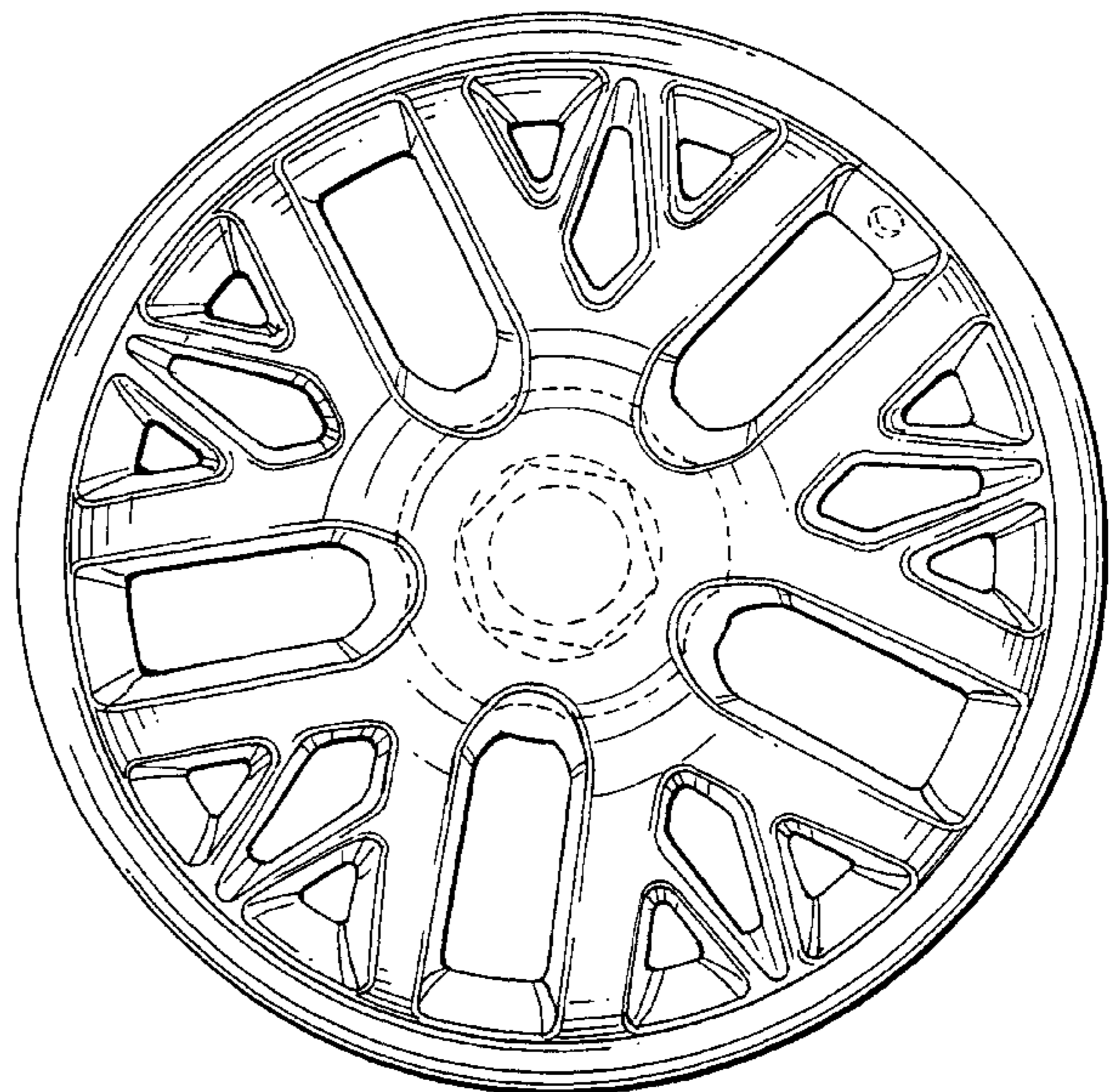
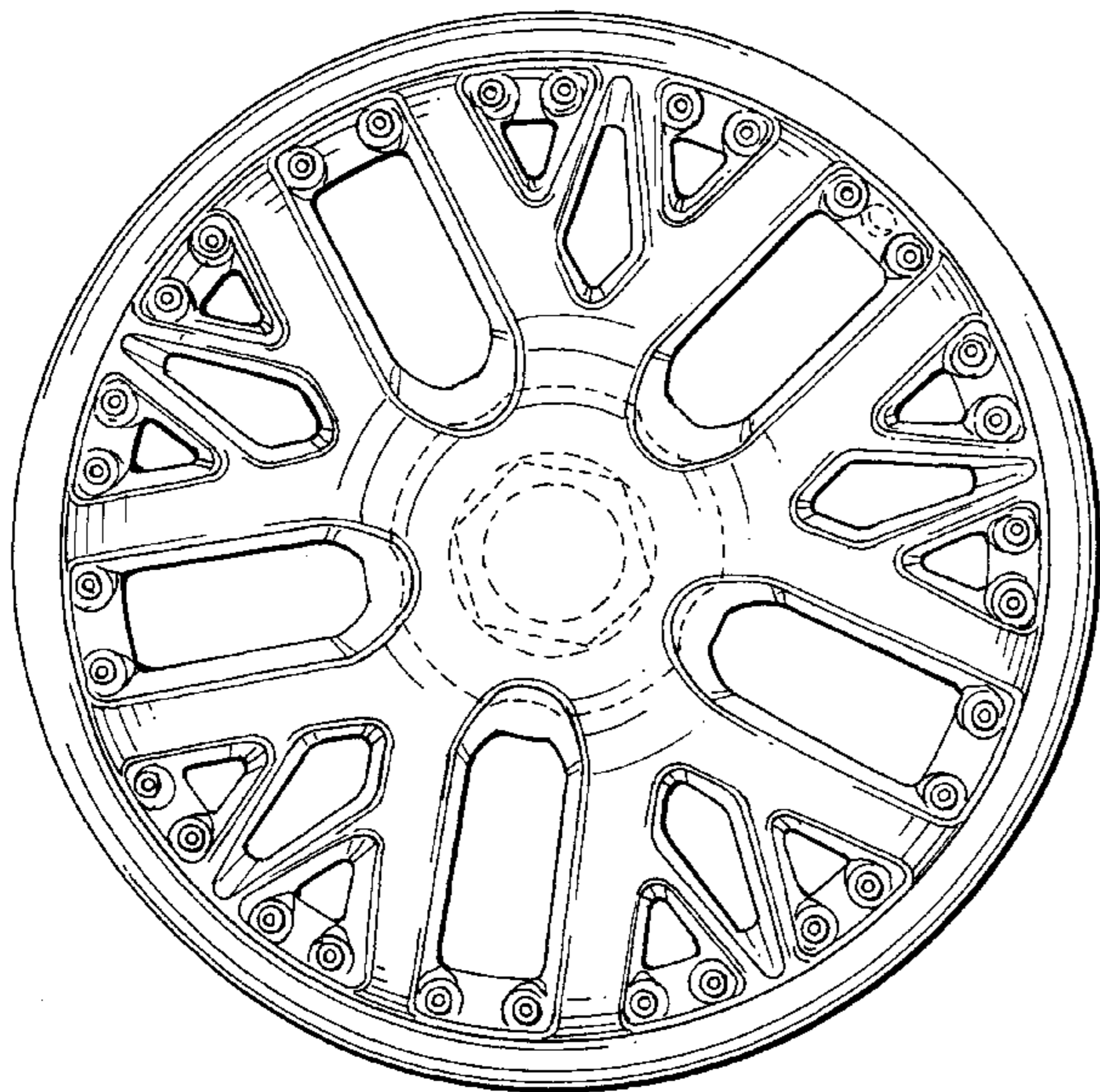

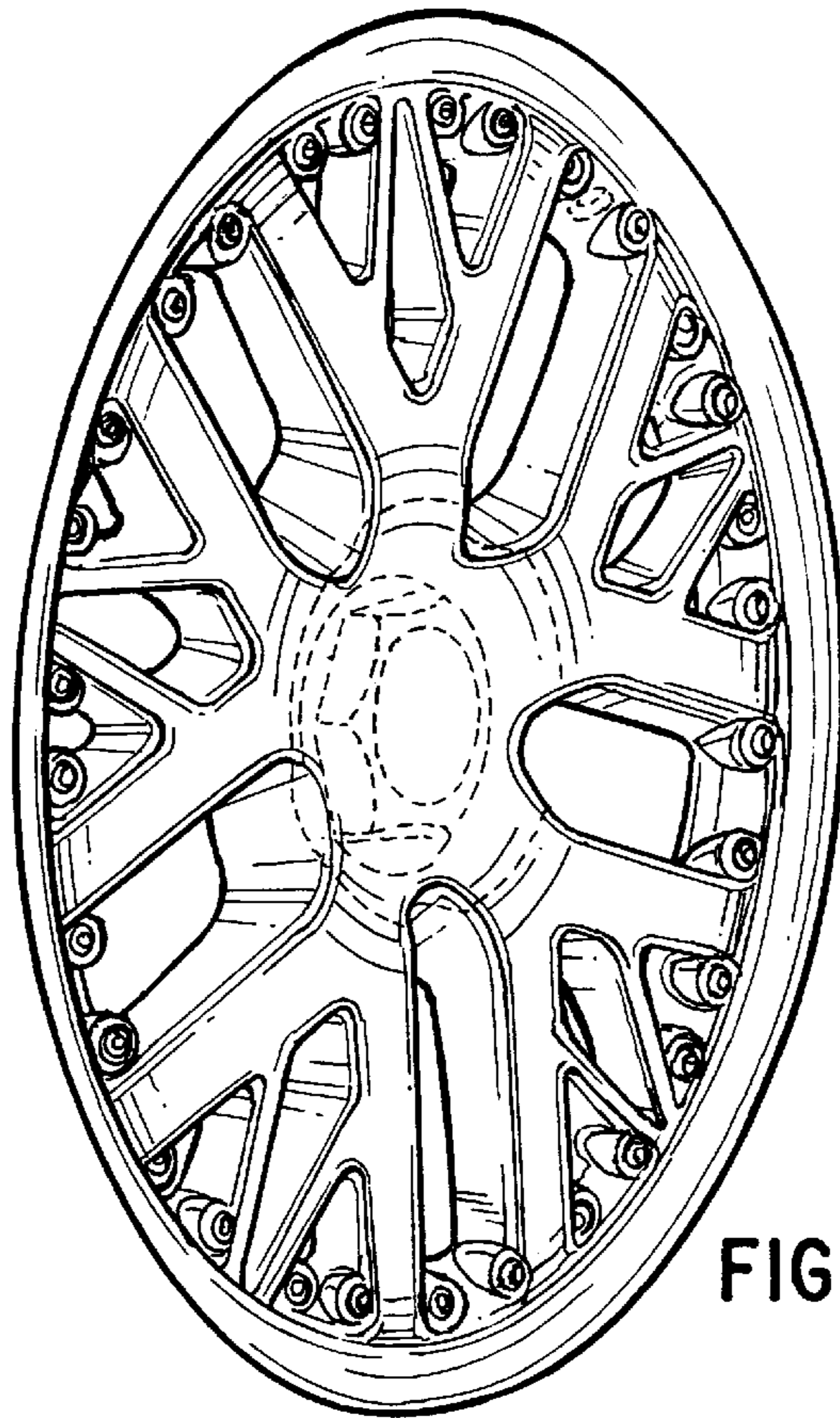

FIG. 1

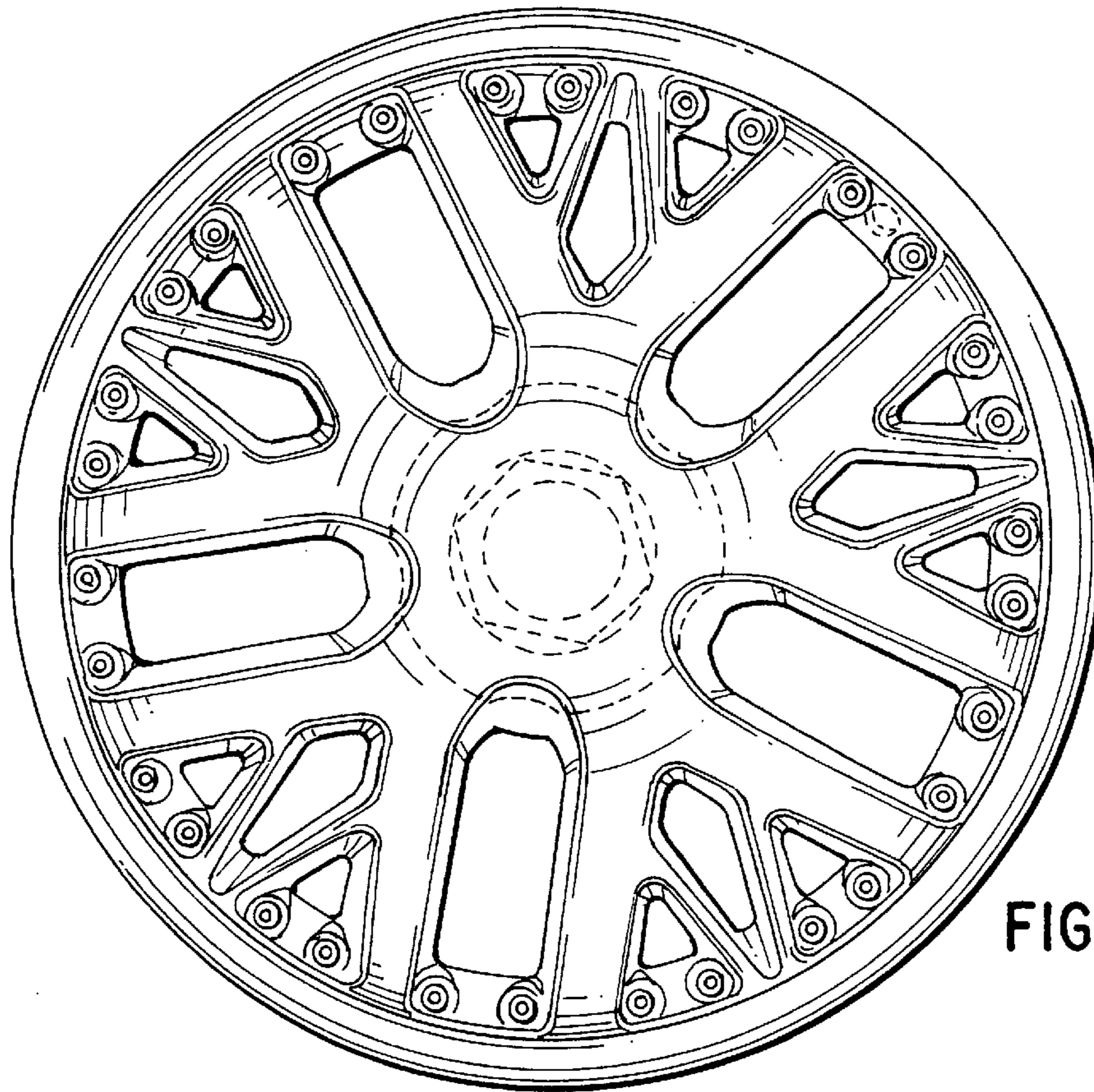

FIG. 2

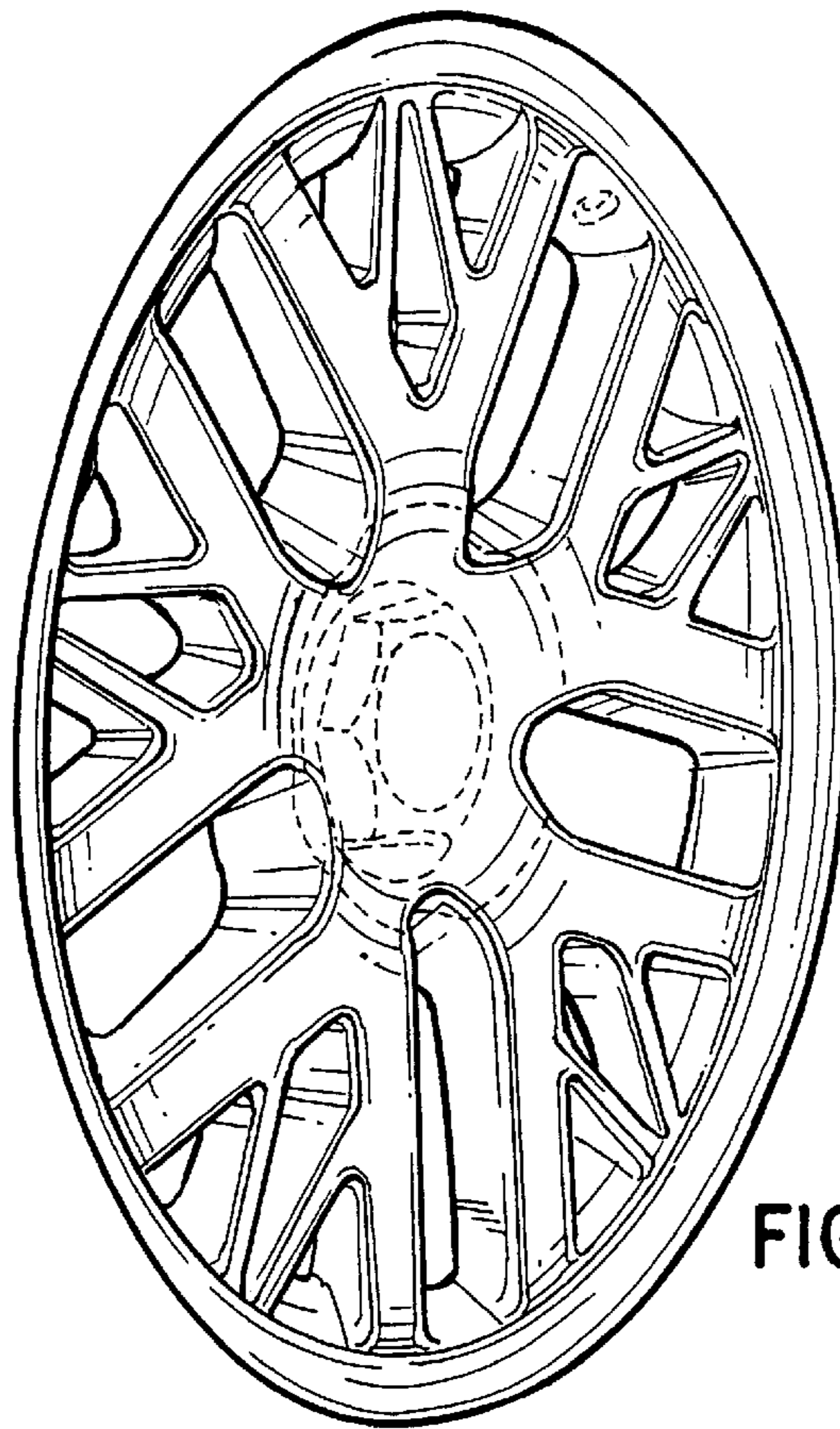

FIG. 3

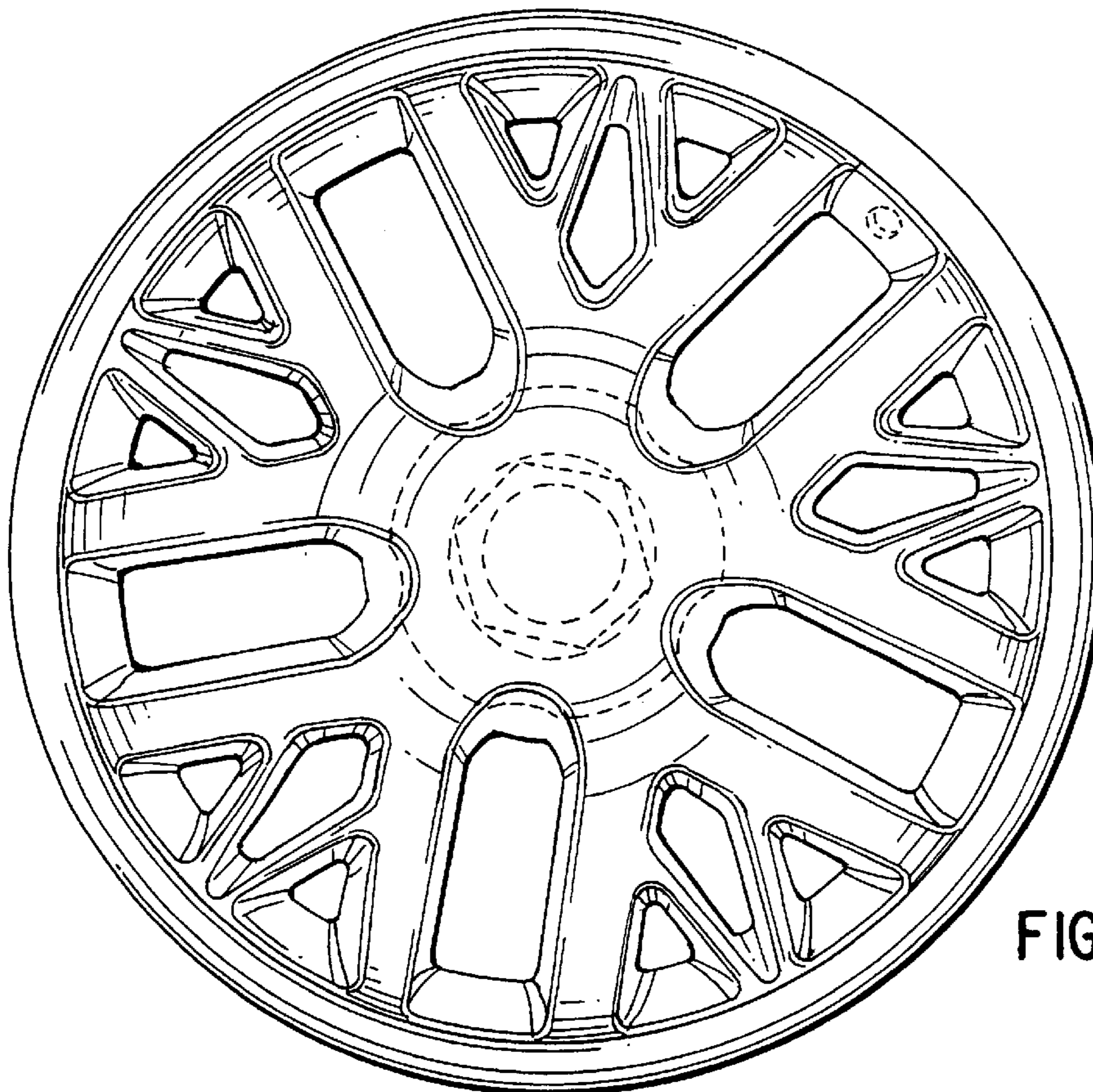

FIG. 4