



US00D438151S

(12) **United States Design Patent**
Pfeiffer

(10) **Patent No.:** **US D438,151 S**

(45) **Date of Patent:** **** Feb. 27, 2001**

(54) **FRONTAL CONFIGURATION OF A STEERING WHEEL FOR A VEHICLE**

D. 420,963 * 2/2000 Conterno D12/176
D. 424,488 * 5/2000 Thorpe D12/176

(75) **Inventor:** **Peter Pfeiffer**, Boeblingen (DE)

* cited by examiner

(73) **Assignee:** **DaimlerChrysler AG**, Stuttgart (DE)

Primary Examiner—Melody N. Brown
(74) *Attorney, Agent, or Firm*—Evenson, McKeown, Edwards & Lenahan, P.L.L.C.

(**) **Term:** **14 Years**

(21) **Appl. No.:** **29/125,940**

(22) **Filed:** **Jul. 6, 2000**

(30) **Foreign Application Priority Data**

Jan. 27, 2000 (DE) 400 00 752

(51) **LOC (7) Cl.** **12-16**

(52) **U.S. Cl.** **D12/176**

(58) **Field of Search** D12/176, 175;
74/552, 558, 558.5

(56) **References Cited**

U.S. PATENT DOCUMENTS

D. 407,359 * 3/1999 Conterno D12/176

(57) **CLAIM**

The ornamental design for a frontal configuration of a steering wheel for a vehicle, as shown and described.

DESCRIPTION

FIG. 1 is a front view of a frontal configuration of a steering wheel for a vehicle according to my novel design; and, FIG. 2 is a left perspective view of the frontal configuration of a steering wheel for a vehicle according to my novel design.

The broken lines included depict environment and are not part of the claimed design.

1 Claim, 1 Drawing Sheet

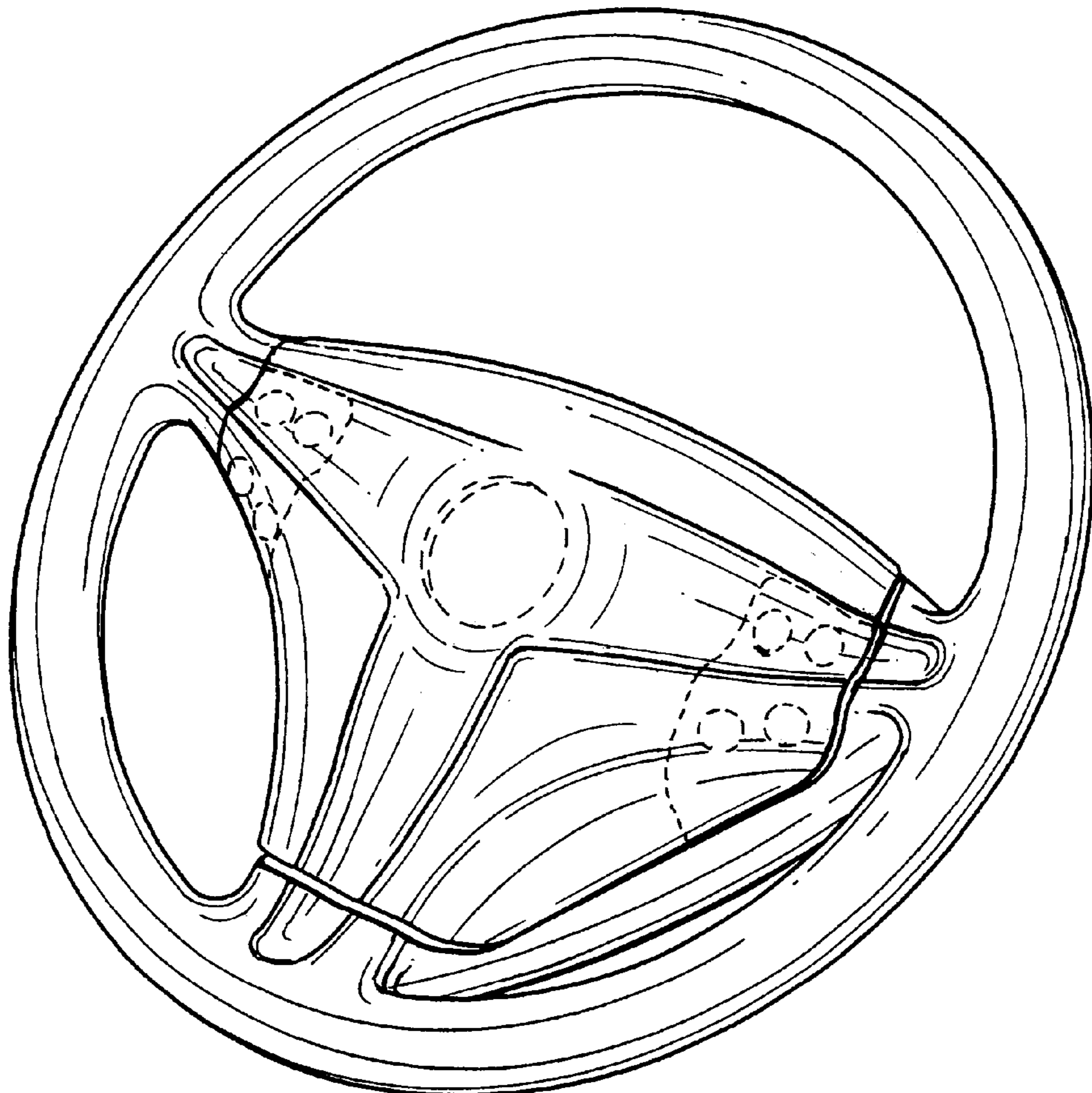

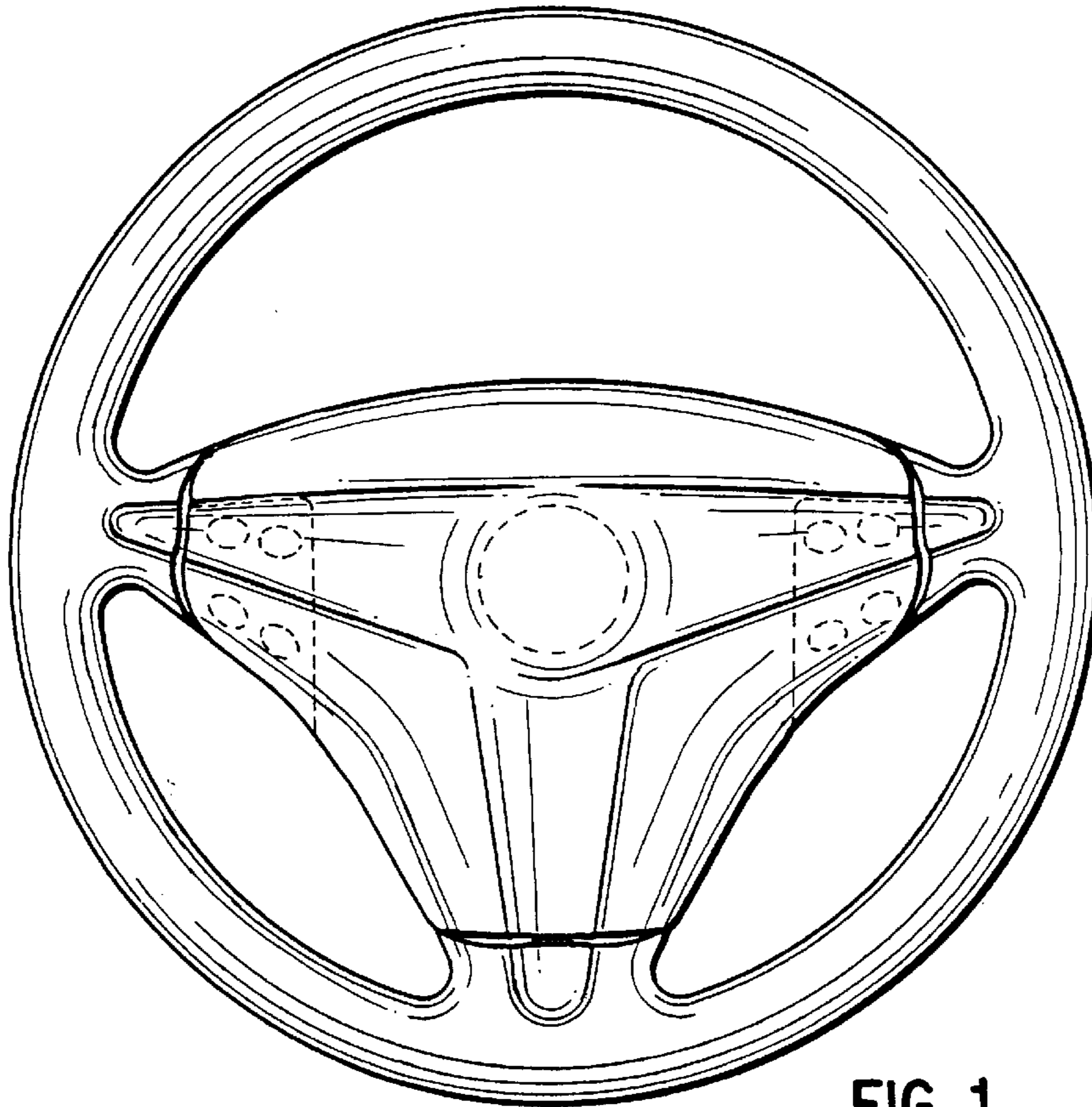

FIG. 1

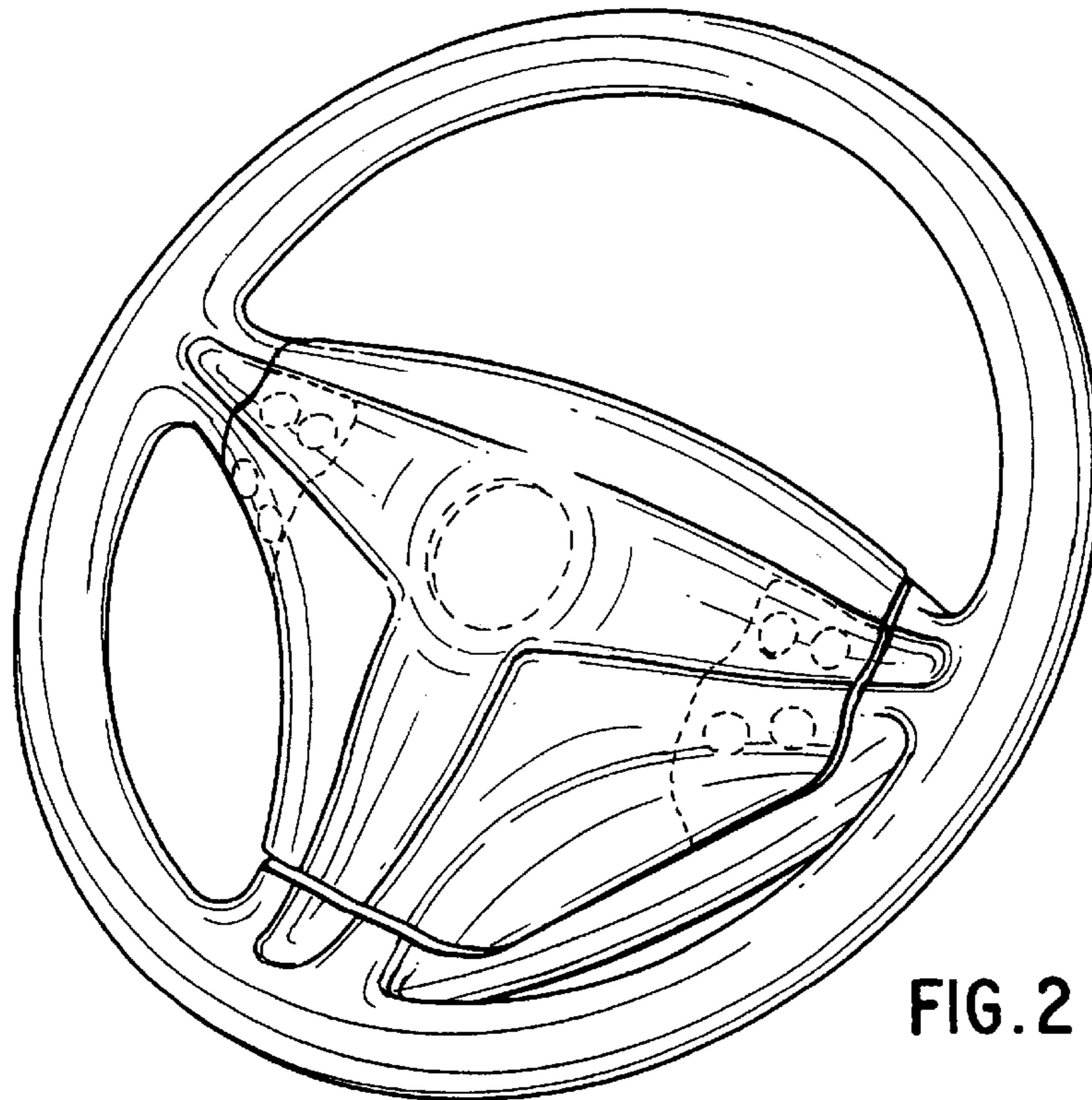

FIG. 2