



US00D437814S

(12) **United States Design Patent**
Yokomaku

(10) **Patent No.:** **US D437,814 S**

(45) **Date of Patent:** **** Feb. 20, 2001**

(54) **AUTOMOBILE BODY MOLDING KIT**

(75) Inventor: **Hironao Yokomaku**, Tsukuba (JP)

(73) Assignee: **Veilside Co., Ltd.**, Tsukuba (JP)

(**) Term: **14 Years**

(21) Appl. No.: **29/111,189**

(22) Filed: **Sep. 21, 1999**

(30) **Foreign Application Priority Data**

Mar. 23, 1999	(JP)	11-10726
Apr. 23, 1999	(JP)	11-10724
Apr. 23, 1999	(JP)	11-10725
Apr. 23, 1999	(JP)	11-10727
Apr. 23, 1999	(JP)	11-10728

(51) **LOC (7) Cl.** **12-16**

(52) **U.S. Cl.** **D12/190; D12/196**

(58) **Field of Search** **D12/190, 196,**
D12/169, 181, 184, 203, 90-92; 296/192-197,
180.1

(56) **References Cited**

U.S. PATENT DOCUMENTS

D. 293,311	*	12/1987	Strosek	D12/169
D. 310,506		9/1990	Fioravanti	D12/196
D. 311,512		10/1990	Fioravanti	D12/196
D. 333,118	*	2/1993	Stauffer	D12/190
D. 366,638		1/1996	Tucker et al.	D12/173
D. 373,331	*	9/1996	Ohkura et al.	D12/91
D. 377,160		1/1997	Murkett	D12/181
D. 389,095	*	1/1998	Stollery	D12/91
D. 401,199		11/1998	Kovach et al.	D12/181
D. 402,319		12/1998	Fu	D12/91
D. 402,922	*	12/1998	Singer et al.	D12/92
D. 404,350		1/1999	Mobley	D12/181
D. 404,691	*	1/1999	Gerisch et al.	D12/92
D. 406,548		3/1999	Ramaciotti	D12/91
D. 413,561	*	9/1999	Kulla et al.	D12/190
D. 418,088	*	12/1999	Fioravanti	D12/92
D. 430,508	*	9/2000	Crain et al.	D12/92

OTHER PUBLICATIONS

- Veilside Co., Ltd., "Veilside Catalog vol. 1," 1993.
- Veilside Co., Ltd., "Veilside Catalog vol. 2," 1994.
- Veilside Co., Ltd., "Veilside Catalog vol. 3," 1995.
- Veilside Co., Ltd., "Veilside Catalog vol. 4," 1996.
- Veilside Co., Ltd., "Veilside Design Folder—Catalog vol. 5," 1997.
- Veilside Co., Ltd., "Carstyling 128," 1999.
- "Auto & Parts Magazine," Oct., 1992, p. 109.
- "Car and Leisure for the Young," Feb., 1993, p. 254.
- "Option 2" magazine, Feb., 1994, pp. 12-13 and four unnumbered pages.
- "CARisma" magazine, No. 11, May, 1994, p. 29.
- "CARisma" magazine, No. 13, Jul., 1994, 1 pg.
- "Auto Fashion" magazine, Jan., 1995, 1 pg.
- "Option Communication Car Magazine," Feb., 1995, pp. 12-13.
- "Auto & Parts Magazine," Mar., 1995 pp. 26-29.

(List continued on next page.)

Primary Examiner—Melody N. Brown

(74) *Attorney, Agent, or Firm*—Oliff & Berridge, PLC

(57) **CLAIM**

The ornamental design for an automobile body molding kit, as shown and described.

DESCRIPTION

FIG. 1 is a front perspective view of an automobile having the body molding kit according to my novel design;
 FIG. 2 is a rear perspective view thereof;
 FIG. 3 is a front view thereof;
 FIG. 4 is a rear view thereof;
 FIG. 5 is a left side view thereof;
 FIG. 6 is a right side view thereof; and,
 FIG. 7 is a top view thereof.

The broken line showing of an automobile is for illustrative purposes only and forms no part of the claimed design.

1 Claim, 6 Drawing Sheets

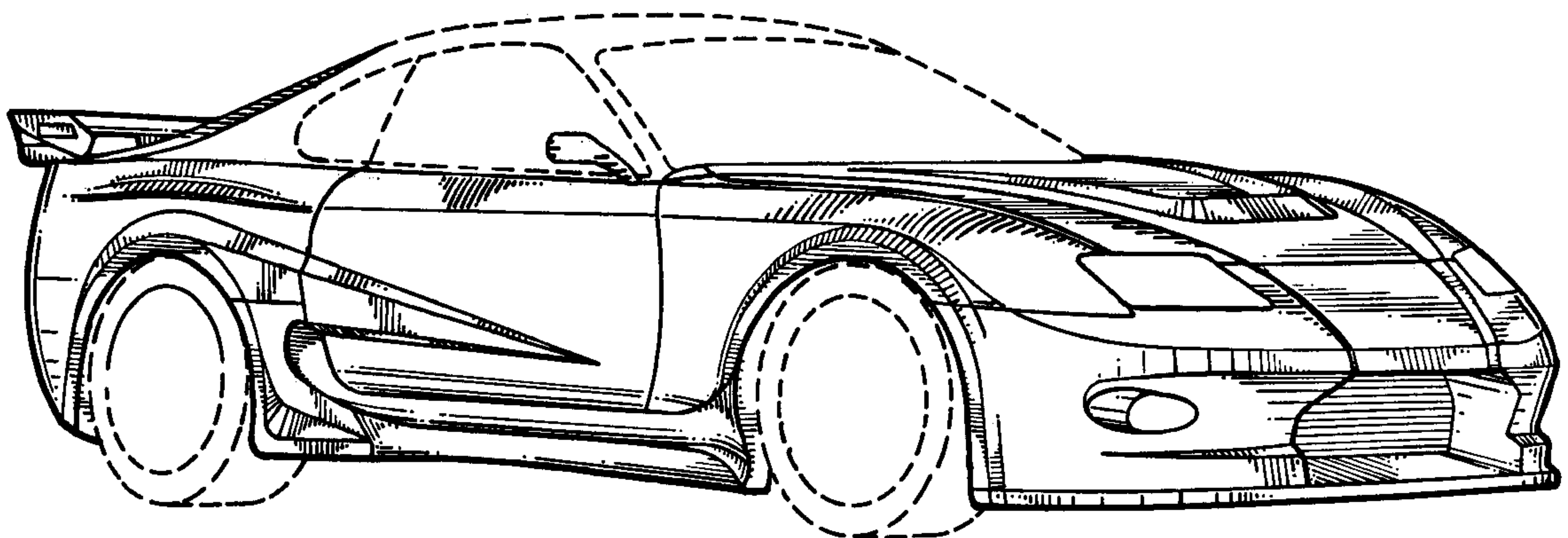

OTHER PUBLICATIONS

“Option Communication Car Magazine,” Mar., 1995, p. 343.

“Auto” magazine, Sep., 1995, 2 pgs.

“Panda: Parts & Automobiles Magazine,” vol. 27, Dec., 1995, p. 106.

“Car and Leisure for the Young” magazine, Feb., 1996, pp. 200, 204–205 and two unnumbered pages.

“Panda: Parts & Automobiles Magazine,” vol. 29, Feb., 1996, pp. 24–25.

“Auto” magazine, Mar., 1996, 1 pg.

“Auto” magazine, Jun., 1996, p. 106.

“Auto” magazine, Nov., 1996, 2 pgs.

“VIP Car” magazine, vol. 9, Dec., 1996, pp. 22–23 and two unnumbered pages.

“Let’s Enjoy the Exciting Carlife!” magazine, Jan., 1997, pp. 215–216.

“Option” magazine, Feb., 1997, pp. 26–27.

“Auto” magazine, Mar., 1997, 3 pgs.

“Option Communication Car Magazine,” Oct., 1997, p. 84.

“Let’s Enjoy the Exciting Carlife!” magazine, Nov., 1997, 2 pgs.

“Option Communication Car Magazine,” Dec., 1997, p. 8 and one unnumbered page.

“Auto Moda” magazine, Mar., 1998, 1 pg.

“Sport Compact Car” magazine, May, 1998, vol. 10, No. 5, pp. 100, 164, 194–195.

“Super Street” magazine, May, 1998, p. 82.

“Auto Moda” magazine, Jun., 1998, p. 130 and two unnumbered pages.

“CARisma” magazine, Dec., 1998, pp. 88, 198–199.

“Young Auto” magazine, vol. 222, Mar., 1999, pp. 13–14, 36–40–41.

“Option Communication Car Magazine,” Mar., 1999, 2 pgs.

“CARisma” magazine, Apr., 1999, pp. 24–25 and one unnumbered page.

Spoiler advertisement by TC Spoilers, Inc. of El Monte, CA, 1 pg.

Aero Jacket advertisement by VIS Racing Sports of Monterey Park, CA, 1 pg.

Advertisement for Cyber Sports Aerokits by Racing Zone Auto House, Inc. of Tampa, FL, 1 pg.

Body Styling advertisement by Nopi, 2 pgs.

Advertisement for Veilside Style Kits in “Sport Compact Car” magazine, Dec., 1998, p. 262.

Advertisement for Erebuni Aerodynamics by Erebuni Corp. of Brooklyn, NY, 4 pgs.

* cited by examiner

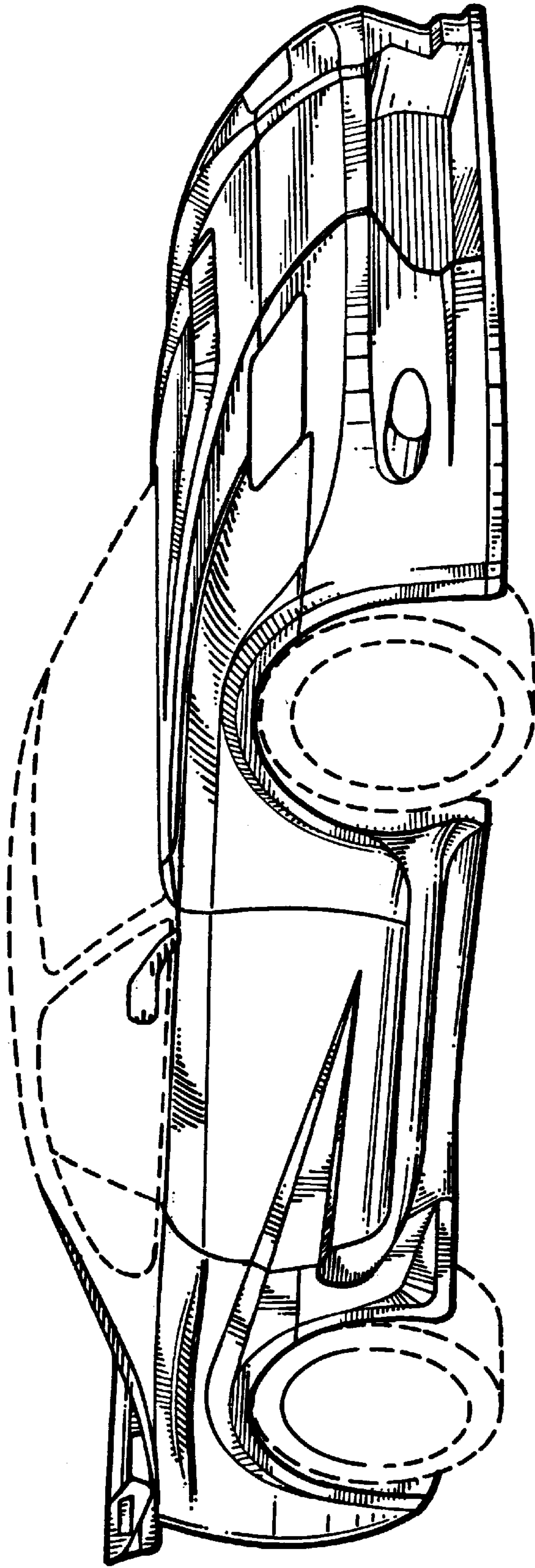

FIG. 1

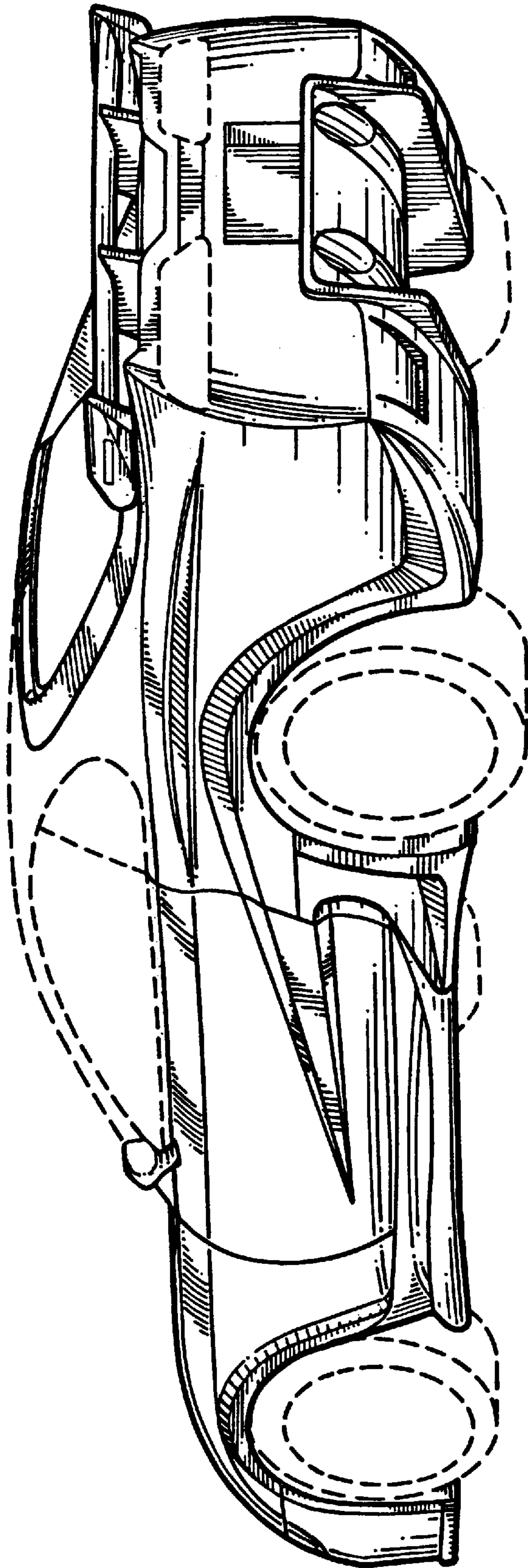

FIG. 2

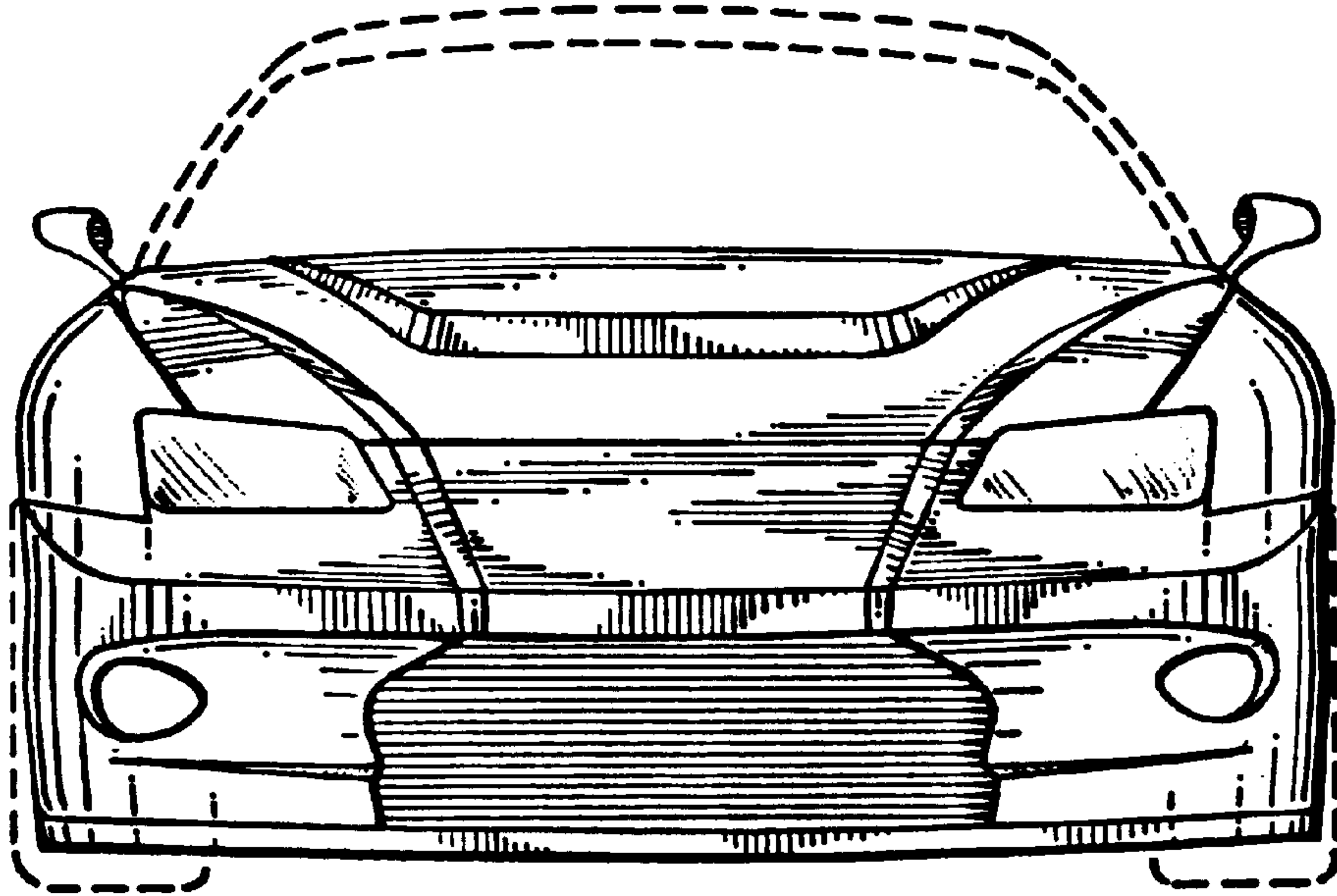

FIG.3

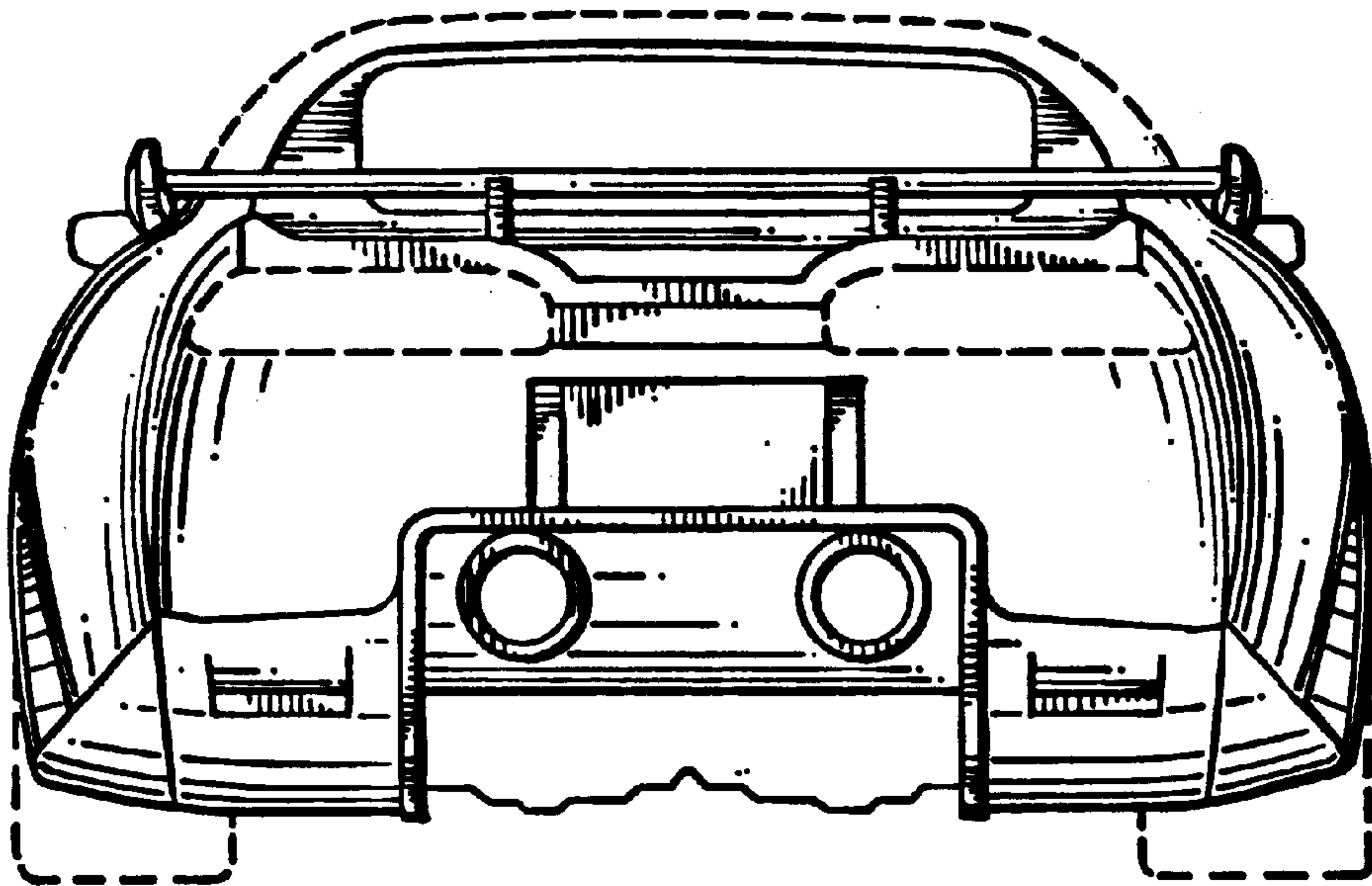

FIG.4

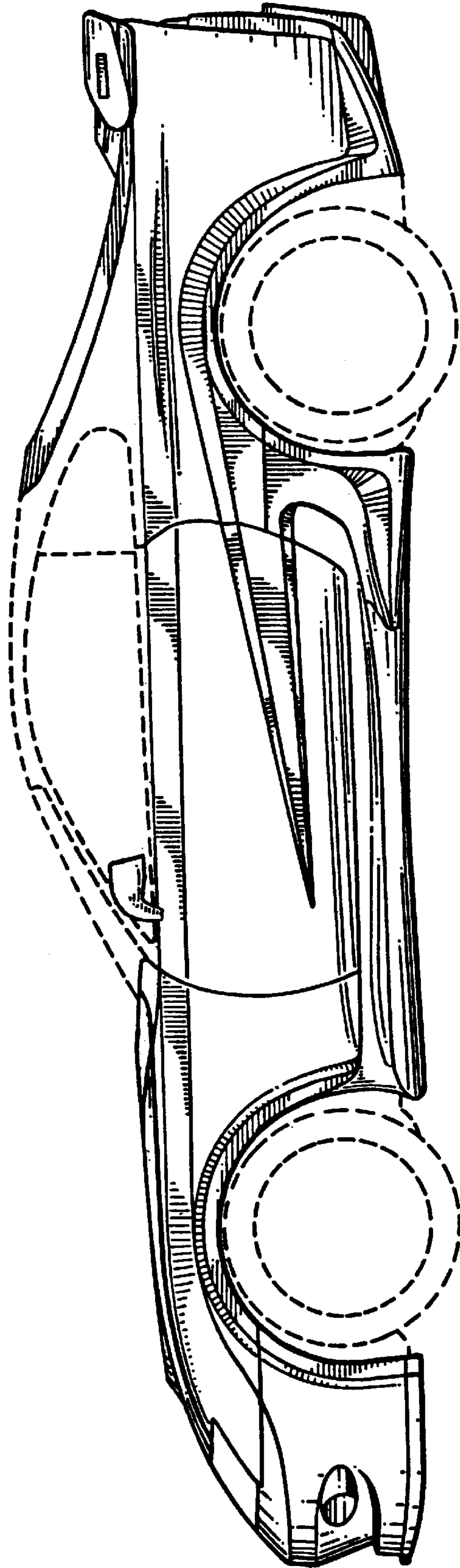

FIG. 5

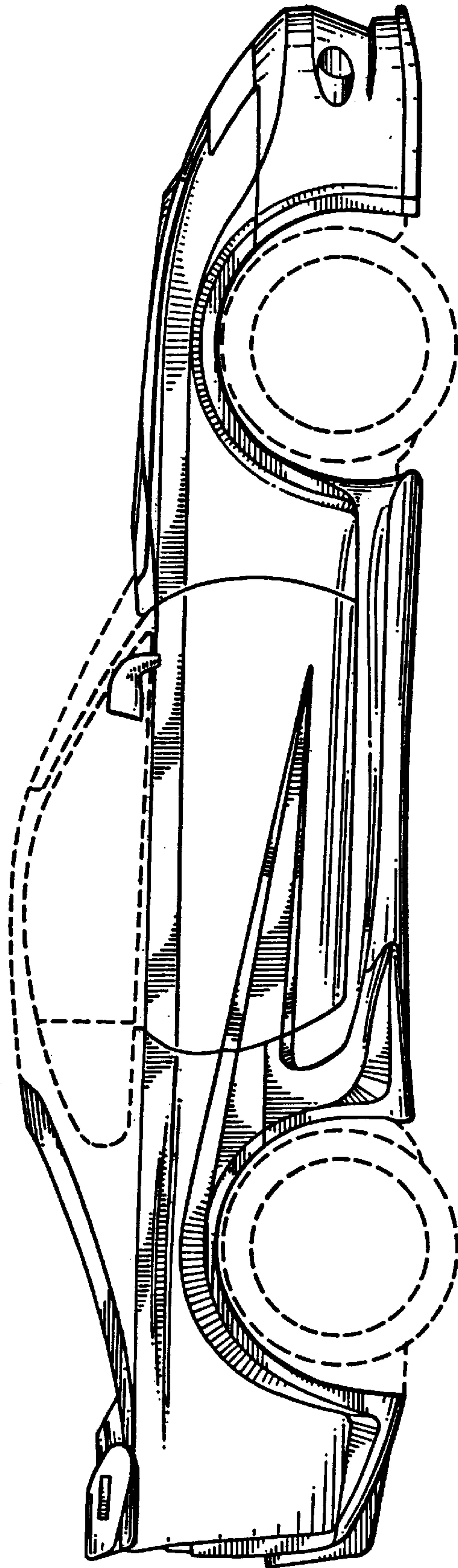

FIG. 6

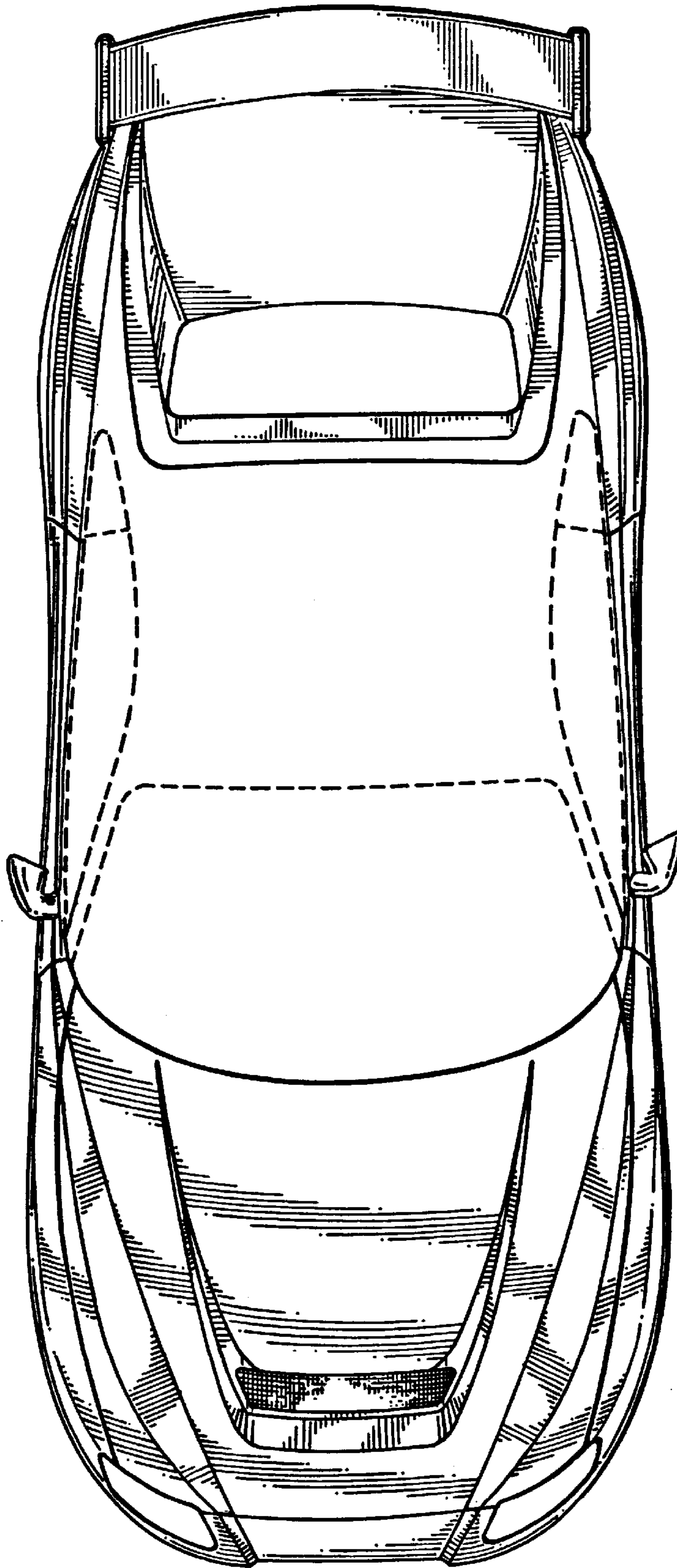

FIG. 7