



US00D437813S

(12) **United States Design Patent**
Terasawa

(10) **Patent No.:** **US D437,813 S**

(45) **Date of Patent:** **** Feb. 20, 2001**

(54) **DISC BRAKE CALIPER**

1025215 11/1998 (JP) .

1025221 11/1998 (JP) .

1025305 11/1998 (JP) .

(75) Inventor: **Youko Terasawa, Sakai (JP)**

(73) Assignee: **Shimano Inc., Osaka (JP)**

* cited by examiner

(**) Term: **14 Years**

Primary Examiner—Melody N. Brown

(74) *Attorney, Agent, or Firm*—Shinju Global IP Counselors, LLP

(21) Appl. No.: **29/119,311**

(22) Filed: **Feb. 29, 2000**

(57) **CLAIM**

(51) **LOC (7) Cl.** **12-16**

The ornamental design for a disc brake caliper, as shown and described.

(52) **U.S. Cl.** **D12/180**

(58) **Field of Search** **D12/180; 180/71.1, 180/73.1, 73.45**

DESCRIPTION

(56) **References Cited**

U.S. PATENT DOCUMENTS

D. 373,340	*	9/1996	Sands	D12/180
D. 378,363	*	3/1997	Sin	D12/180
D. 413,292	*	8/1999	Jones	D12/180
D. 426,180	*	6/2000	Pink et al.	D12/180
5,181,588	*	1/1993	Emmons	188/71.1

FIG. 1 is an inside perspective view of a disc brake caliper in accordance with my new design;

FIG. 2 is an outside elevational view of the disc brake caliper illustrated in FIG. 1;

FIG. 3 is an outer edge elevational view of the disc brake caliper illustrated in FIGS. 1 and 2;

FIG. 4 is an inside elevational view of the disc brake caliper illustrated in FIGS. 1-3;

FIG. 5 is an inner edge elevational view of the disc brake caliper illustrated in FIGS. 1-4;

FIG. 6 is a first end edge elevational view of the disc brake caliper illustrated in FIGS. 1-5; and,

FIG. 7 is a second end edge elevational view of the disc brake caliper illustrated in FIGS. 1-6.

The broken line showing of environment (the bolts, the friction pads, the bleed nipple and the brake line) in the Figures is for illustrative purposes only and forms no part of the claimed design.

FOREIGN PATENT DOCUMENTS

717606	11/1987	(JP) .
488538	7/1992	(JP) .
776197	8/1992	(JP) .
860062	1/1993	(JP) .
860063	1/1993	(JP) .
860064	1/1993	(JP) .
953750	5/1996	(JP) .
953751	5/1996	(JP) .
953766	5/1996	(JP) .

1 Claim, 3 Drawing Sheets

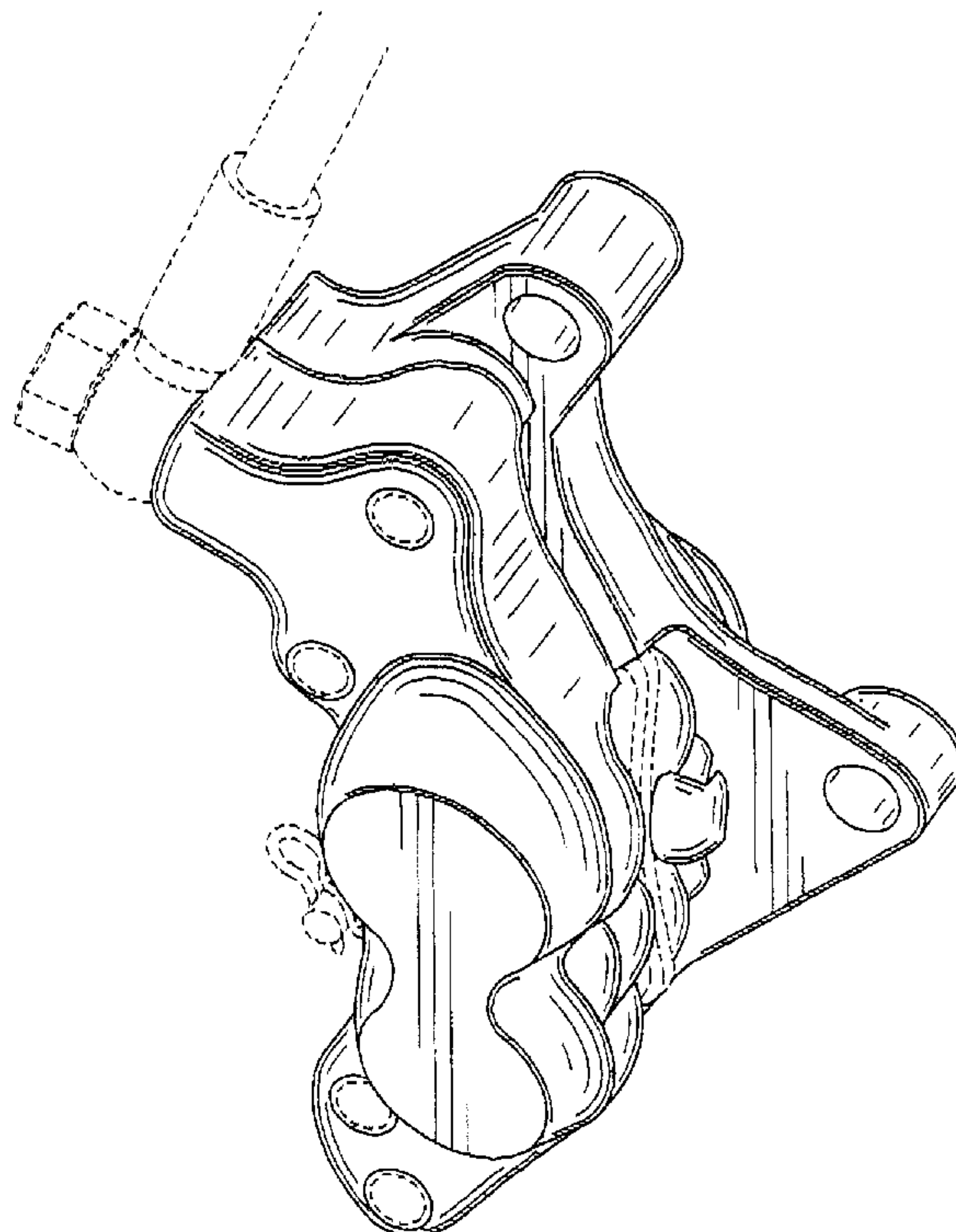

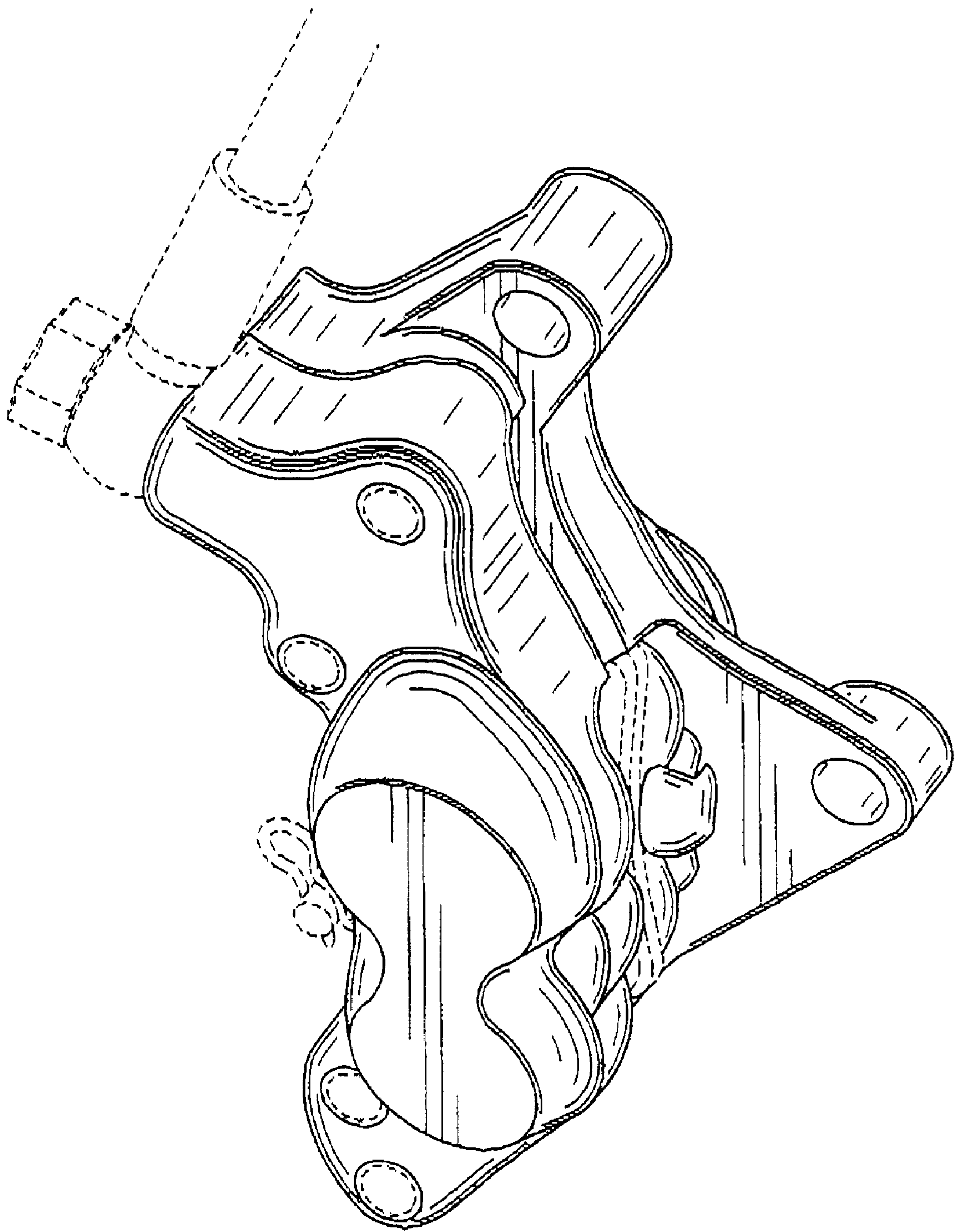

FIG. 1

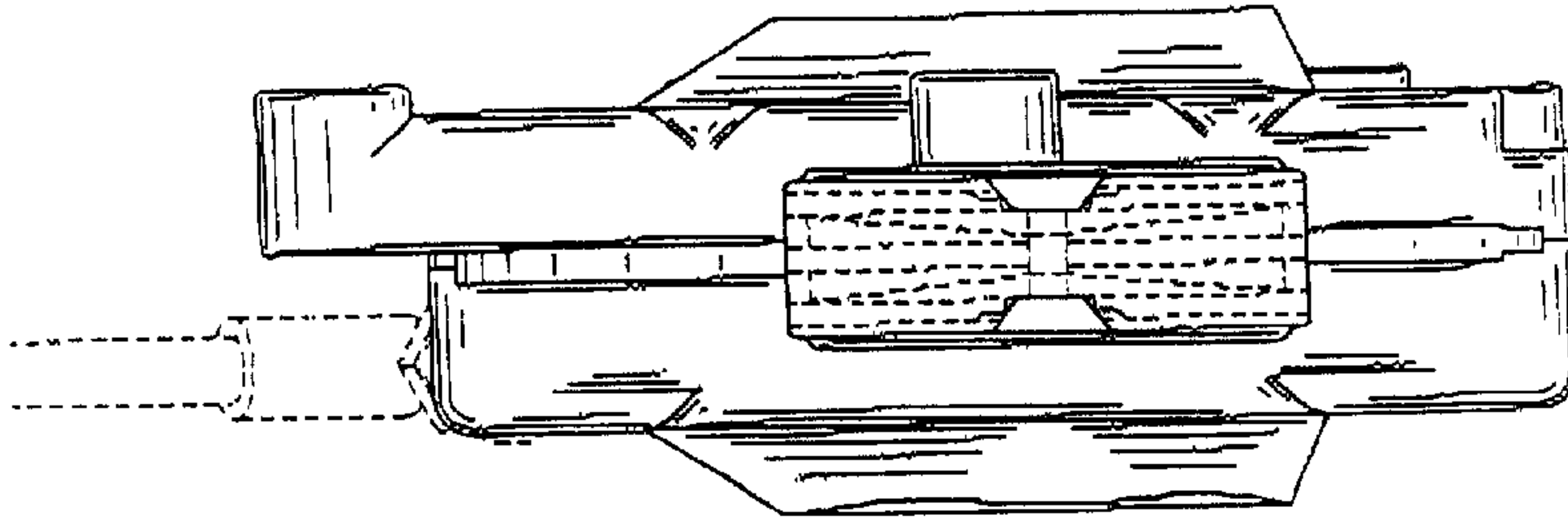

FIG. 5

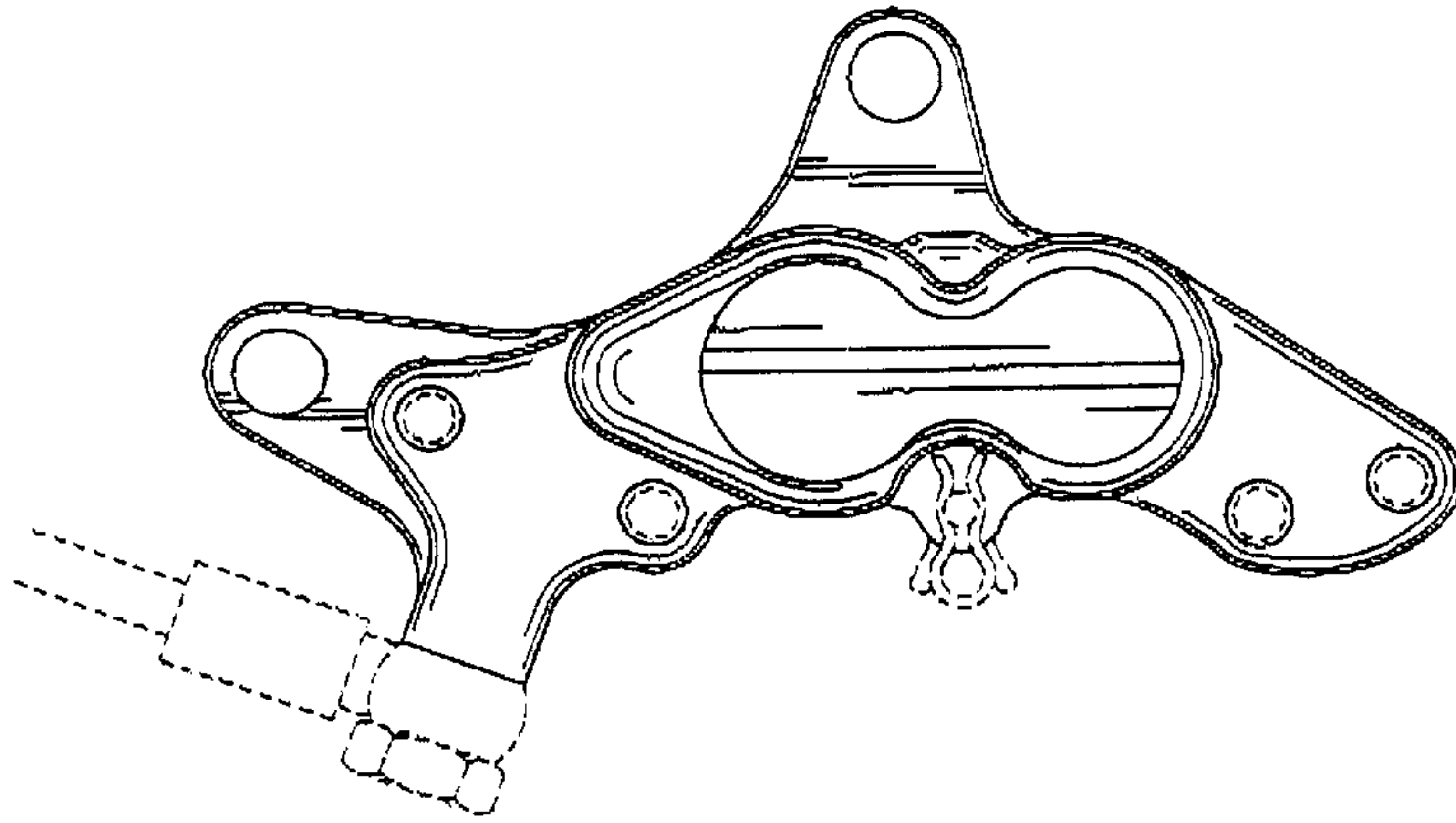

FIG. 4

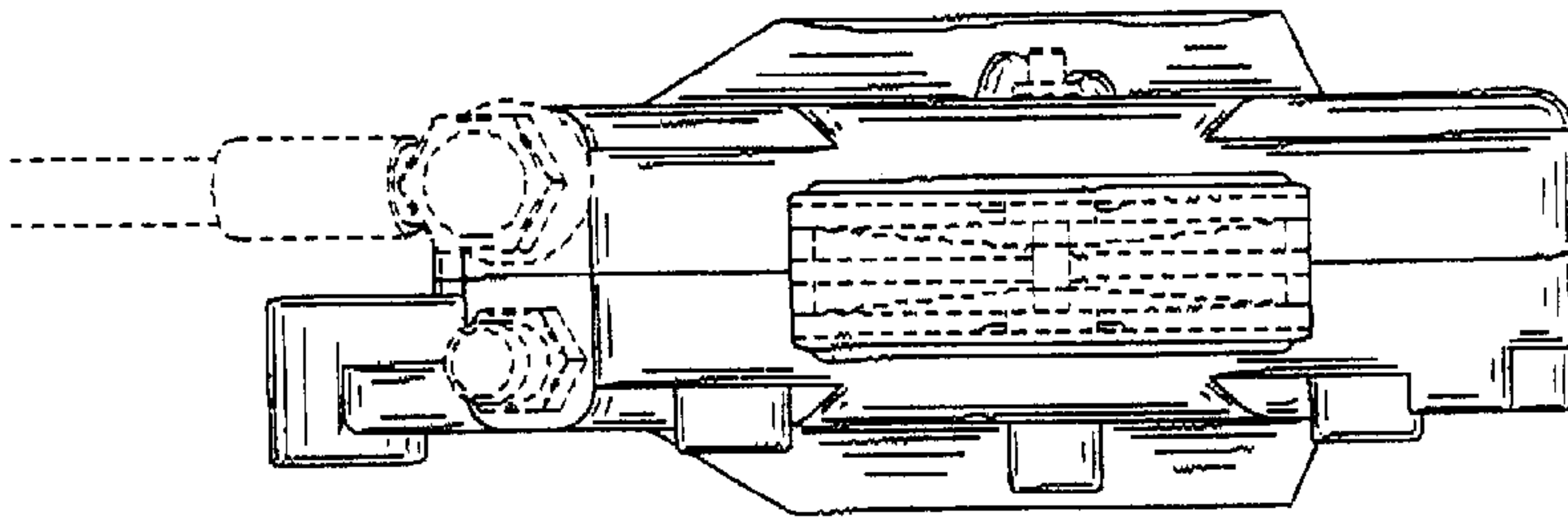

FIG. 3

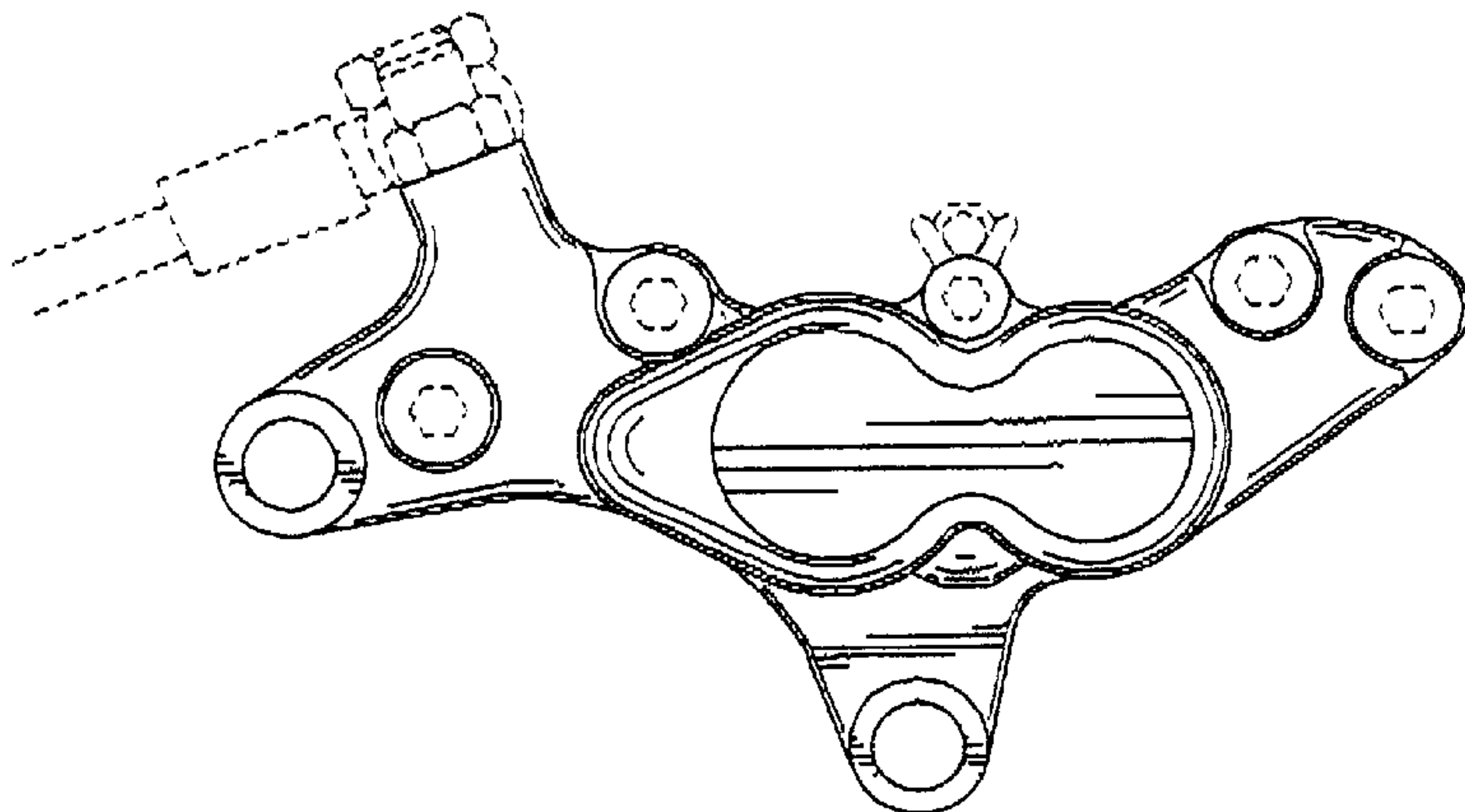

FIG. 2

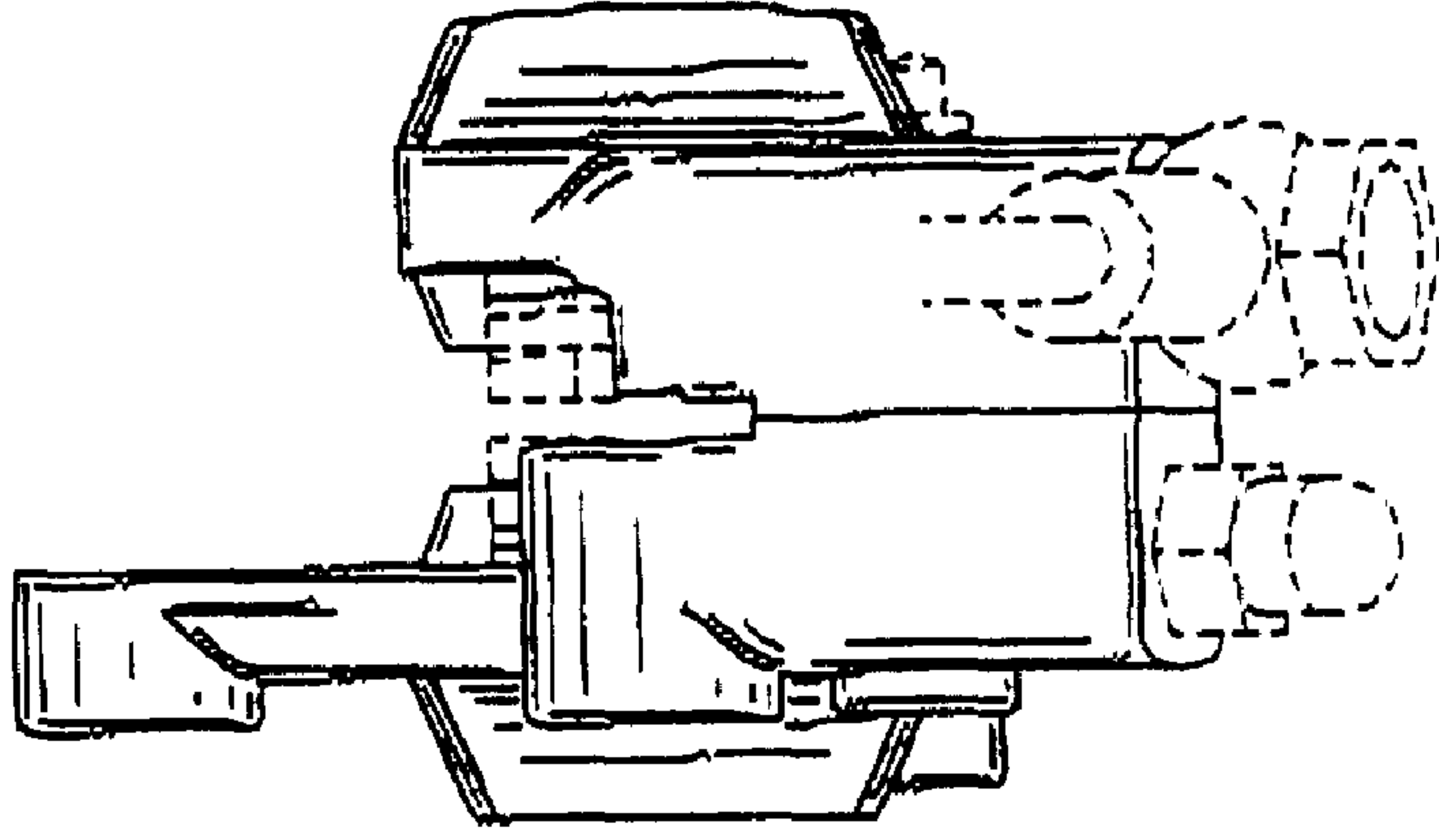

FIG. 7

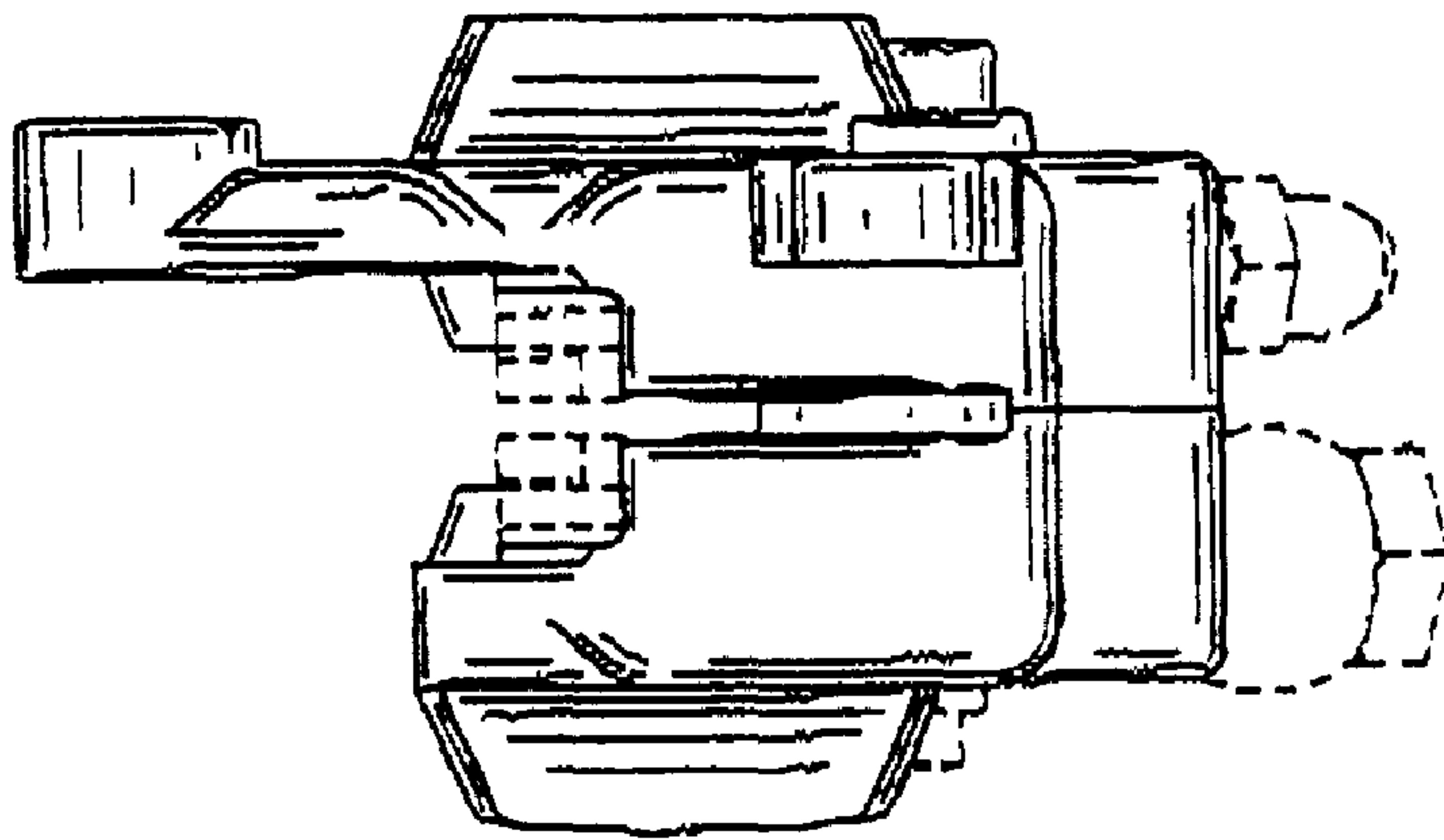

FIG. 6