



US00D437761S

(12) **United States Design Patent**  
**Okumura et al.**

(10) **Patent No.:** **US D437,761 S**

(45) **Date of Patent:** **\*\* Feb. 20, 2001**

(54) **RECHARGEABLE IMPACT WRENCH**

(75) Inventors: **Michio Okumura, Okazaki; Naohiro Hayakawa, Toyoake, both of (JP)**

(73) Assignee: **Makita Corporation, Anjo (JP)**

(\*\*) Term: **14 Years**

(21) Appl. No.: **29/123,188**

(22) Filed: **May 12, 2000**

(30) **Foreign Application Priority Data**

Nov. 19, 1999 (JP) ..... 11-32047

(51) **LOC (7) Cl.** ..... **08-05**

(52) **U.S. Cl.** ..... **D8/68**

(58) **Field of Search** ..... D8/61-70; 81/57.11,  
81/464, 466, 54, 57.42; 173/170, 93, 93.6,  
48, 93.5, 176, 169; 451/358, 359

(56) **References Cited**

**U.S. PATENT DOCUMENTS**

- D. 156,319 \* 12/1949 Bushnell ..... D8/68
- D. 159,044 \* 6/1950 Bushnell ..... D8/68
- D. 295,714 \* 5/1988 Sasaki et al. .... D8/68
- D. 320,917 \* 10/1991 Fushiya et al. .... D8/68
- D. 339,046 \* 9/1993 Fushiya et al. .... D8/68
- D. 340,394 \* 10/1993 Okumura ..... D8/68
- D. 340,396 \* 10/1993 Ichikawa ..... D8/68
- D. 342,430 \* 12/1993 Saito et al. .... D8/68
- D. 376,969 \* 12/1996 Kazamaki et al. .... D8/68
- D. 378,268 \* 3/1997 Schultz ..... D8/68
- D. 386,662 \* 11/1997 Tozawa et al. .... D8/68

- D. 392,863 3/1998 Sugimoto et al. .... D8/68
- D. 396,177 \* 7/1998 Schultz ..... D8/68
- D. 403,219 \* 12/1998 Bosten et al. .... D8/68
- D. 411,947 \* 7/1999 Sugimoto et al. .... D8/68
- D. 421,883 \* 3/2000 Watson et al. .... D8/68
- D. 424,902 \* 5/2000 Gildersleeve et al. .... D8/68
- D. 426,126 \* 6/2000 Schultz ..... D8/68
- D. 428,320 \* 7/2000 Ohi et al. .... D8/68
- 4,991,472 \* 2/1991 Hollingsworth ..... 81/464
- 5,213,913 \* 5/1993 Anthony, III et al. .... 429/97
- 5,526,460 \* 6/1996 DeFrancesco et al. .... 388/831

**FOREIGN PATENT DOCUMENTS**

929563-1 4/1995 (JP) .

\* cited by examiner

*Primary Examiner*—Jeffrey Asch

(74) *Attorney, Agent, or Firm*—Lahive & Cockfield, LLP;  
Anthony A. Laurentano

(57) **CLAIM**

The ornamental design for a rechargeable impact wrench, as shown and described.

**DESCRIPTION**

FIG. 1 is a perspective view of a rechargeable impact wrench showing our new design;  
FIG. 2 is a front view thereof;  
FIG. 3 is a rear view thereof;  
FIG. 4 is a left side elevational view thereof;  
FIG. 5 is a right side elevational view thereof;  
FIG. 6 is a top plan view thereof; and,  
FIG. 7 is a bottom plan view thereof.

**1 Claim, 7 Drawing Sheets**

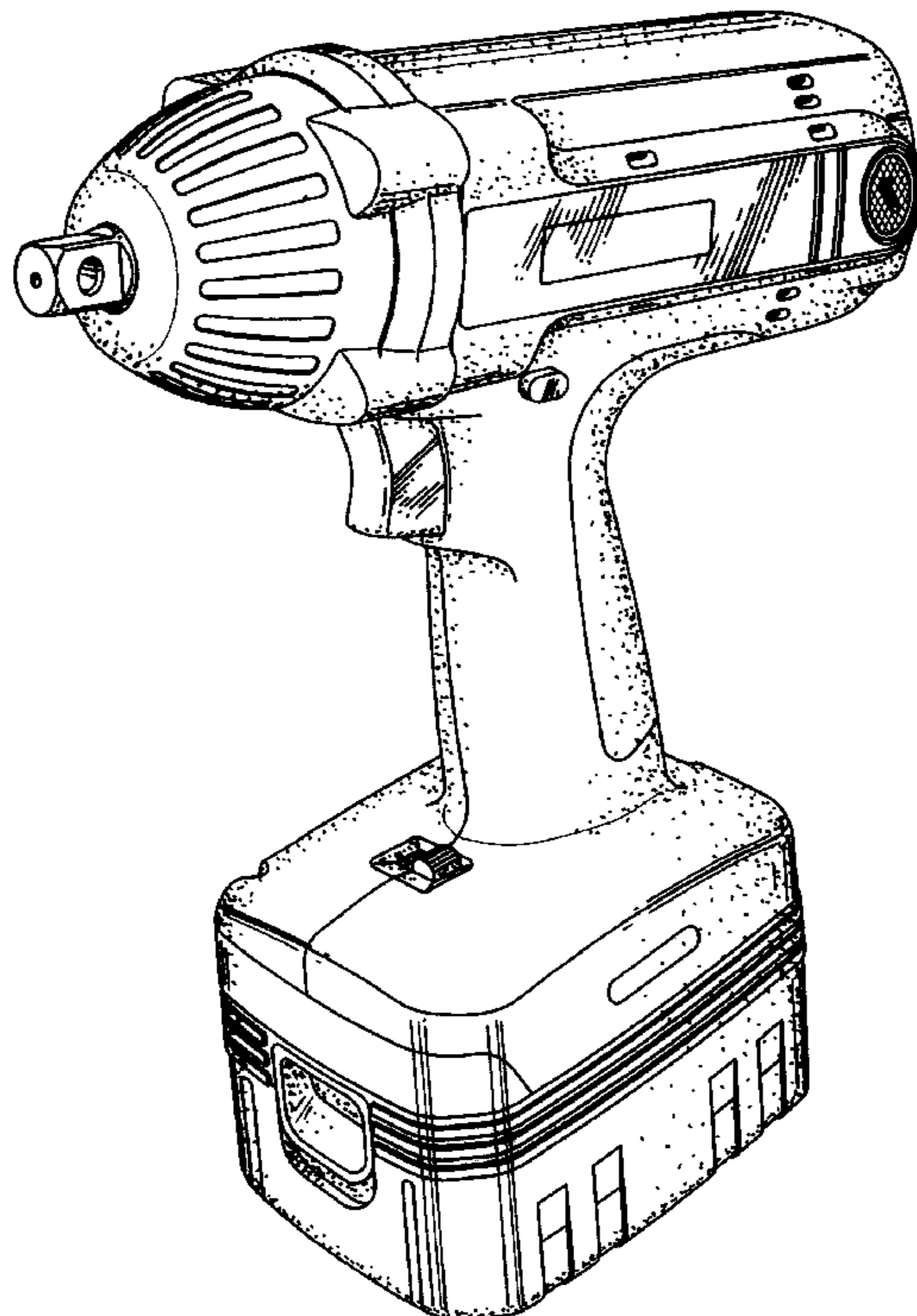

FIG. 1

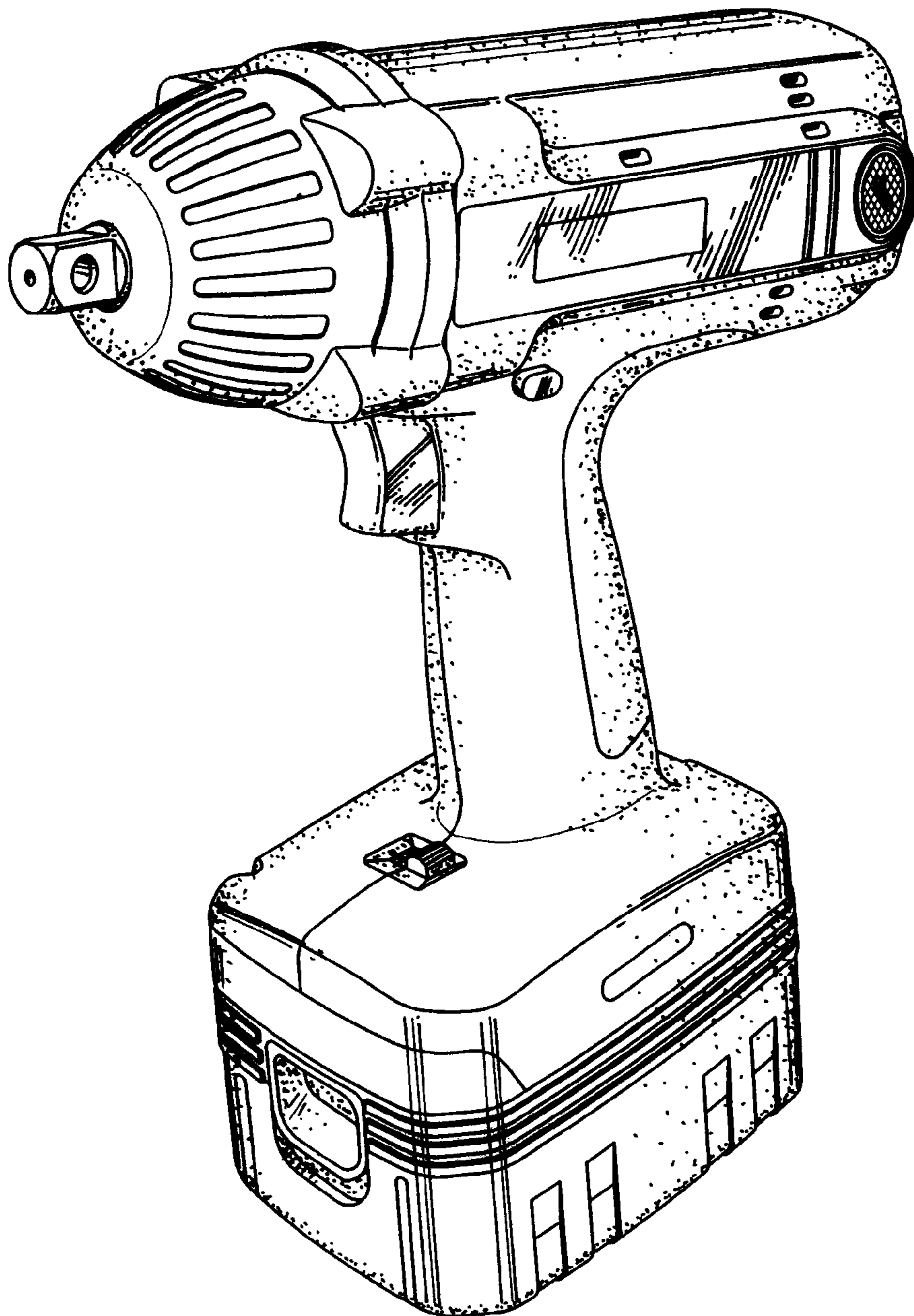

FIG. 2

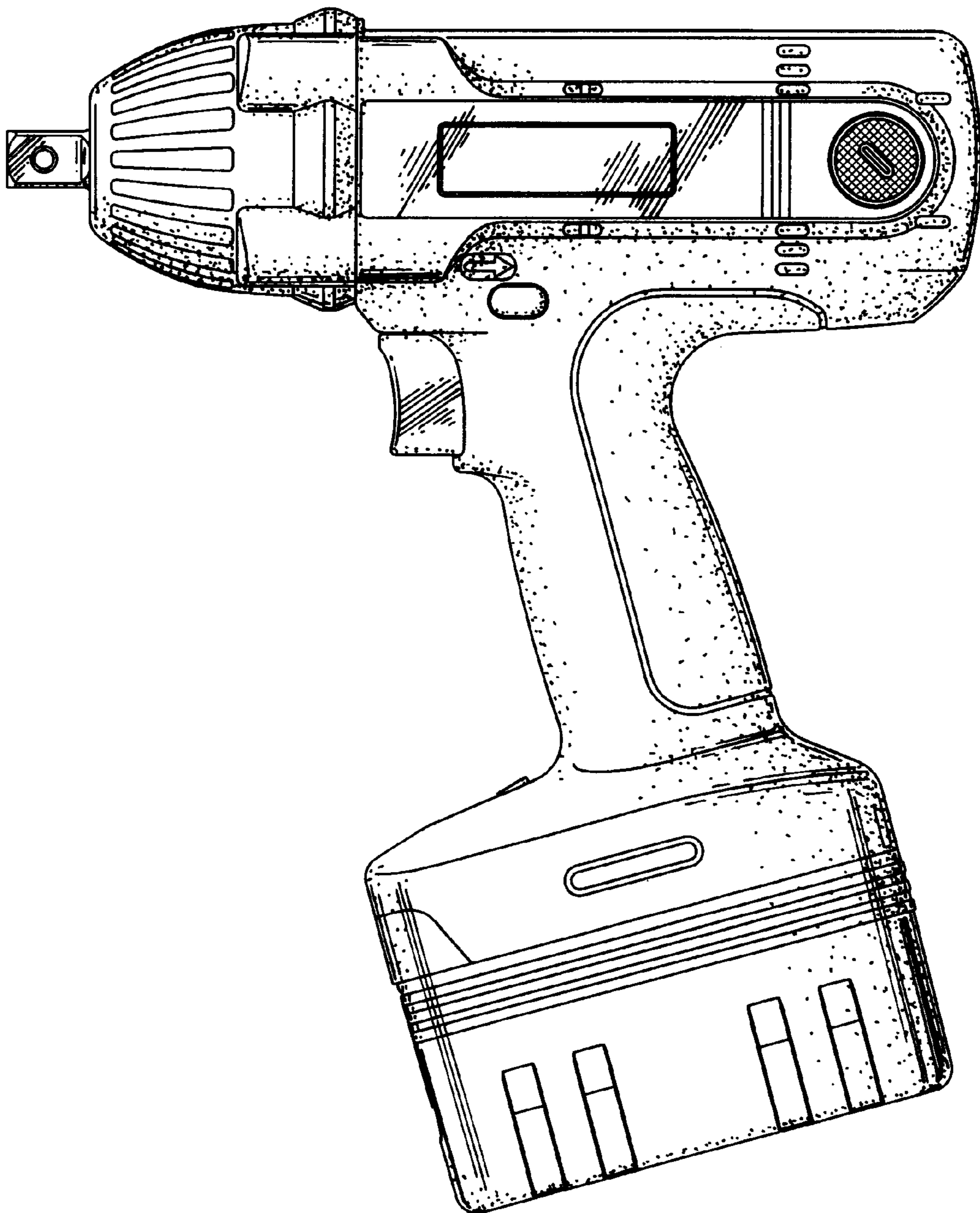



FIG. 3

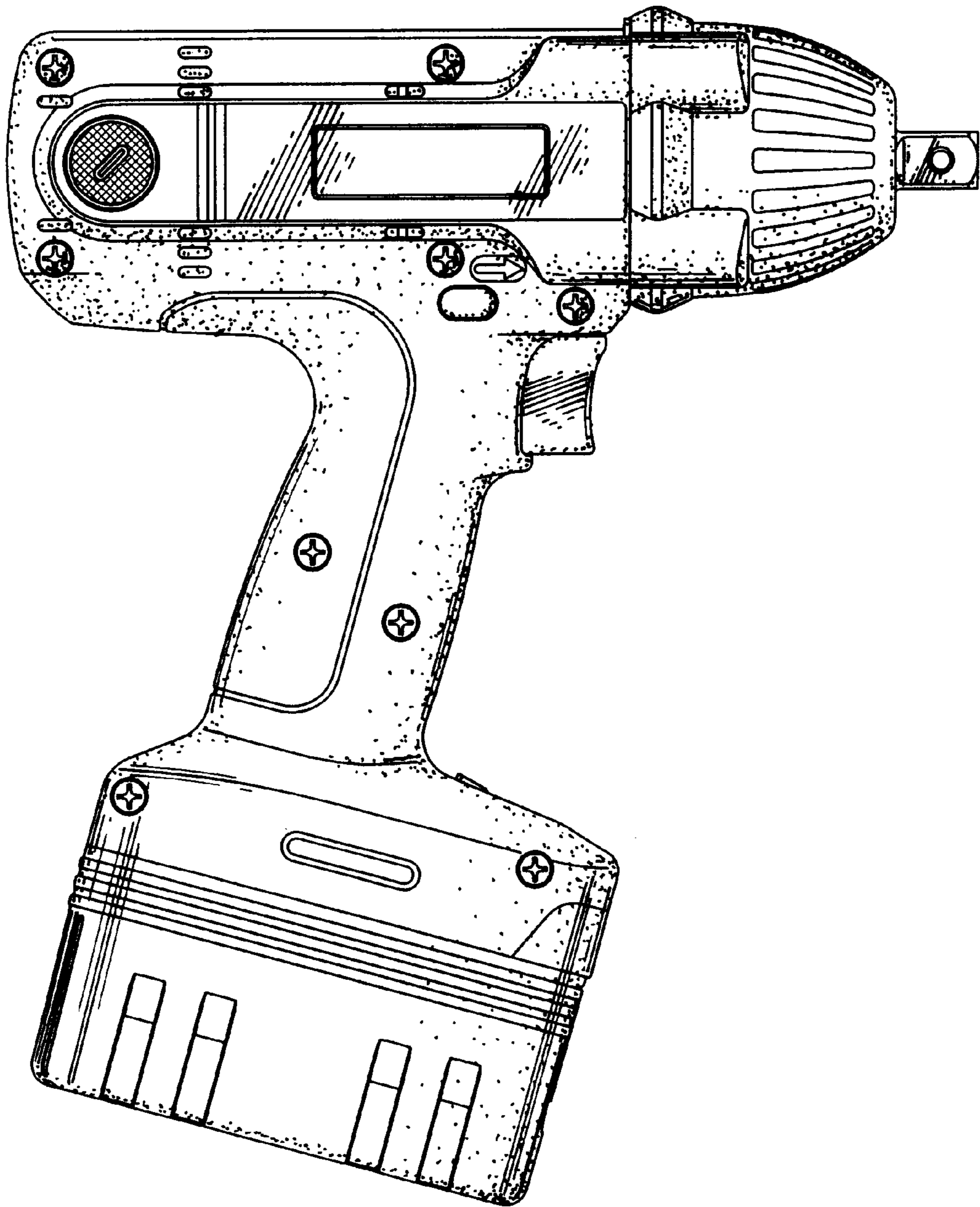

FIG. 4

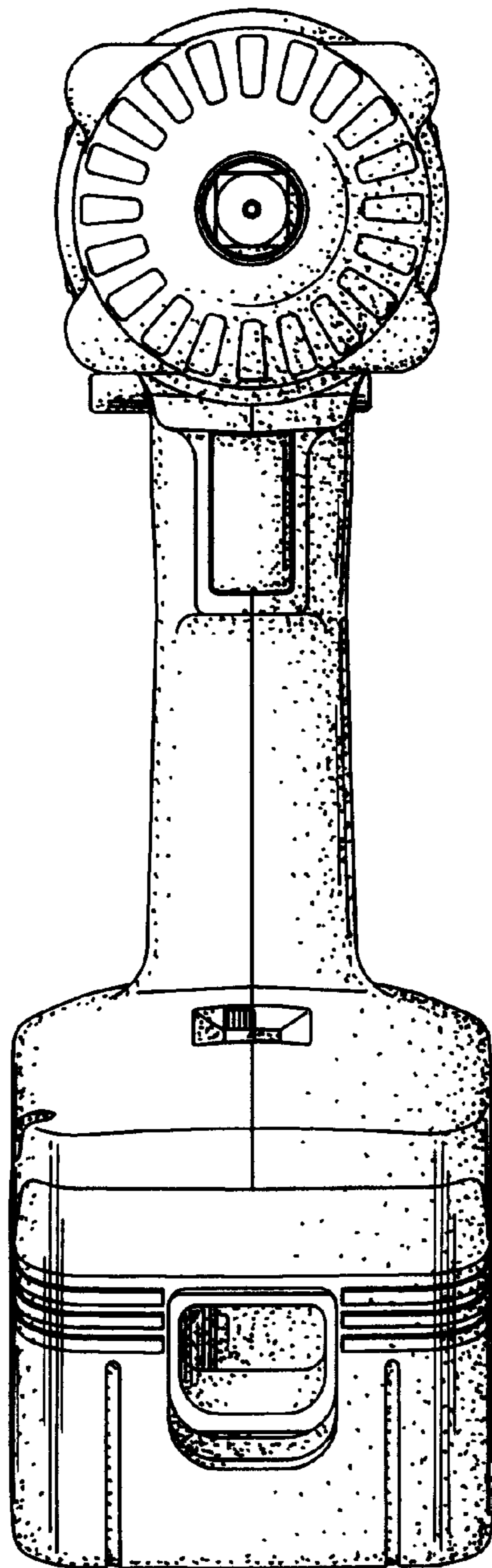

FIG. 5

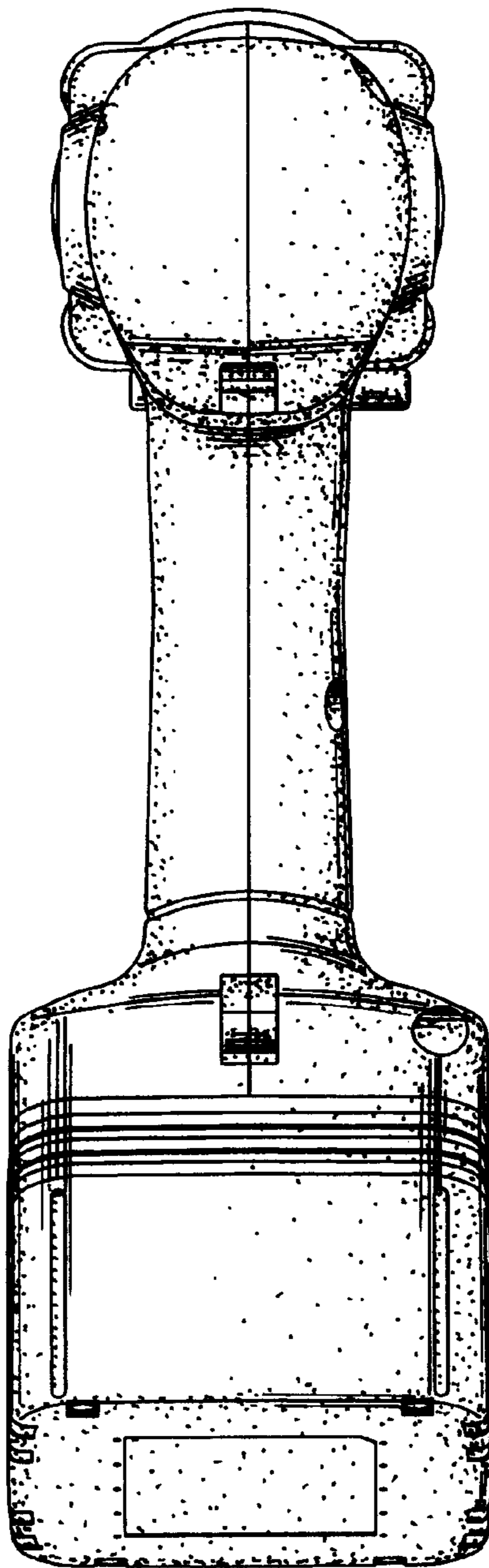

FIG. 6

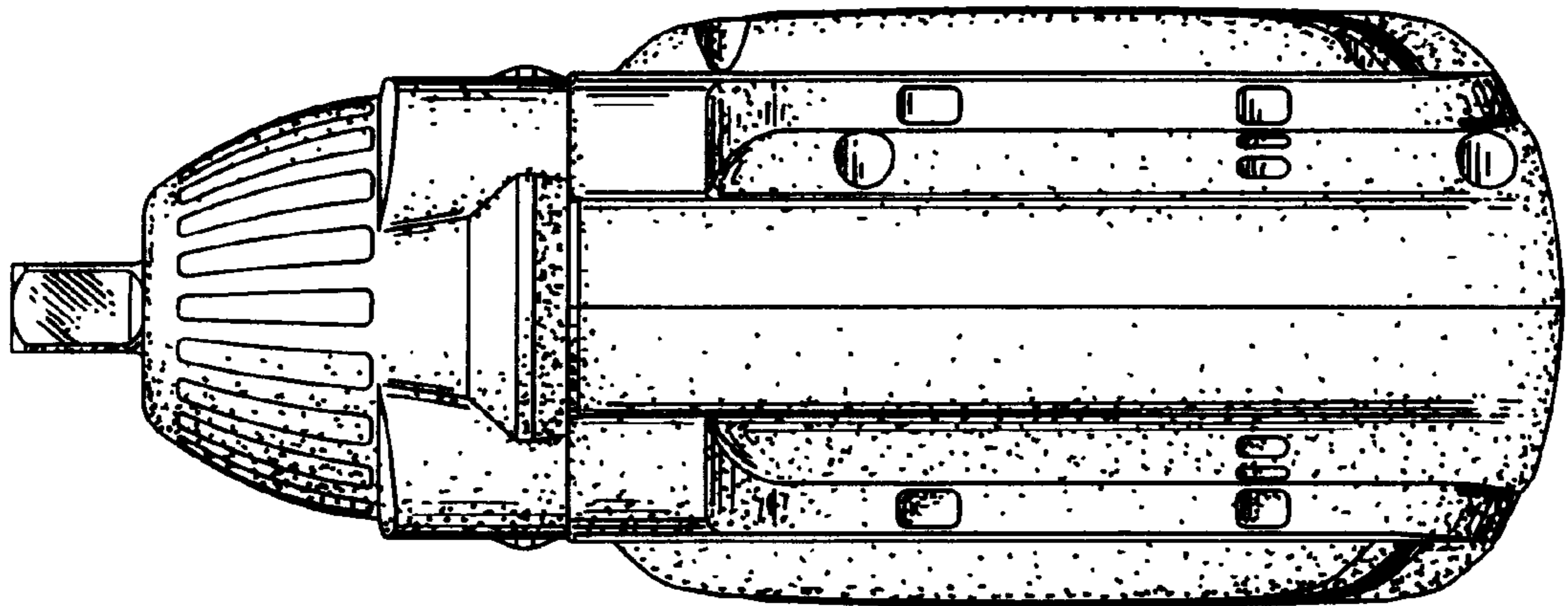

FIG. 7

