



US00D437759S

(12) **United States Design Patent**
Breit et al.

(10) **Patent No.:** **US D437,759 S**

(45) **Date of Patent:** **** Feb. 20, 2001**

(54) **CORDLESS ELECTRIC DRILL**
(75) Inventors: **Oliver Breit**, Kowloon (HK); **William Saunders**, Lithonia, GA (US)
(73) Assignee: **One World Technologies, Inc.**, Anderson, SC (US)
(**) Term: **14 Years**

D. 378,268 3/1997 Schultz .
D. 380,952 7/1997 Kim .
D. 382,457 8/1997 Ghode et al. .
D. 384,261 9/1997 Hayakawa et al. .
D. 386,662 * 11/1997 Tozawa D8/68
D. 389,384 * 1/1998 Lui D8/68
D. 392,530 * 3/1998 Lui D8/68
D. 394,995 6/1998 Cooper .
D. 396,177 * 7/1998 Schultz D8/68
5,230,261 7/1993 Akazawa et al. .

(21) Appl. No.: **29/092,247**
(22) Filed: **Aug. 14, 1998**
(51) **LOC (7) Cl.** **08-05**
(52) **U.S. Cl.** **D8/68**
(58) **Field of Search** D8/61, 64, 68,
D8/69; 81/54, 57.11, 57.13-57.14, 177.1,
177.4; 173/169-170

FOREIGN PATENT DOCUMENTS

M92 02 349 10/1992 (DE) .
M 94 01 137 8/1994 (DE) .
M94 01 141 8/1994 (DE) .
M94 06 883 1/1995 (DE) .
595750 6/1989 (JP) .
894180 3/1994 (JP) .
826221 7/1994 (JP) .

* cited by examiner

(56) **References Cited**
U.S. PATENT DOCUMENTS

D. 279,957 8/1985 Akazawa et al. .
D. 295,141 4/1988 Hoshino et al. .
D. 296,413 6/1988 Hoshino et al. .
D. 296,655 7/1988 Yonezawa et al. .
D. 299,808 2/1989 Hoshino et al. .
D. 314,498 2/1991 Hoshino et al. .
D. 323,606 2/1992 Chang .
D. 327,619 7/1992 Tsai .
D. 329,580 9/1992 Sasaki et al. .
D. 332,208 1/1993 Sakamoto et al. .
D. 335,073 4/1993 Anthony et al. .
D. 339,727 9/1993 Kikuchi .
D. 340,394 10/1993 Okumura .
D. 345,090 3/1994 Okumura .
D. 359,215 6/1995 Zurwelle .
D. 360,814 8/1995 Kimata .
D. 362,167 * 9/1995 Zurwelle D8/68
D. 368,214 3/1996 Zurwelle .
D. 377,442 * 1/1997 Kikuchi D8/68
D. 377,893 * 2/1997 Lui D8/68

Primary Examiner—Nelson C. Holtje
(74) *Attorney, Agent, or Firm*—Brooks & Kushman P.C.

(57) **CLAIM**

The ornamental design for a cordless electric drill, as shown and described.

DESCRIPTION

FIG. 1 is a right side elevational view of a cordless electric drill;
FIG. 2 is a left side elevational view;
FIG. 3 is a top plan view;
FIG. 4 is a bottom plan view;
FIG. 5 is a front end elevational view; and,
FIG. 6 is a rear end elevational view.
The broken-line showings in all figures are for illustrative purposes only and form no part of the claimed design.

1 Claim, 2 Drawing Sheets

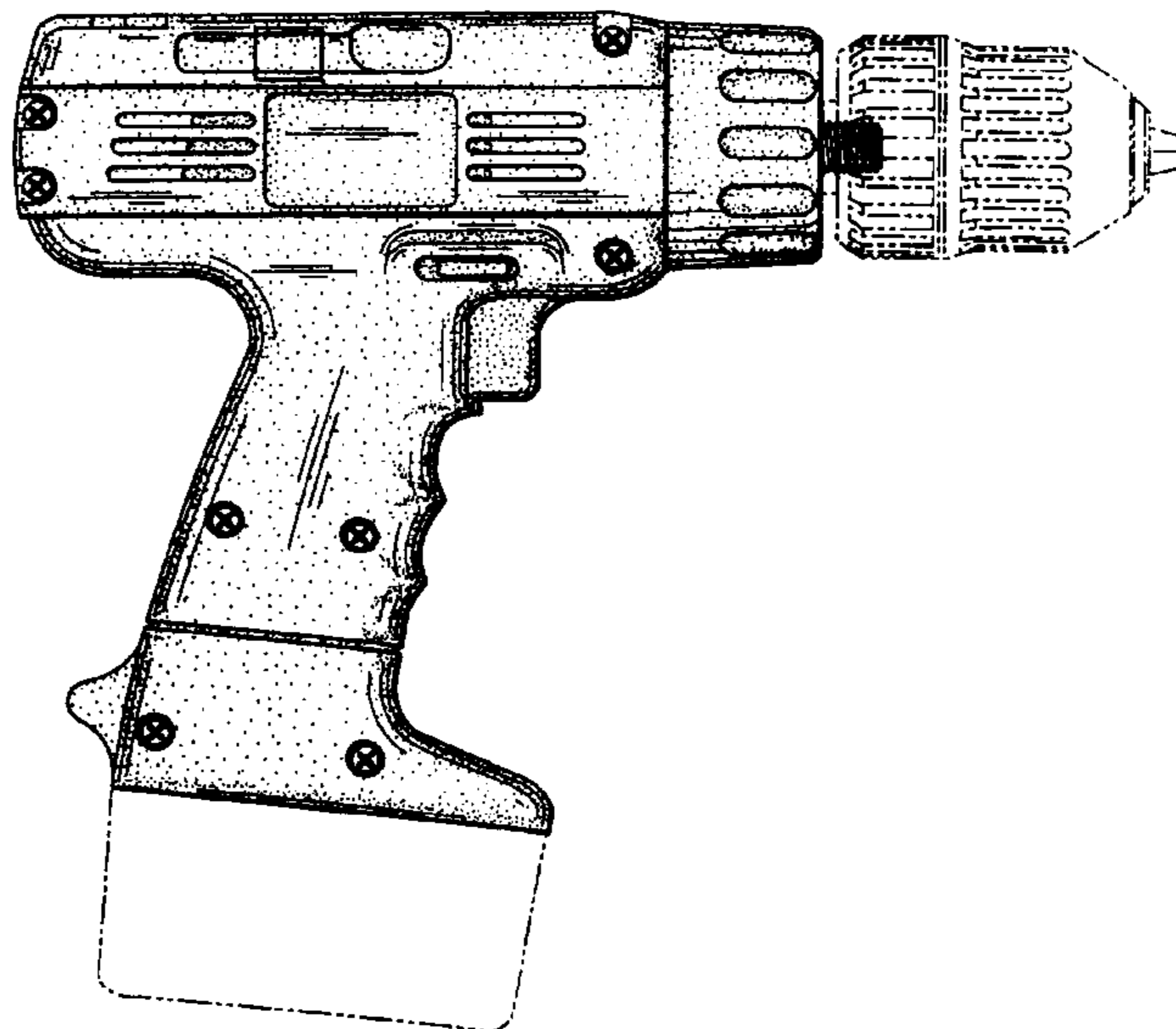

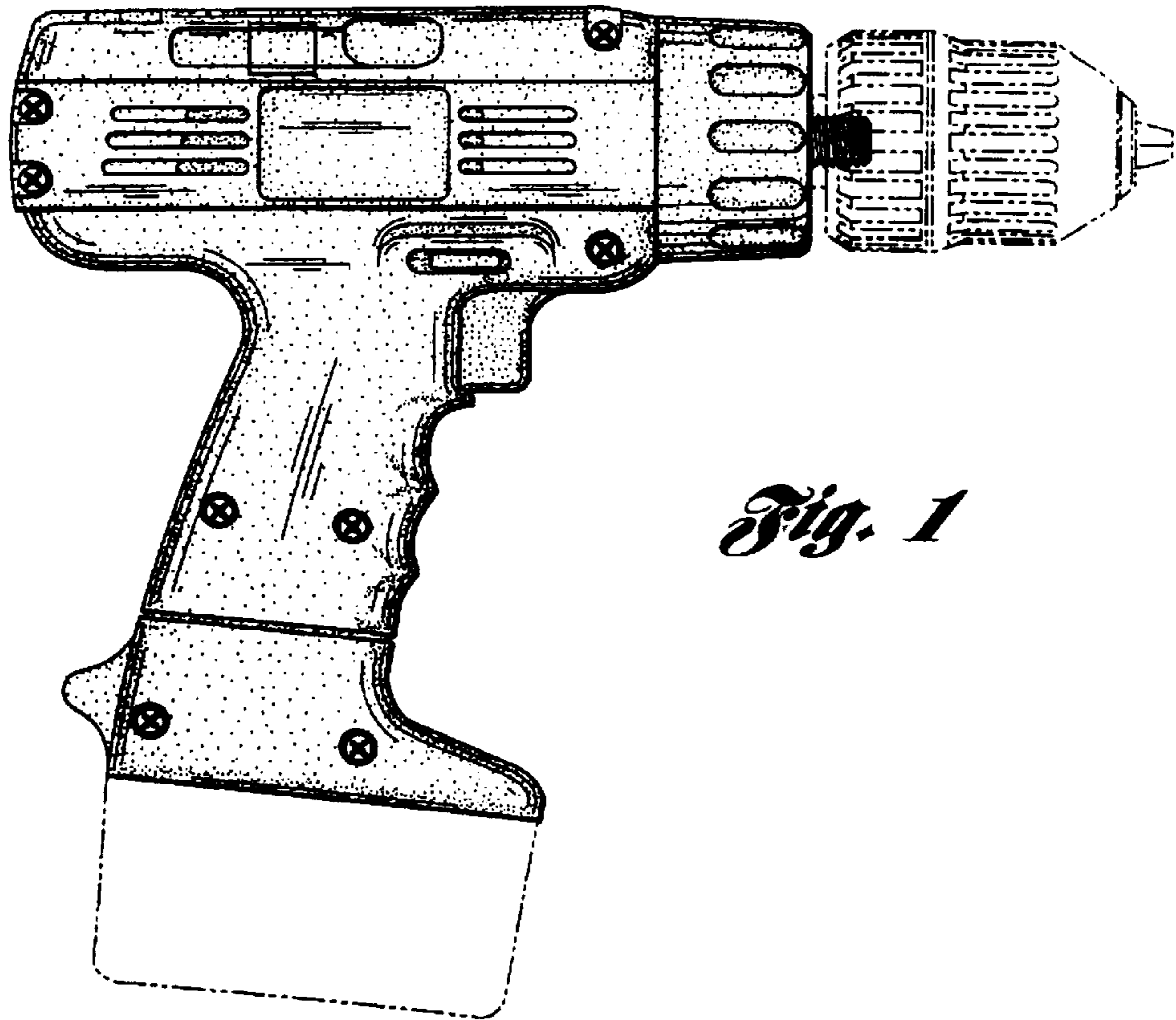

Fig. 1

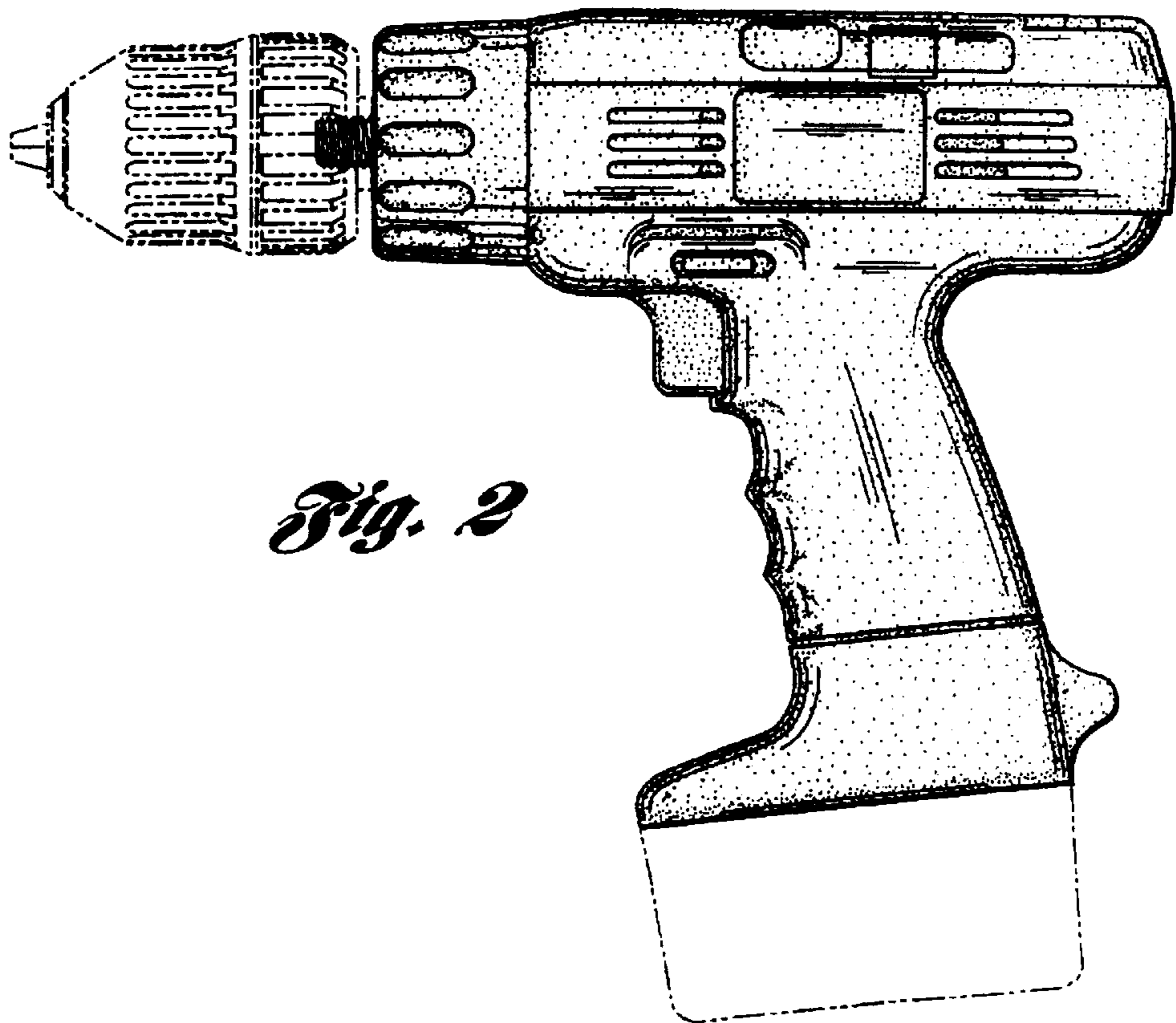

Fig. 2

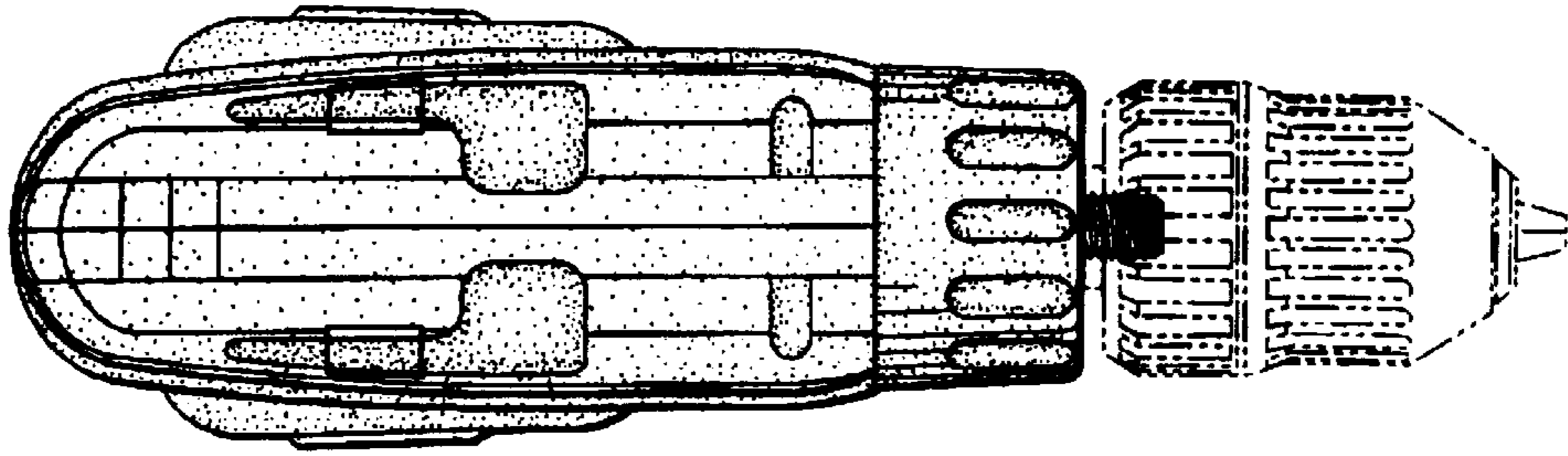

Fig. 3

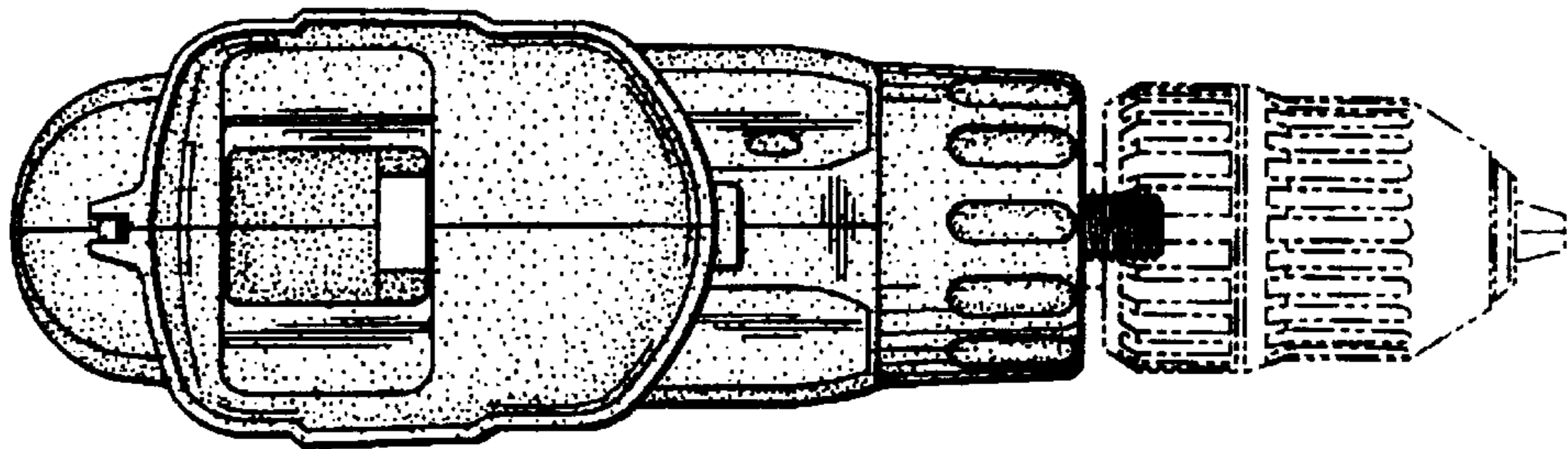

Fig. 4

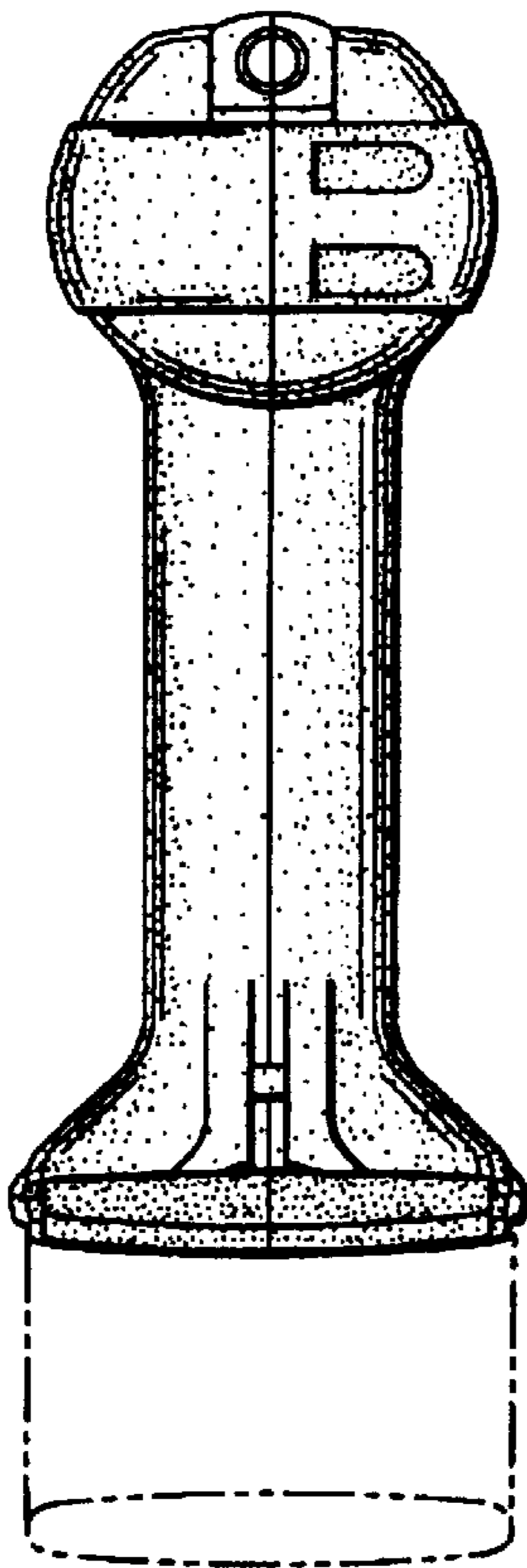

Fig. 5

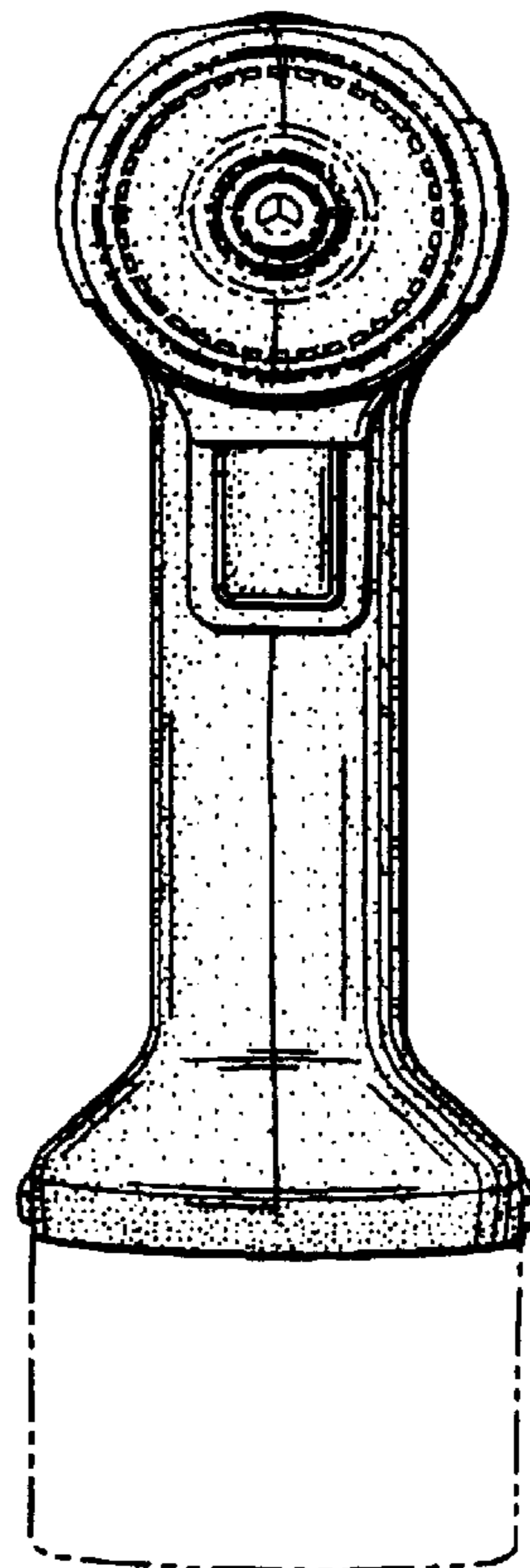

Fig. 6