



US00D437571S

(12) **United States Design Patent**
Mason et al.

(10) **Patent No.:** **US D437,571 S**

(45) **Date of Patent:** **** Feb. 13, 2001**

(54) **BILLET ALUMINUM TRIPLE TREES FOR MOTORCYCLE FORKS**

Drage Specialties, triple tree numbers DS-22903, DS-22904, and DS-22906, on p. 471, 1995.*

(76) Inventors: **Charles C. Mason**, 101 Staring Dr., Gastonia, NC (US) 28052; **Duane A. Branham**, 1313 N. Main St., Apt. 3, Lowell, NC (US) 28098; **Terry W. Ballard**, P.O. Box 424, Iron Station, NC (US) 28080

* cited by examiner

Primary Examiner—Alan P. Douglas

Assistant Examiner—Linda Brooks

(74) *Attorney, Agent, or Firm*—Dougherty & Associates

(**) **Term:** **14 Years**

(57) **CLAIM**

The ornamental design for billet aluminum triple trees for motorcycle forks, as shown and described.

(21) **Appl. No.:** **29/098,747**

DESCRIPTION

(22) **Filed:** **Jan. 5, 1999**

(51) **LOC (7) Cl.** **12-11**

(52) **U.S. Cl.** **D12/118**

(58) **Field of Search** D12/118, 223;
280/278-280, 281.1

FIG. 1 is a perspective view of the billet aluminum triple trees for motorcycle forks showing the new design with an inserted illuminated panel;

FIG. 2 is a top view of the billet aluminum triple trees for motorcycle forks on a reduced scale;

FIG. 3 is a left side view of FIG. 2;

FIG. 4 is a back view of FIG. 2;

FIG. 5 is a front view of FIG. 2;

FIG. 6 is a right side view of FIG. 2; and,

FIG. 7 is a bottom view of FIG. 2.

The broken line showing of environmental features and a name tag is for illustrative purposes only and forms no part of the claimed design.

(56) **References Cited**

U.S. PATENT DOCUMENTS

D. 74,932 * 4/1928 Lake, Jr. D12/118
5,967,538 * 10/1999 Callaluca et al. 280/279

OTHER PUBLICATIONS

Sullivans Catalog, triple tree shown assembled at top of p. 85, 1998.*

Drag Specialties, triple trees in section E, p. 123, 1987.*

1 Claim, 2 Drawing Sheets

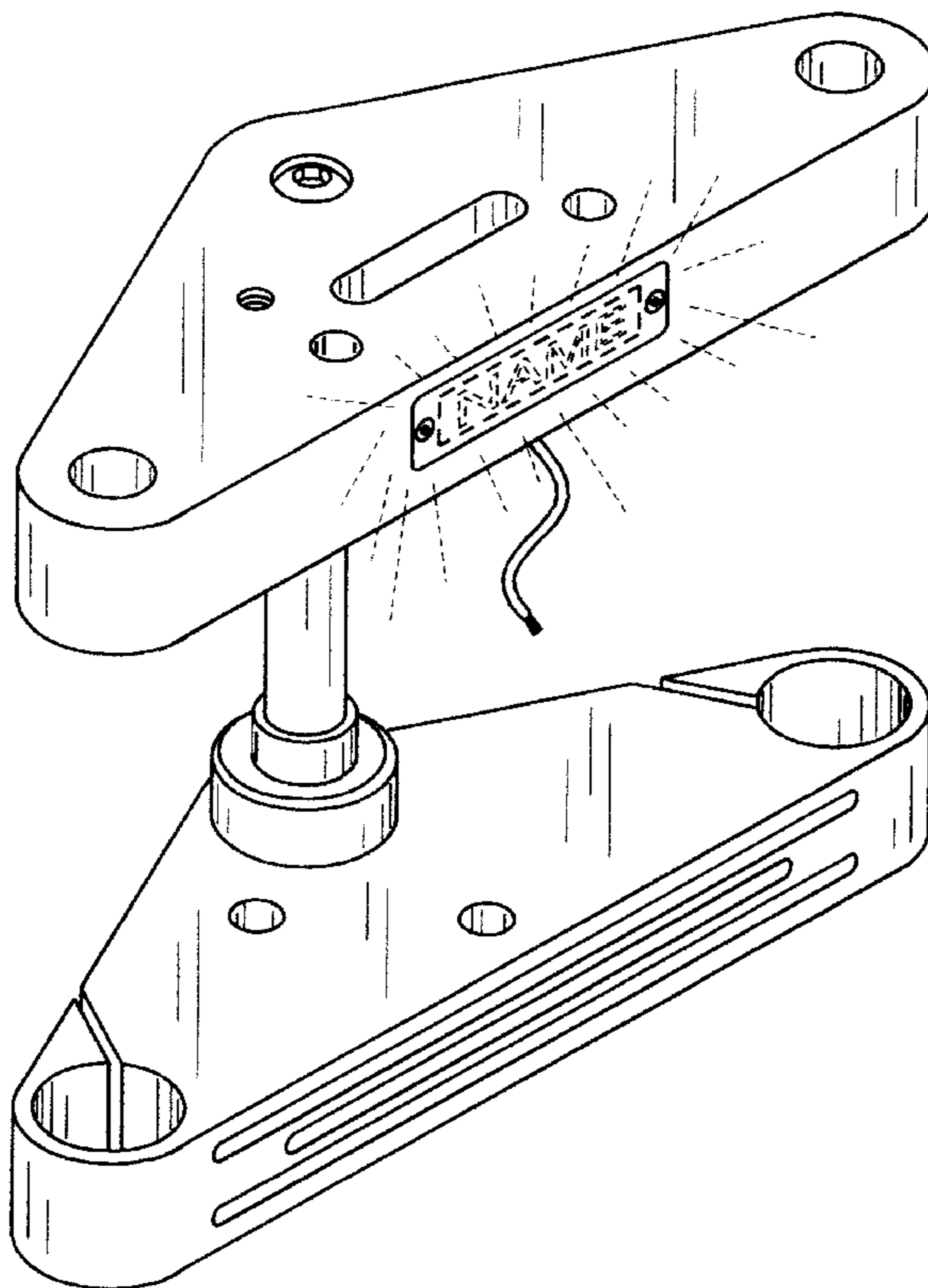

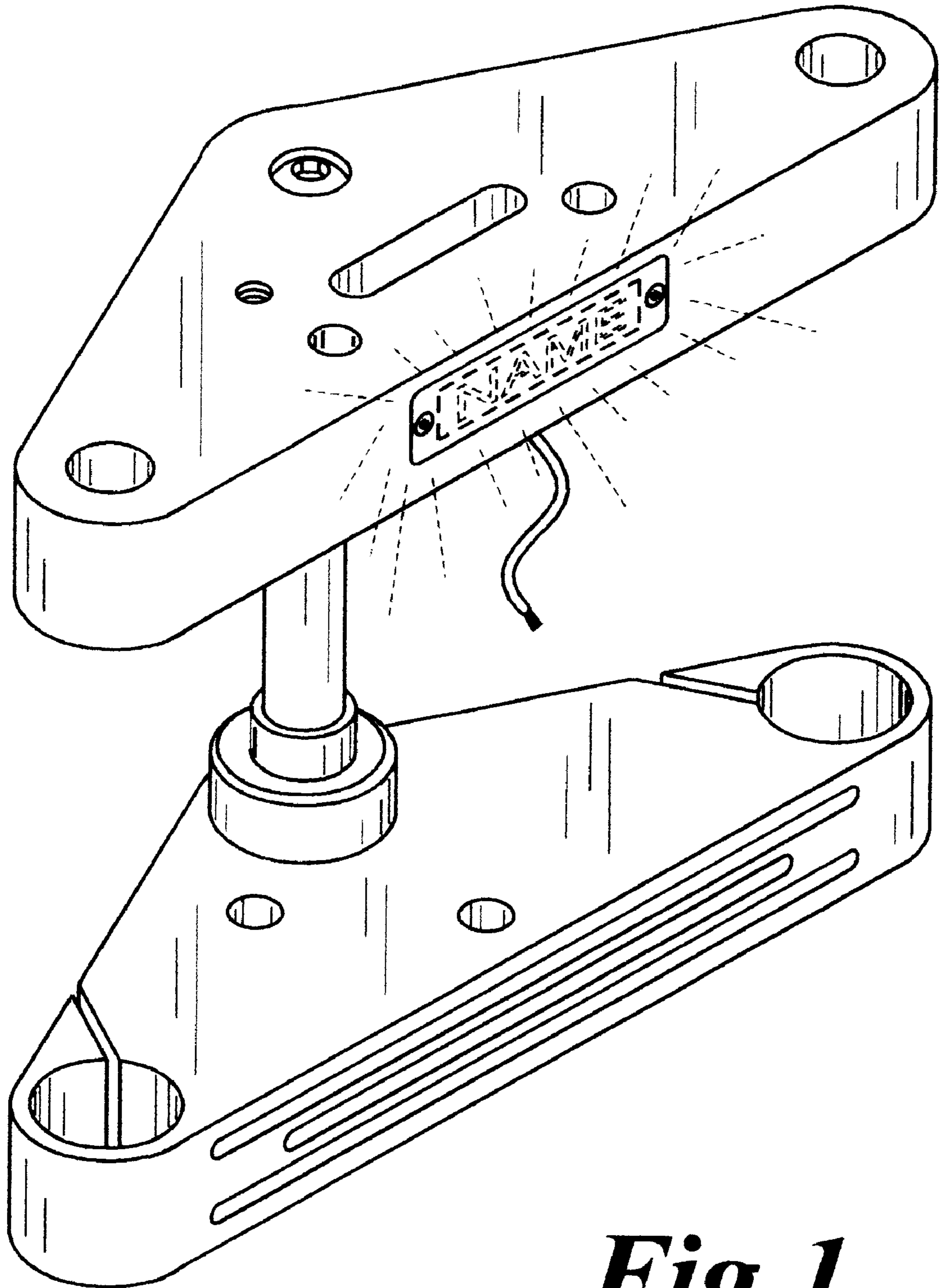

Fig. 1

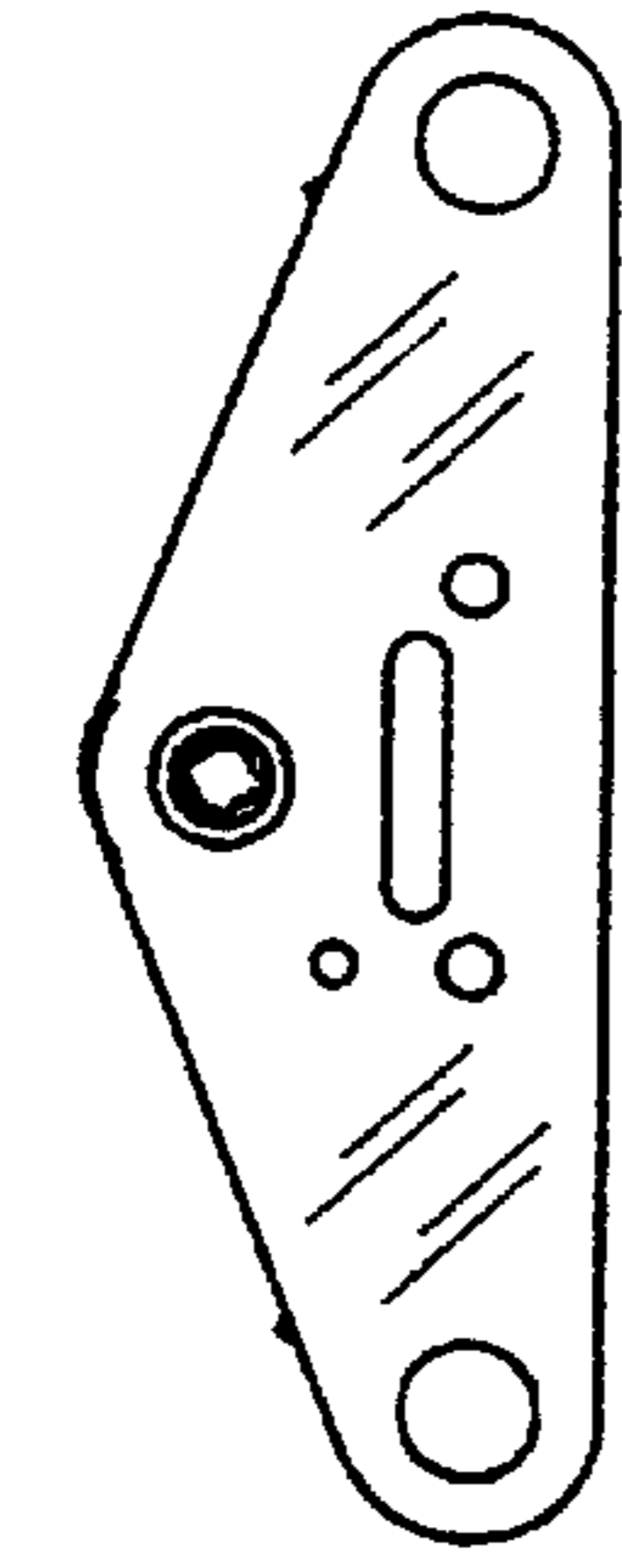

Fig. 2



Fig. 3

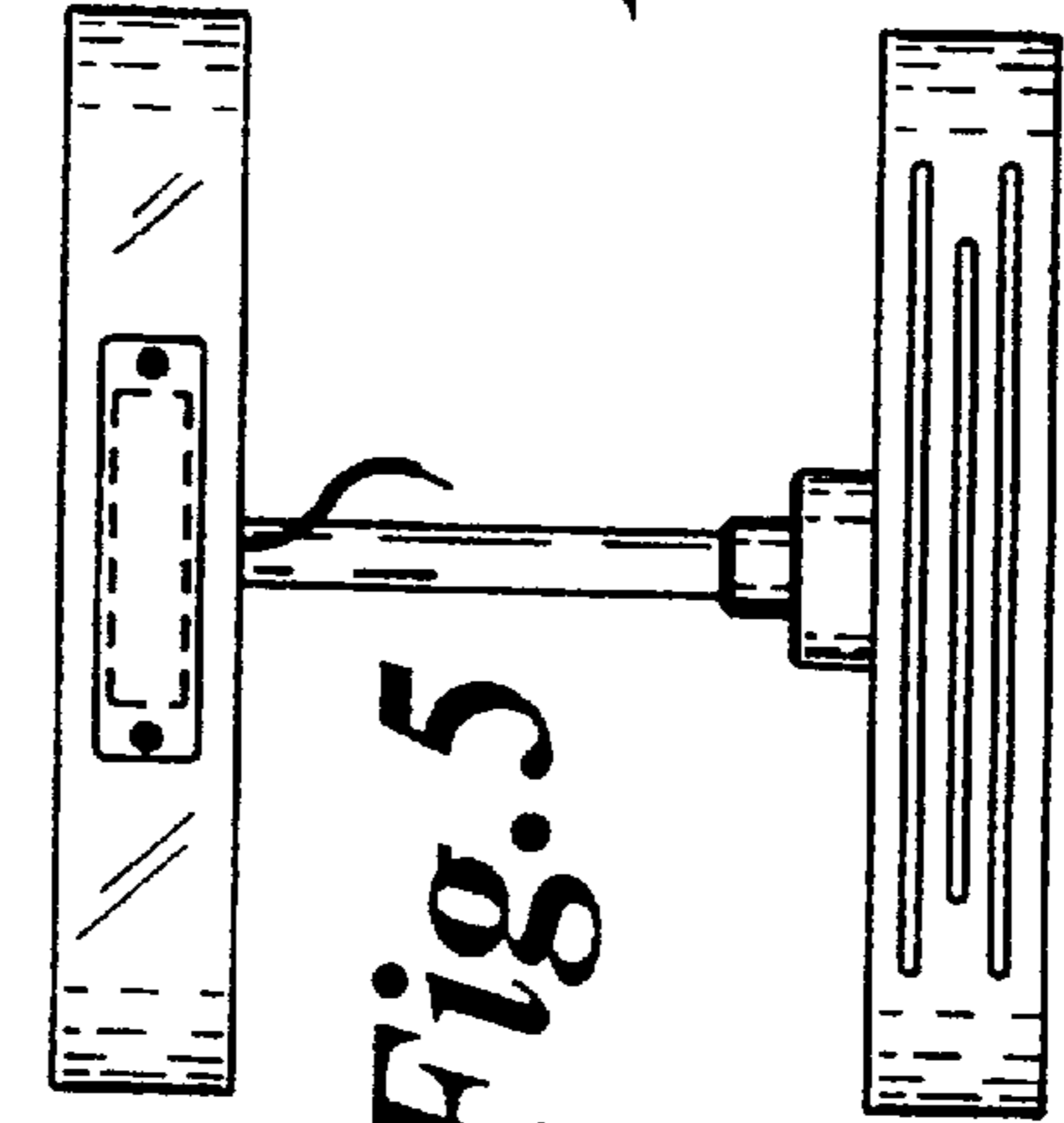

Fig. 4



Fig. 5



Fig. 6

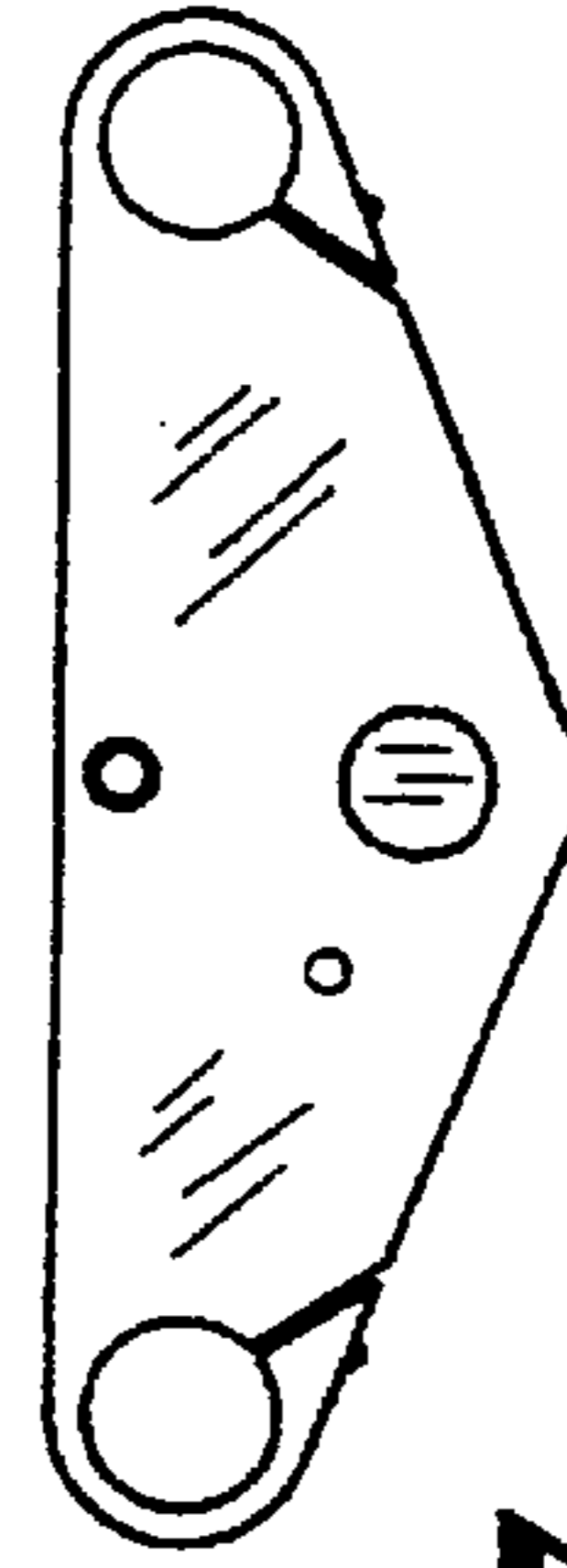

Fig. 7