



US00D437257S

(12) **United States Design Patent**
Hsu et al.

(10) **Patent No.:** **US D437,257 S**

(45) **Date of Patent:** **** Feb. 6, 2001**

(54) **AUTOMOBILE**

(75) Inventors: **Ricky Ju Kuei Hsu**, Gardena; **Michael Patrick May**, Redondo Beach, both of CA (US)

(73) Assignee: **Honda Giken Kogyo Kabushiki Kaisha (JP)**

(**) Term: **14 Years**

(21) Appl. No.: **29/119,748**

(22) Filed: **Mar. 8, 2000**

Related U.S. Application Data

(62) Division of application No. 29/090,578, filed on Jul. 10, 1998, now Pat. No. Des. 425,824.

(51) **LOC (7) Cl.** **12-08**

(52) **U.S. Cl.** **D12/92**

(58) **Field of Search** D12/90-92; 296/185

(56) **References Cited**

U.S. PATENT DOCUMENTS

- D. 351,573 10/1994 Kong et al. .
- D. 372,687 8/1996 Boyer .
- D. 373,334 9/1996 Honda et al. .

- D. 379,946 6/1997 Tanabe et al. .
- D. 379,947 6/1997 Ichinore et al. .
- D. 391,523 3/1998 Sacco et al. .
- D. 402,232 12/1998 Hayauchi et al. .
- D. 425,824 * 5/2000 Hsu et al. D12/92

* cited by examiner

Primary Examiner—Melody N. Brown

(74) *Attorney, Agent, or Firm*—Birch, Stewart, Kolasch & Birch, LLP

(57) **CLAIM**

We claim the ornamental design of an automobile, as shown and described.

DESCRIPTION

FIG. 1 is a top plan view of an automobile showing our new design;

FIG. 2 is a right side elevational view thereof, the left side being a mirror image of that shown;

FIG. 3 is a rear elevational view thereof;

FIG. 4 is a front elevational view thereof;

FIG. 5 is a right, front perspective view thereof; and,

FIG. 6 is a left, rear perspective view thereof.

The broken line showings are for environmental purposes only and form no part of the claimed design.

1 Claim, 5 Drawing Sheets

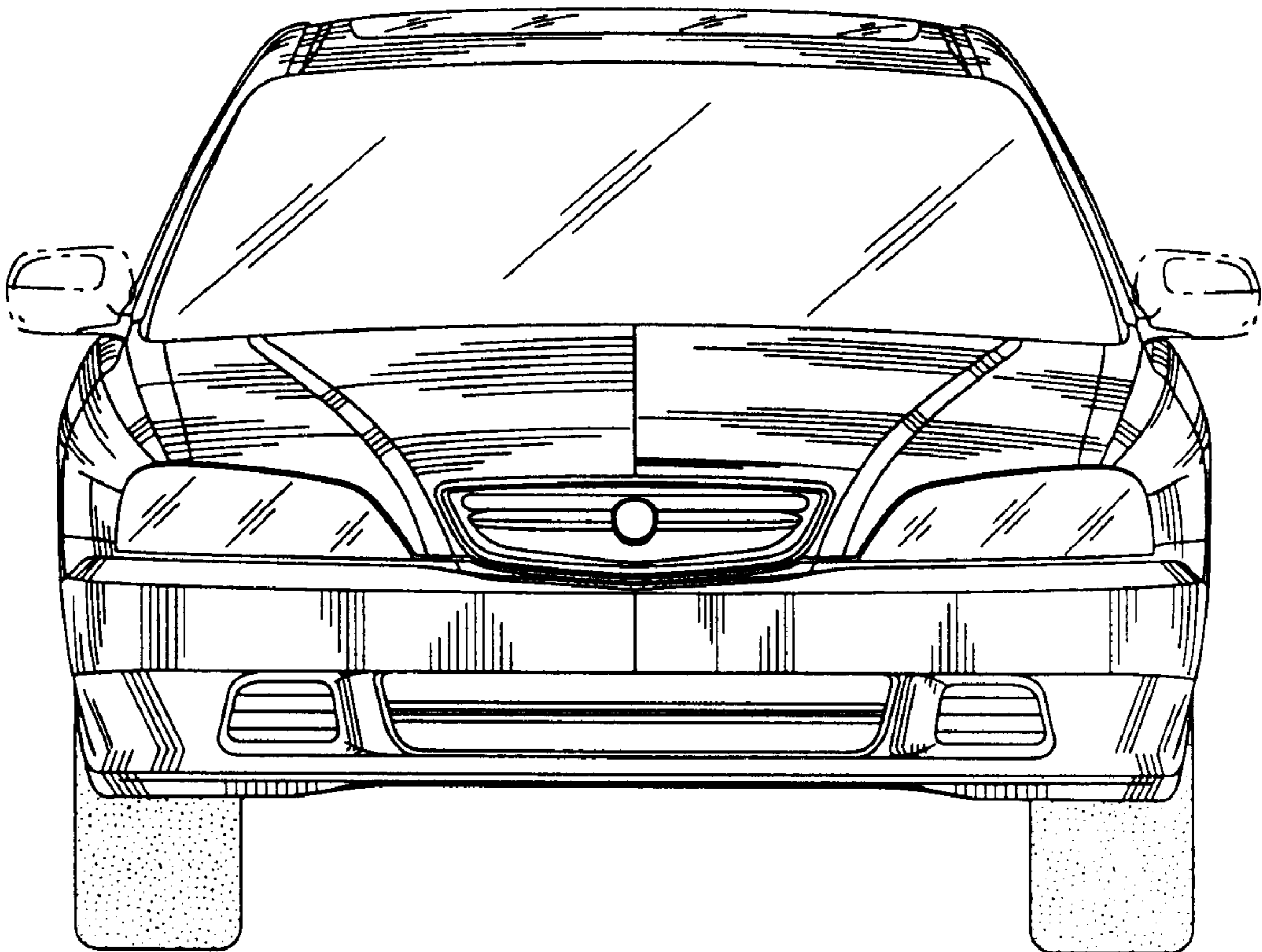

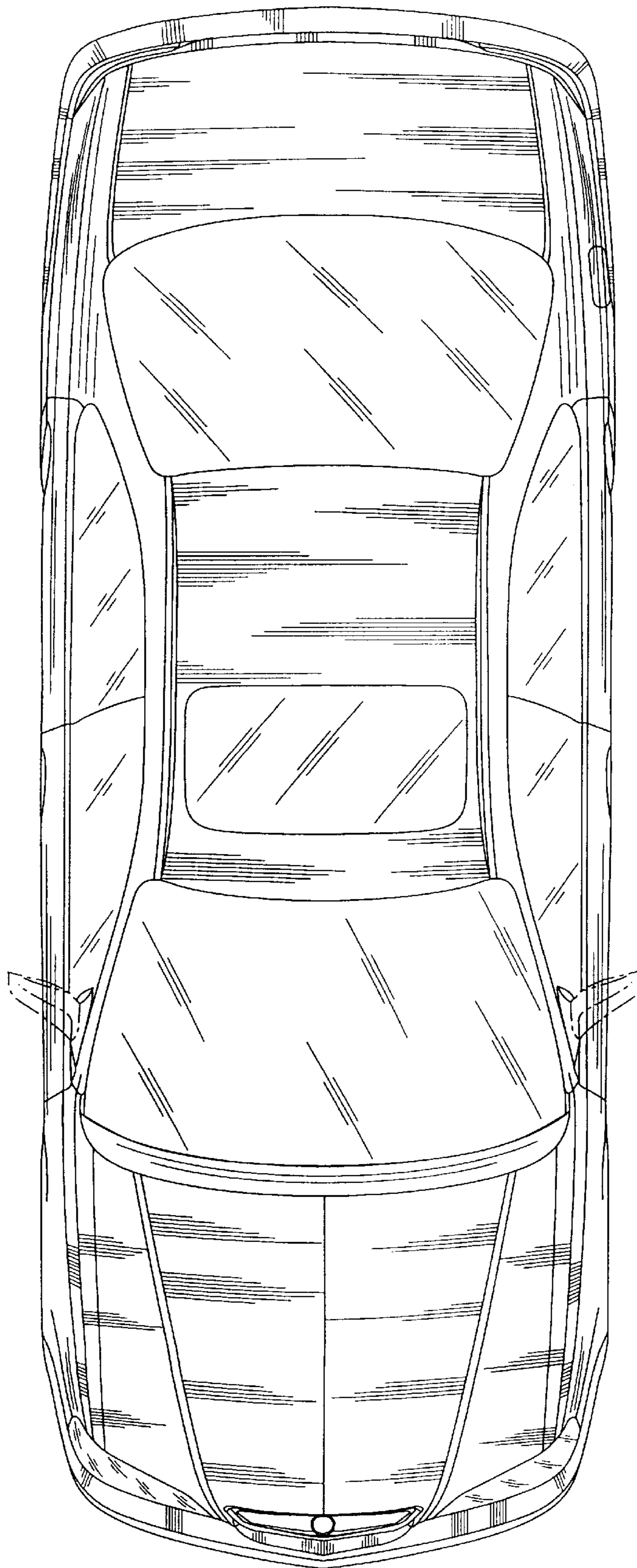

FIG. 1

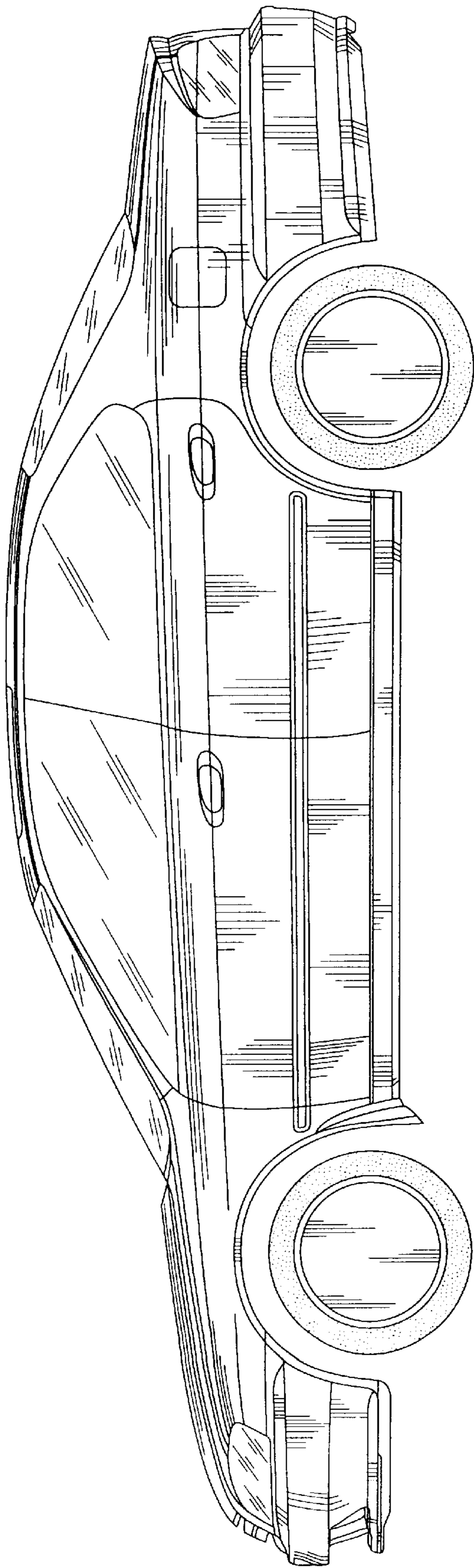

FIG. 2

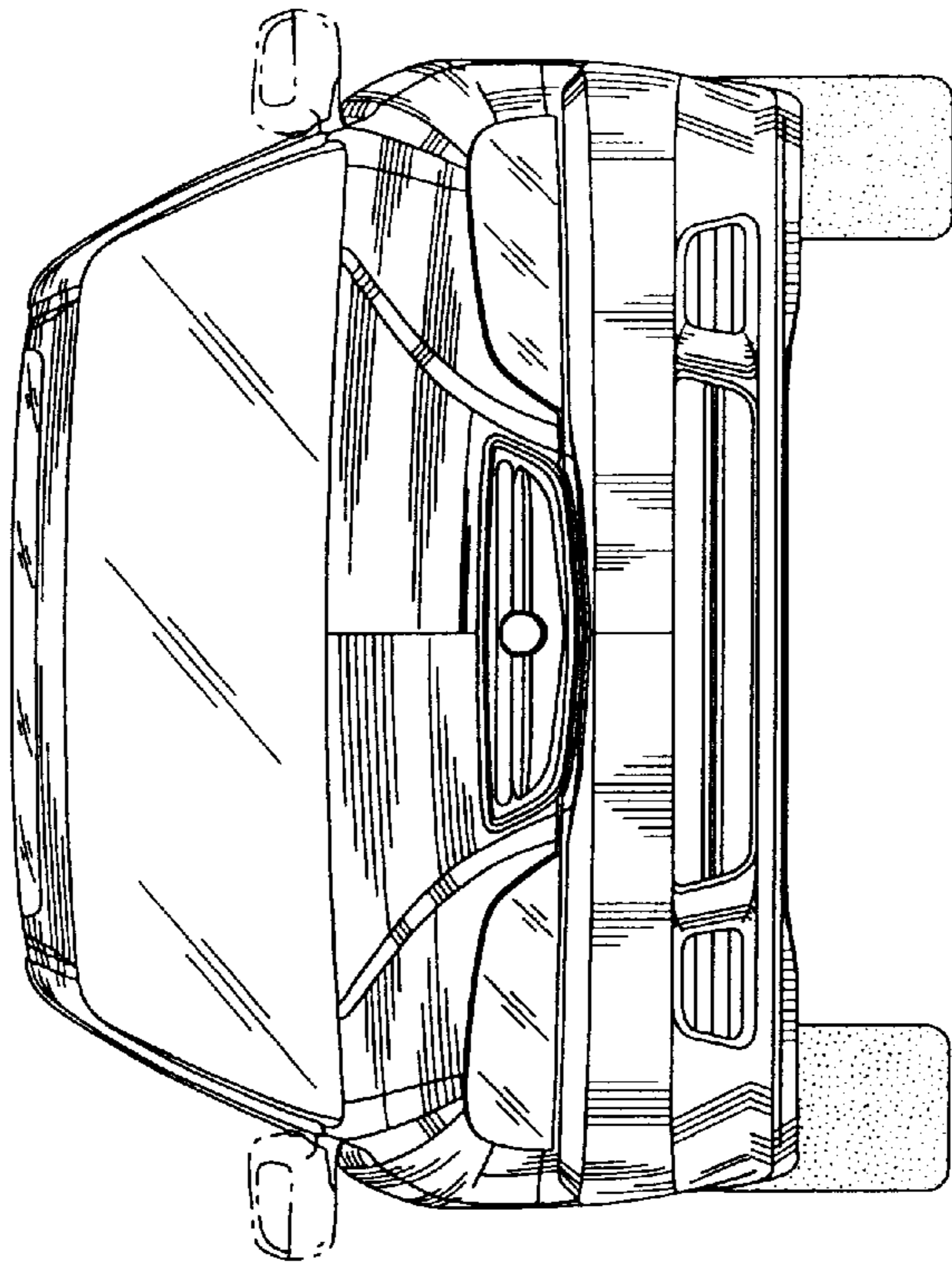

FIG. 3

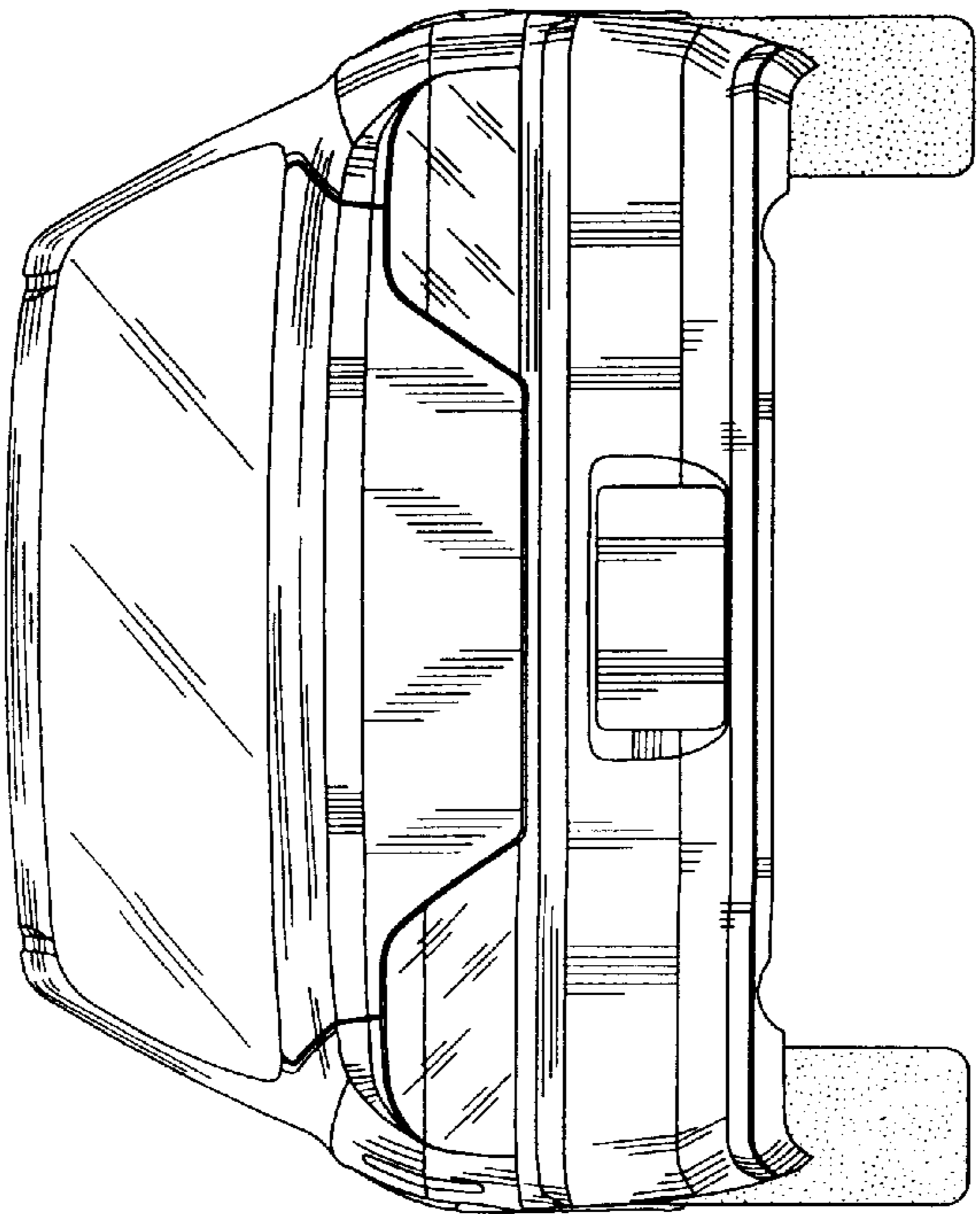

FIG. 4

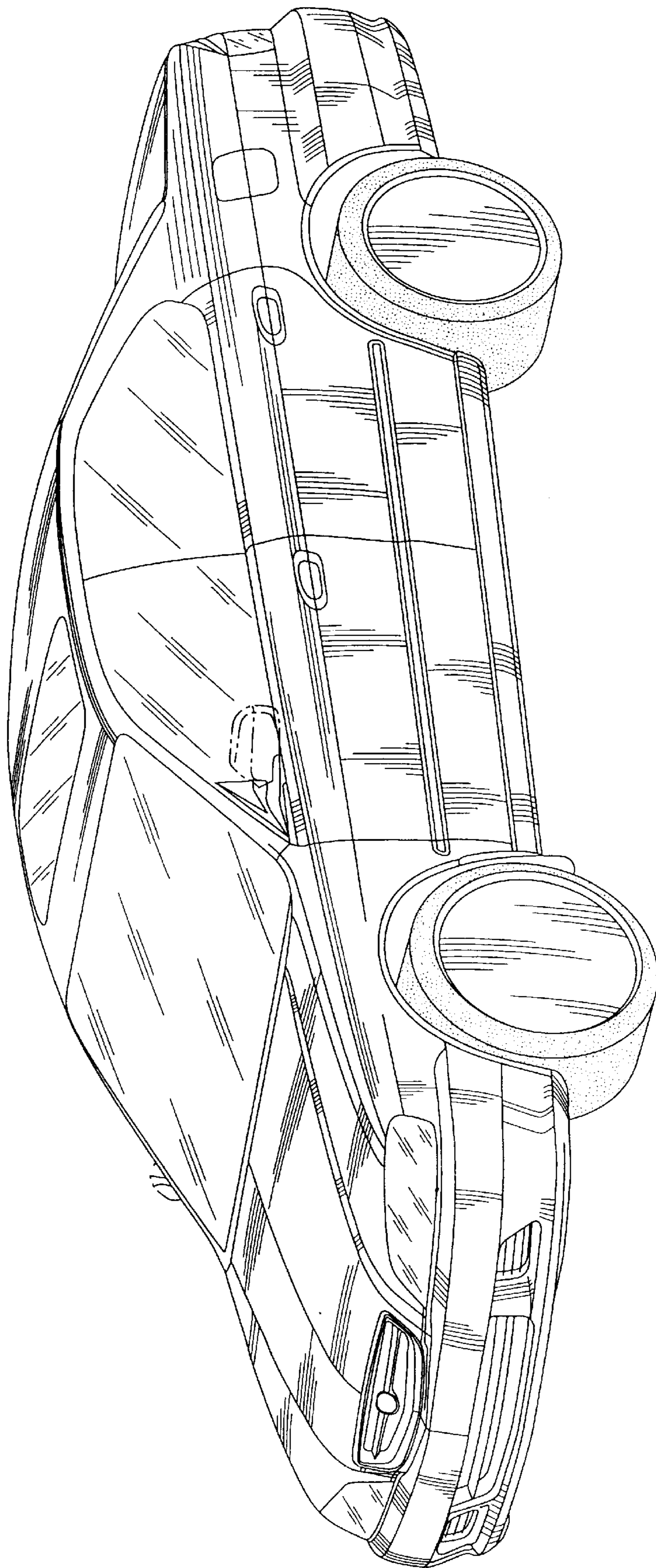

FIG. 5

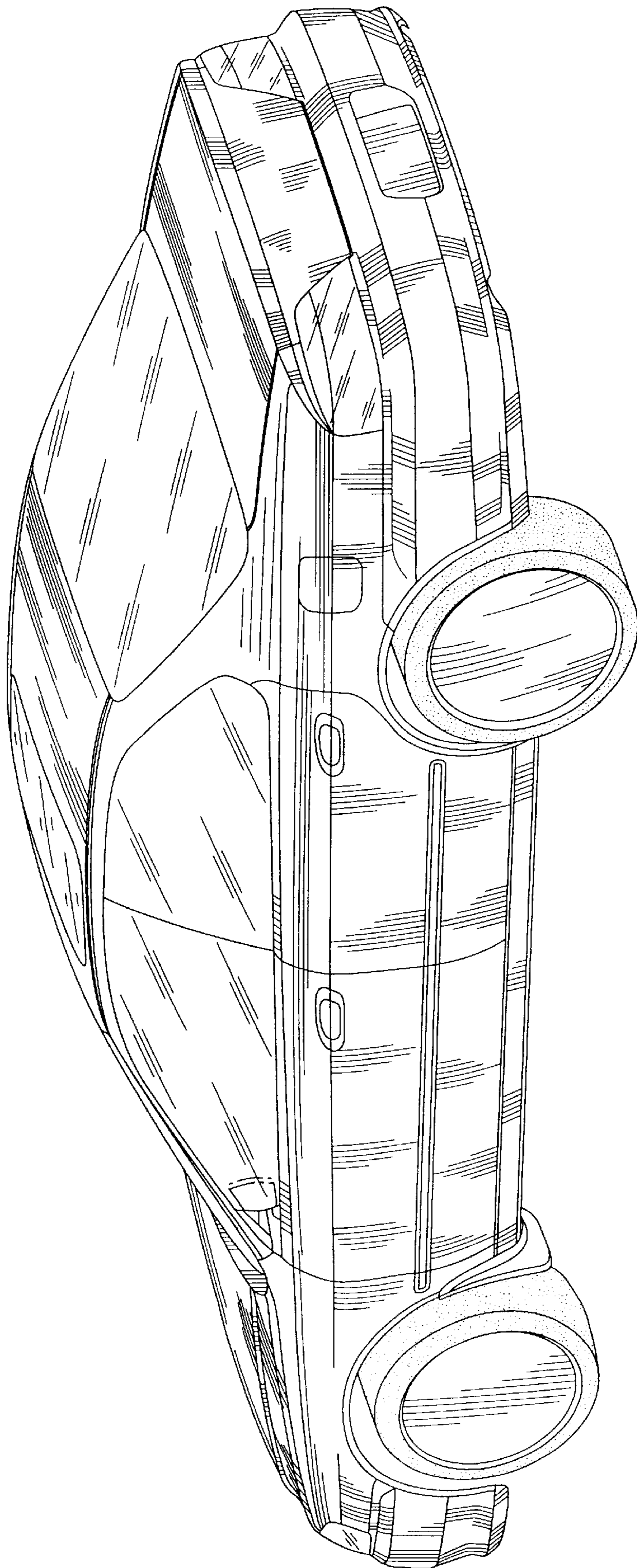

FIG. 6