



US00D437089S

(12) **United States Design Patent**  
**Newman**

(10) **Patent No.:** **US D437,089 S**

(45) **Date of Patent:** **\*\* Jan. 30, 2001**

(54) **RETRACTABLE NAIL FILE**

2,785,691 \* 3/1957 Anderson ..... 132/72.6

(76) Inventor: **Karla Newman**, 921 Ashley Glen Dr.,  
Winston-Salem, NC (US) 27104

\* cited by examiner

(\*\*) Term: **14 Years**

*Primary Examiner*—Dominic Simone  
(74) *Attorney, Agent, or Firm*—Charles Y. Lackey;  
Kilpatrick Stockton LLP

(21) Appl. No.: **29/105,201**

(57) **CLAIM**

(22) Filed: **May 20, 1999**

The ornamental design for a retractable nail file, as shown  
and described.

(51) **LOC (7) Cl.** ..... **28-02**

(52) **U.S. Cl.** ..... **D28/59; D8/100**

(58) **Field of Search** ..... D28/56, 59; D8/99,  
D8/100, 105; 30/156, 162; 132/76.4

**DESCRIPTION**

(56) **References Cited**

**U.S. PATENT DOCUMENTS**

- D. 307,106 \* 4/1990 Krebs ..... D8/99
- D. 331,643 \* 12/1992 Lunderman et al. .... D28/59
- D. 373,946 \* 9/1996 Sawano ..... D8/99
- D. 394,129 \* 5/1998 Litton ..... D28/59
- D. 399,404 \* 10/1998 Gullette ..... D8/100
- 2,284,168 \* 5/1942 Rickenbacher ..... 132/76.2
- 2,408,888 \* 10/1946 Shoop ..... 132/76.2
- 2,555,360 \* 6/1951 Murpyy ..... 132/76.2

FIG. 1 is a left side elevational view of a retractable nail file showing my new design;  
 FIG. 2 is a top plan view thereof;  
 FIG. 3 is a right side elevational view thereof;  
 FIG. 4 is a front elevational view thereof, the rear being identical;  
 FIG. 5 is a front elevational view thereof, the blade in an extended position;  
 FIG. 6 is a top plan view of FIG. 5; and,  
 FIG. 7 is left front perspective view of FIG. 5.

**1 Claim, 1 Drawing Sheet**

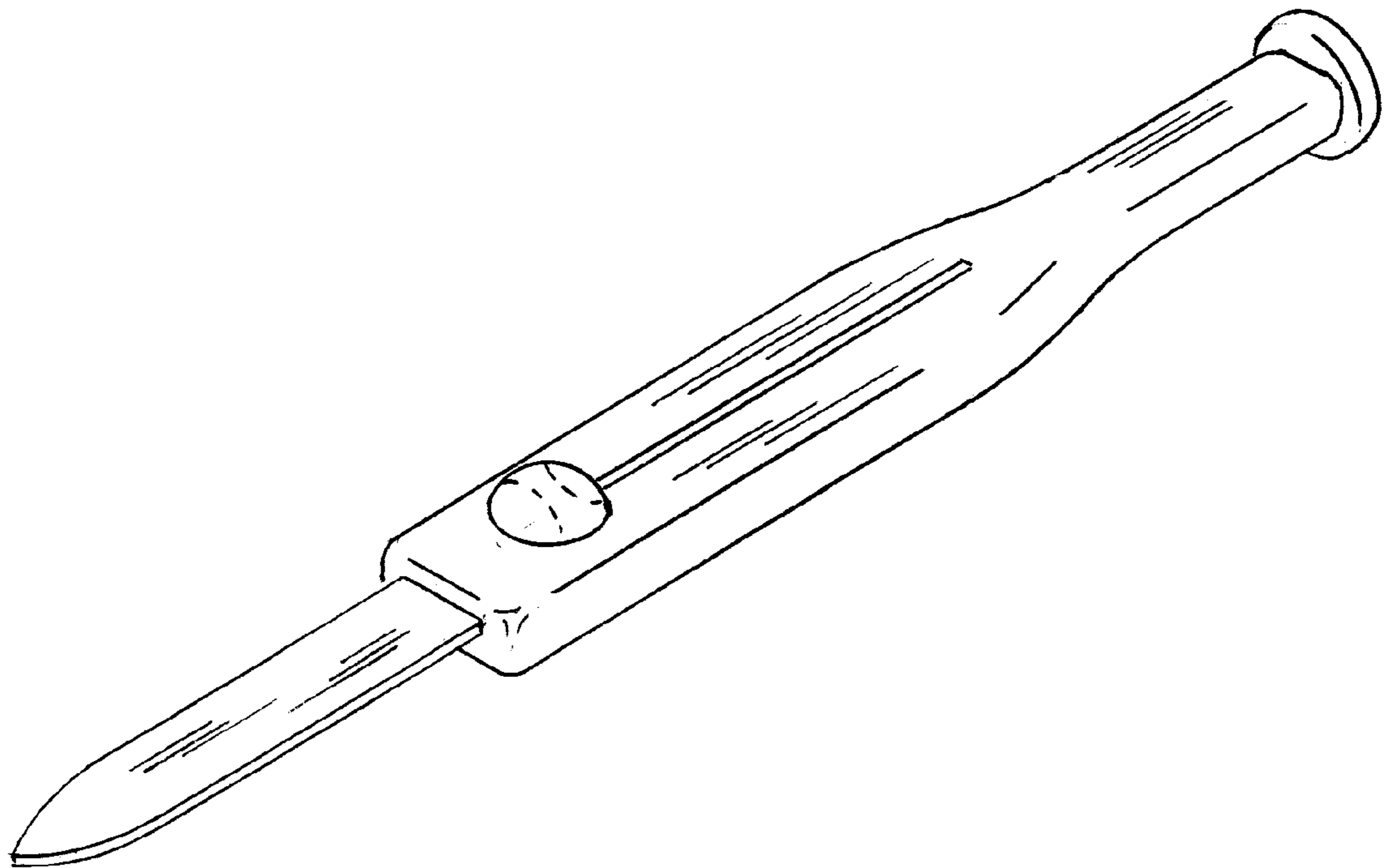



FIG. 1

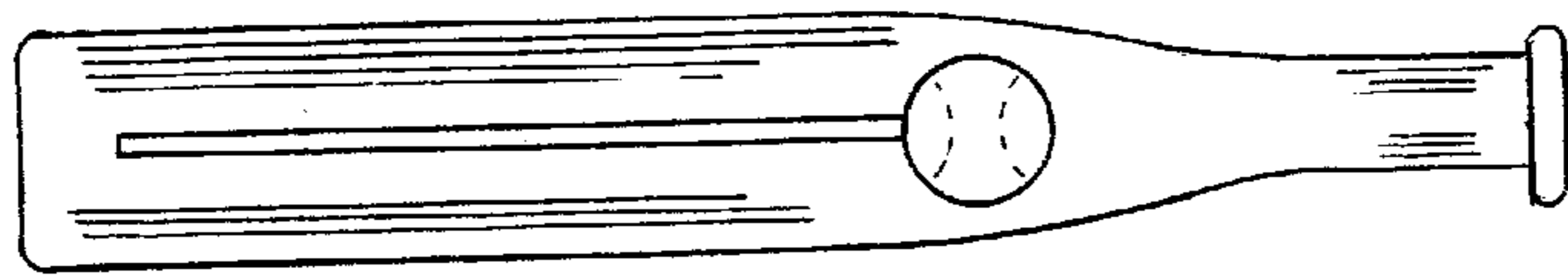

FIG. 2

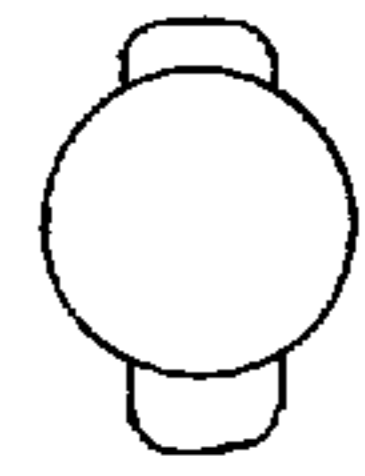

FIG. 3

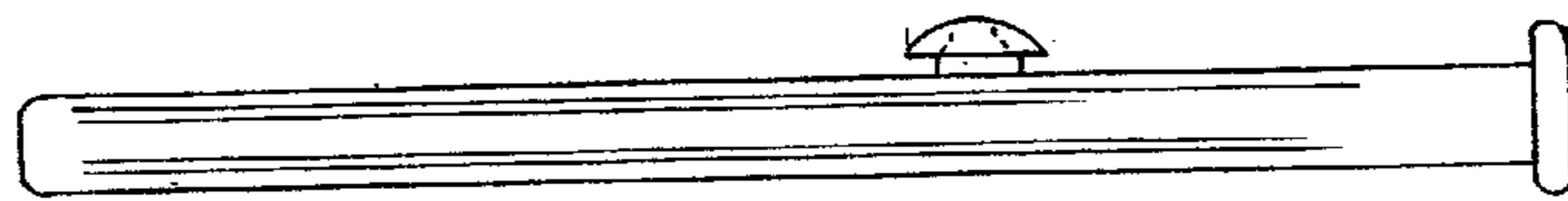

FIG. 4

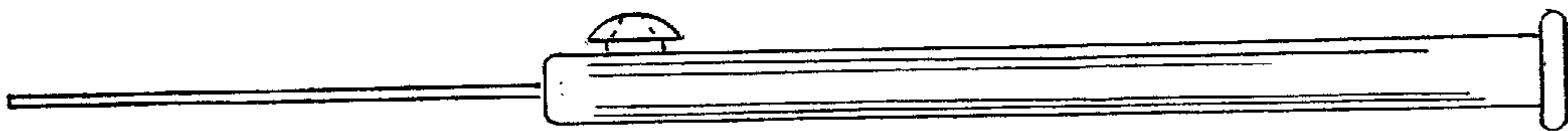

FIG. 5

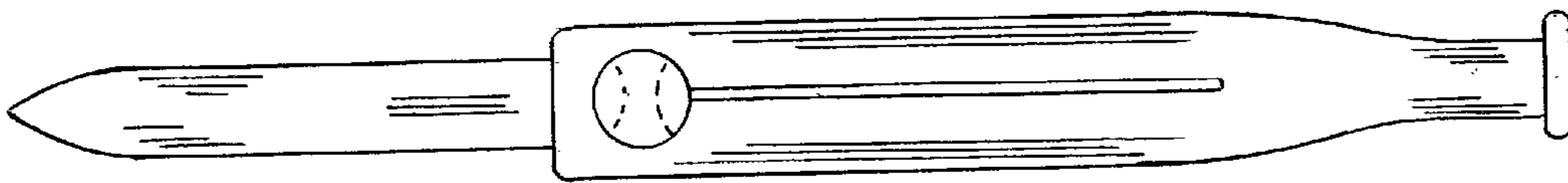

FIG. 6

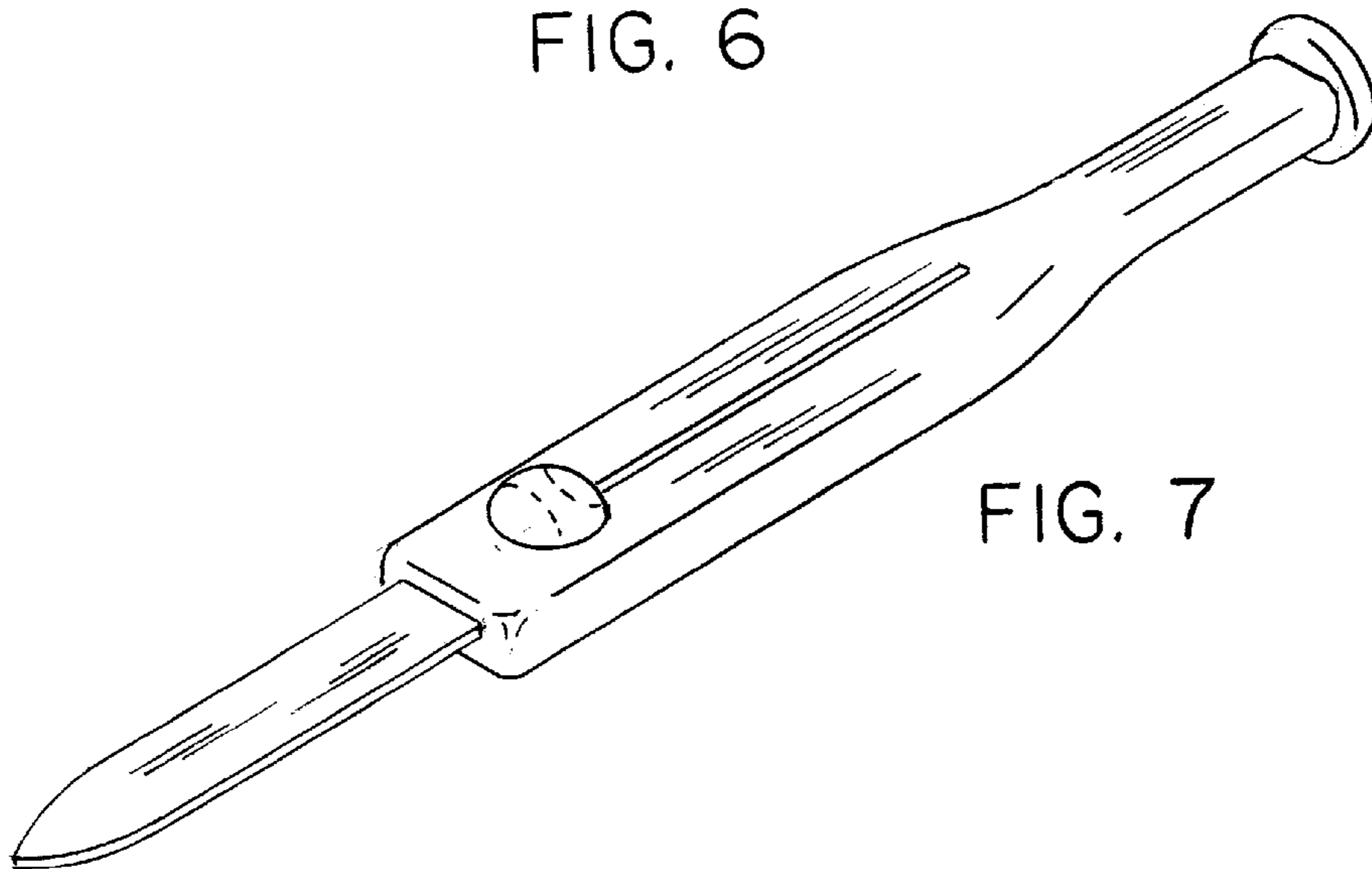

FIG. 7