



US00D436894S

(12) **United States Design Patent**  
**Barraclough et al.**

(10) **Patent No.: US D436,894 S**

(45) **Date of Patent: \*\* \*Jan. 30, 2001**

(54) **ROOF FOR A TRUCK**

(75) Inventors: **Robert S. Barraclough**, Flower Mound; **Kenneth H. Damon**, Fort Worth; **Louis D. Heilaneh**; **Daryl J. Sekishiro**, both of Lewisville, all of TX (US)

(73) Assignee: **Paccar INC**, Bellevue, WA (US)

(\* ) Notice: This patent is subject to a terminal disclaimer.

(\*\*) Term: **14 Years**

(21) Appl. No.: **29/105,116**

(22) Filed: **May 18, 1999**

(51) **LOC (7) Cl. .... 12-08**

(52) **U.S. Cl. .... D12/96**

(58) **Field of Search** ..... D12/96, 97, 99, D12/181; 180/89.12, 89.13-89.16, 89.19; 296/180.1-180.3, 190

(56) **References Cited**

**U.S. PATENT DOCUMENTS**

D. 248,846	8/1978	Stage et al. ....	D12/156
D. 271,864	12/1983	Kangas .....	D12/96
D. 272,058	1/1984	Kangas .....	D12/156
D. 296,775	7/1988	Hatch et al. ....	D12/181
D. 305,746	1/1990	Allendorph .....	D12/96
D. 307,731	5/1990	Kerney et al. ....	D12/96
D. 308,032	5/1990	Kerney et al. ....	D12/96
D. 311,506	10/1990	Marlowe et al. ....	D12/96
D. 311,712	10/1990	Marlowe et al. ....	D12/96
D. 312,805	12/1990	Marlowe et al. ....	D12/96
D. 313,966	1/1991	Marlowe et al. ....	D12/181
D. 320,583	10/1991	Simons et al. ....	D12/96
D. 329,214	9/1992	Marlowe et al. ....	D12/96

D. 335,855	5/1993	Callaway et al. ....	D12/181
D. 343,597	1/1994	Meryman et al. ....	D12/97
D. 343,819	2/1994	Meryman et al. ....	D12/181
D. 384,914	10/1997	Bingaman .....	D12/97
D. 391,524	3/1998	Anderson et al. ....	D12/96
D. 399,791	10/1998	Hellhake et al. ....	D12/96
D. 399,792	10/1998	Hellhake et al. ....	D12/96
D. 400,158	10/1998	Meryman et al. ....	D12/401
D. 425,450 *	5/1999	Barraclough et al. ....	D12/96
4,750,772	6/1988	Haegert .....	296/1 S
4,775,179	10/1988	Riggs .....	296/180.2
4,883,307	11/1989	Hacker et al. ....	296/180.2
4,957,322	9/1990	Marlowe et al. ....	296/180.2
5,560,673	10/1996	Angelo .....	296/190
5,603,549	2/1997	Chen et al. ....	296/180.1
5,658,038	8/1997	Griffin .....	296/180.2

\* cited by examiner

*Primary Examiner*—Melody N. Brown

(74) *Attorney, Agent, or Firm*—Sidley & Austin

(57) **CLAIM**

The ornamental design for a roof for a truck, as shown and described.

**DESCRIPTION**

FIG. 1 is a perspective view of our roof for a truck; FIG. 2 is a front view thereof; FIG. 3 is a left side view thereof; FIG. 4 is a rear view thereof; FIG. 5 is a right side view thereof; FIG. 6 is a top view thereof; and, FIG. 7 is a reduced perspective view of our design.

The appearance of the roof underside forms no part of the claimed design. In addition, the broken line showing of a truck, in FIG. 7, depicts environment and is not part of the claimed design.

**1 Claim, 3 Drawing Sheets**

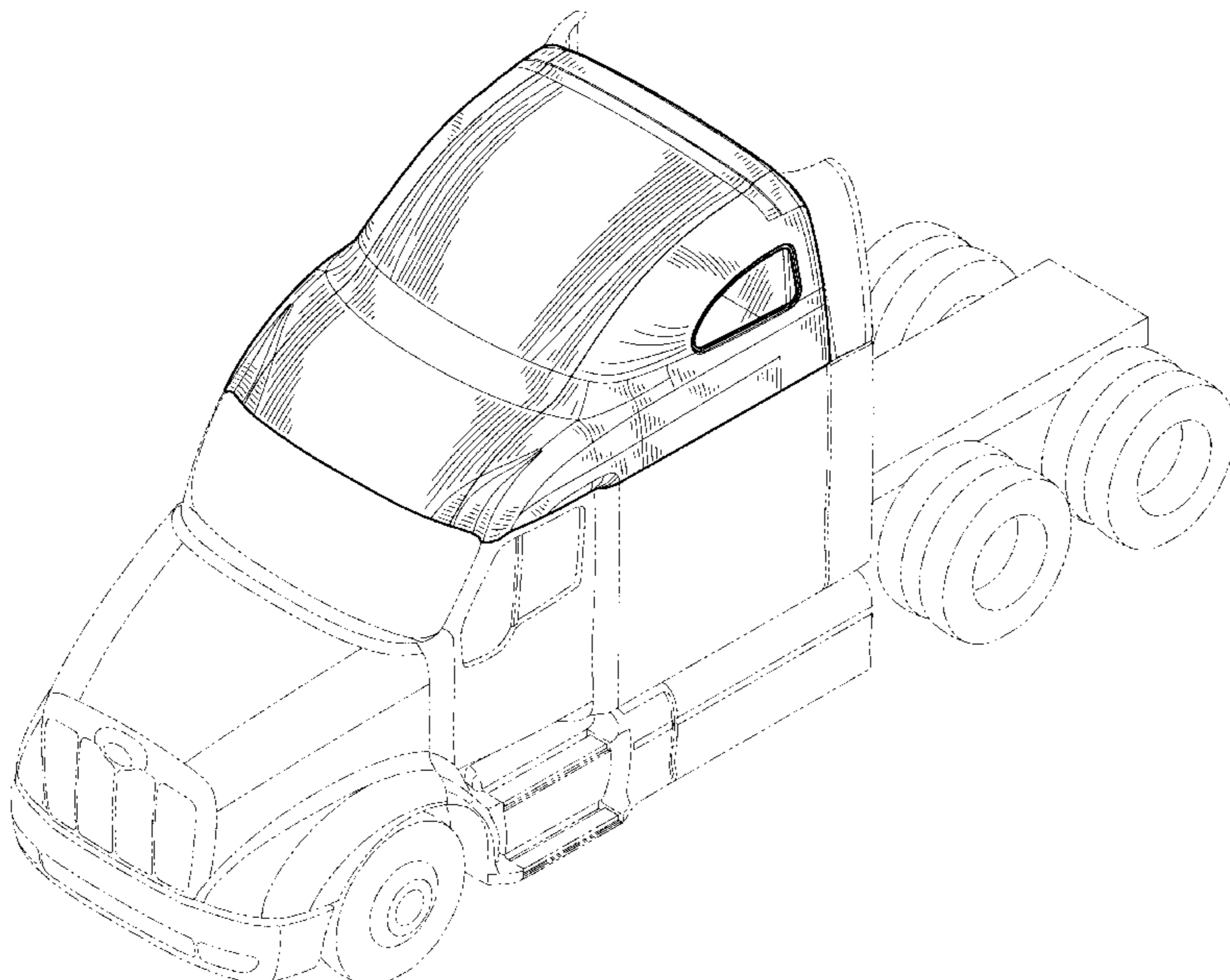

*FIG. 1*

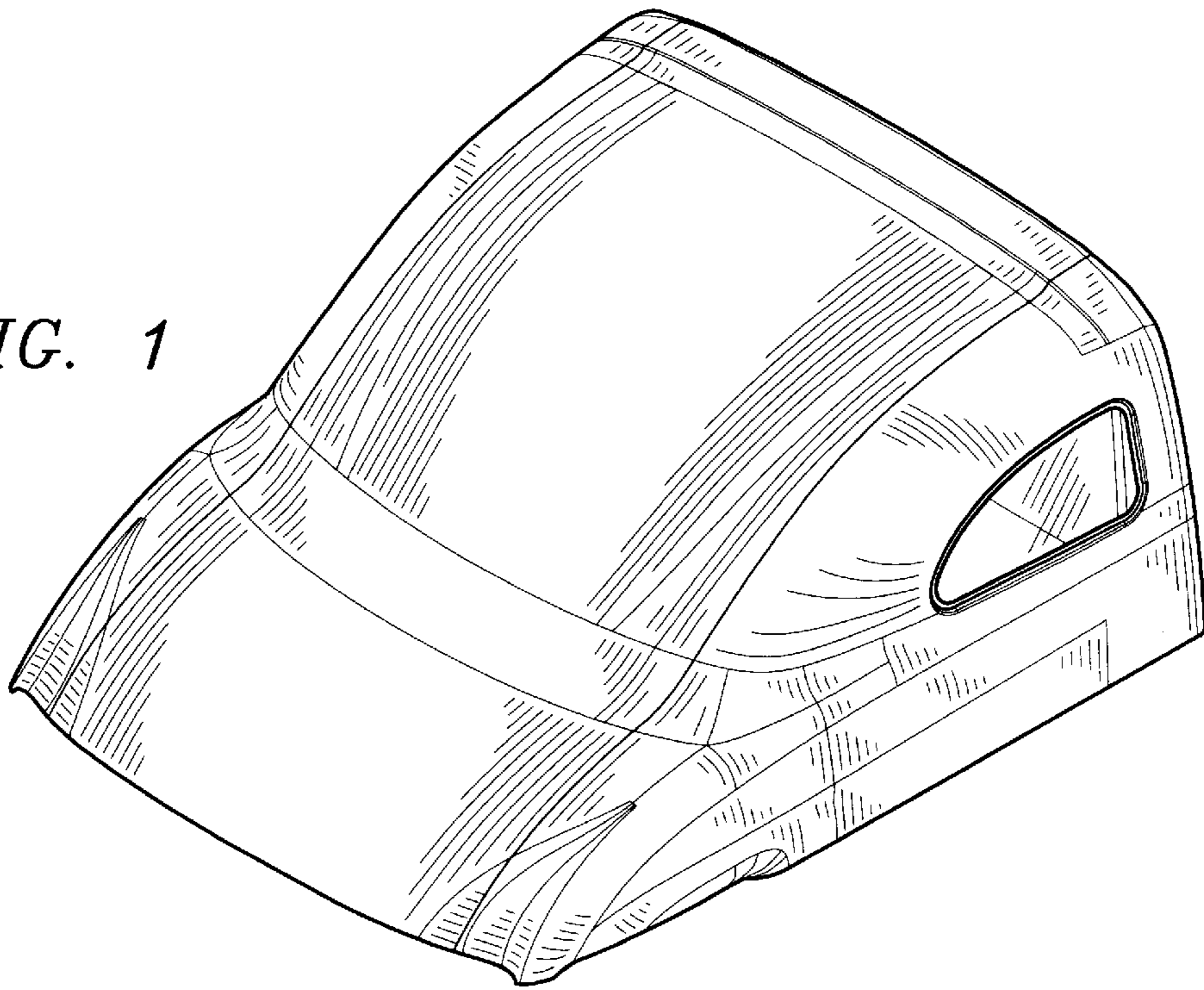

*FIG. 2*

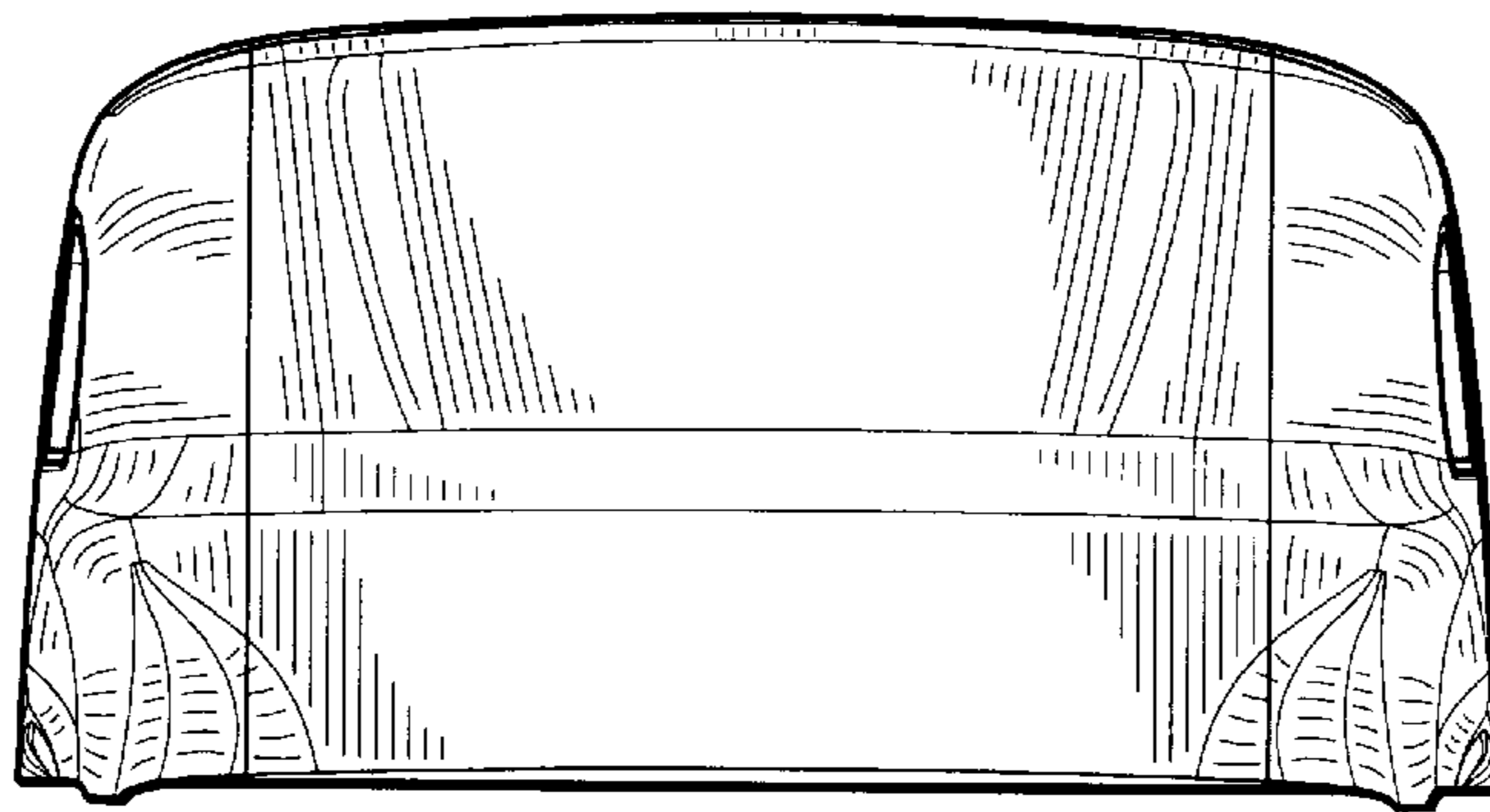

*FIG. 3*

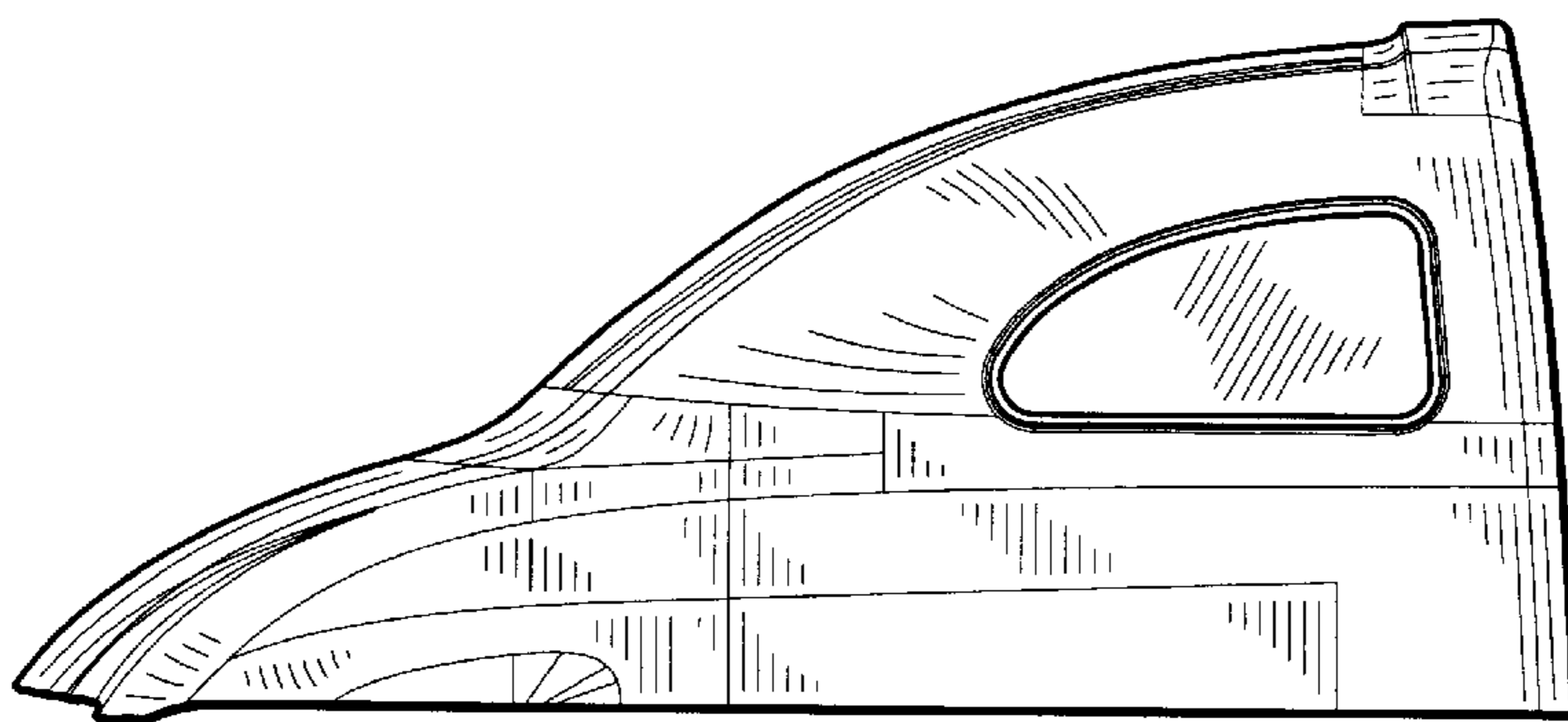

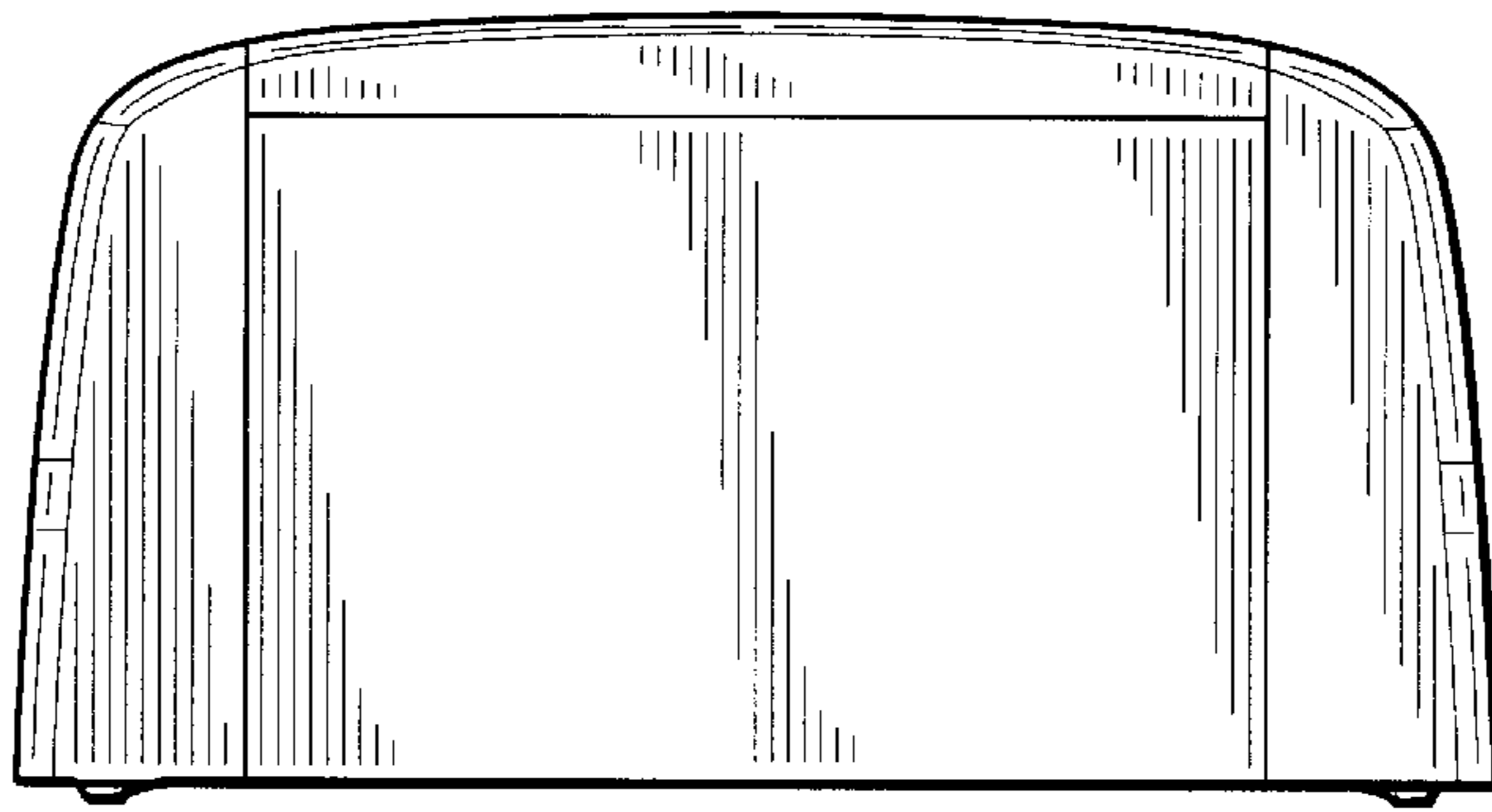

FIG. 4

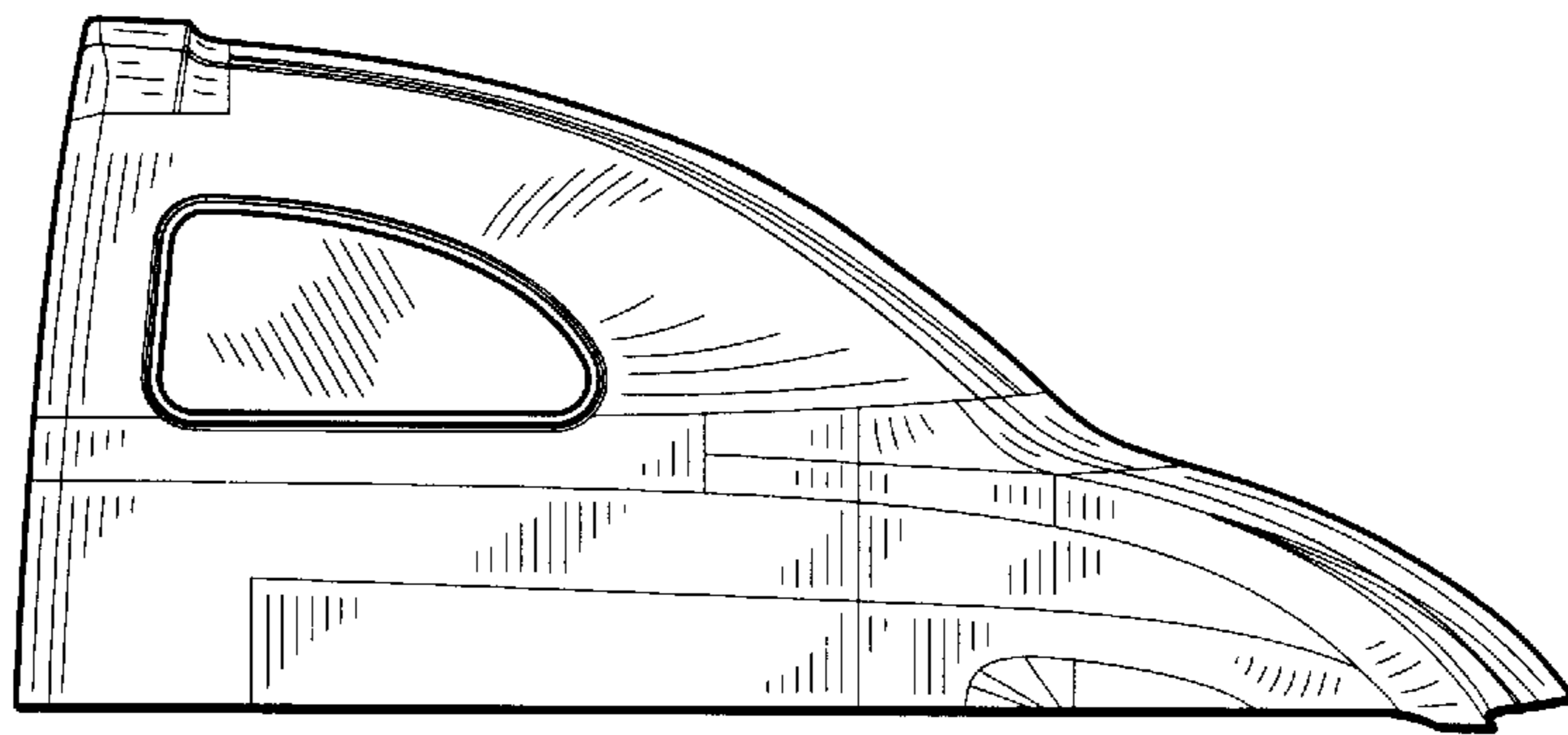

FIG. 5

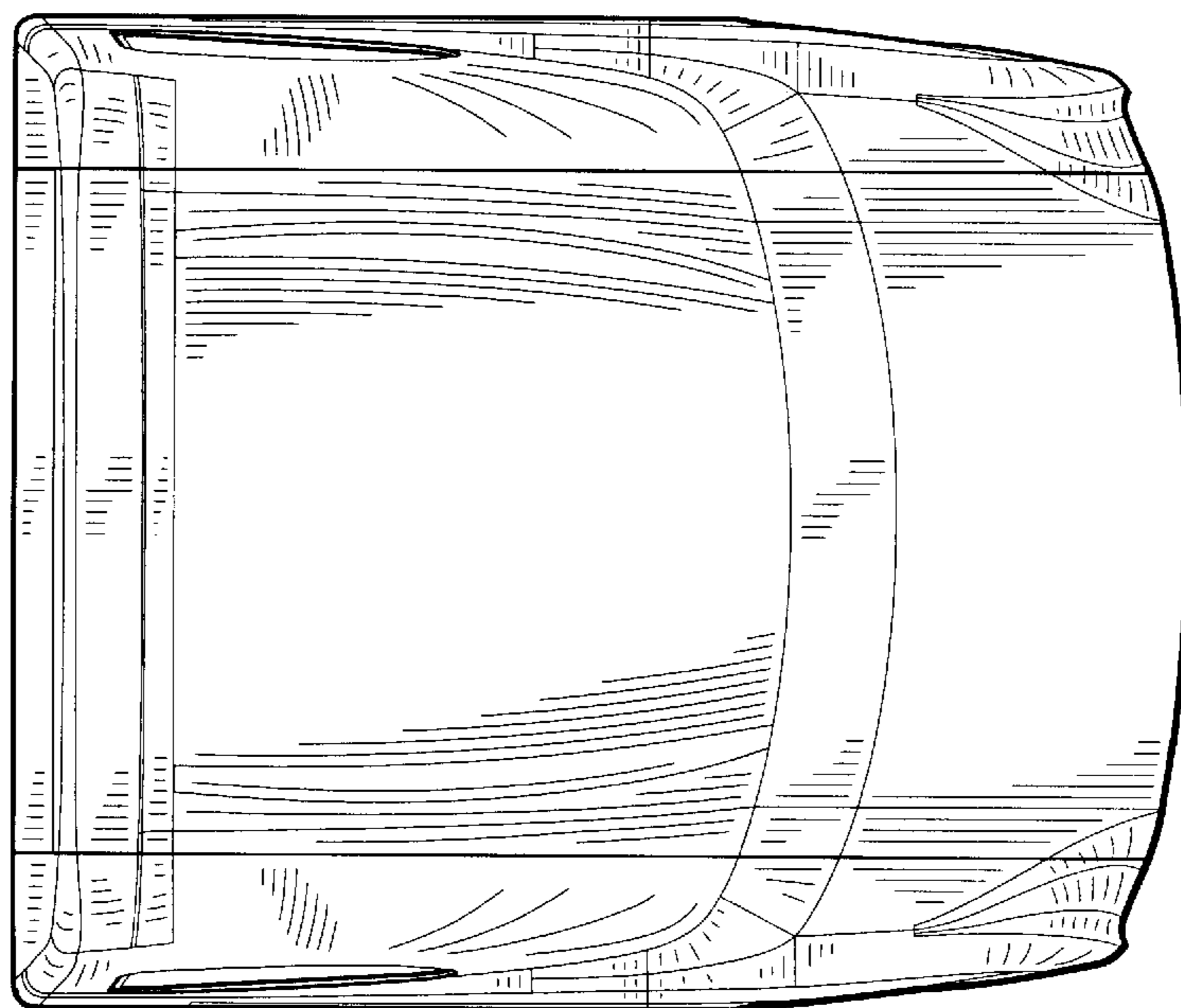

FIG. 6

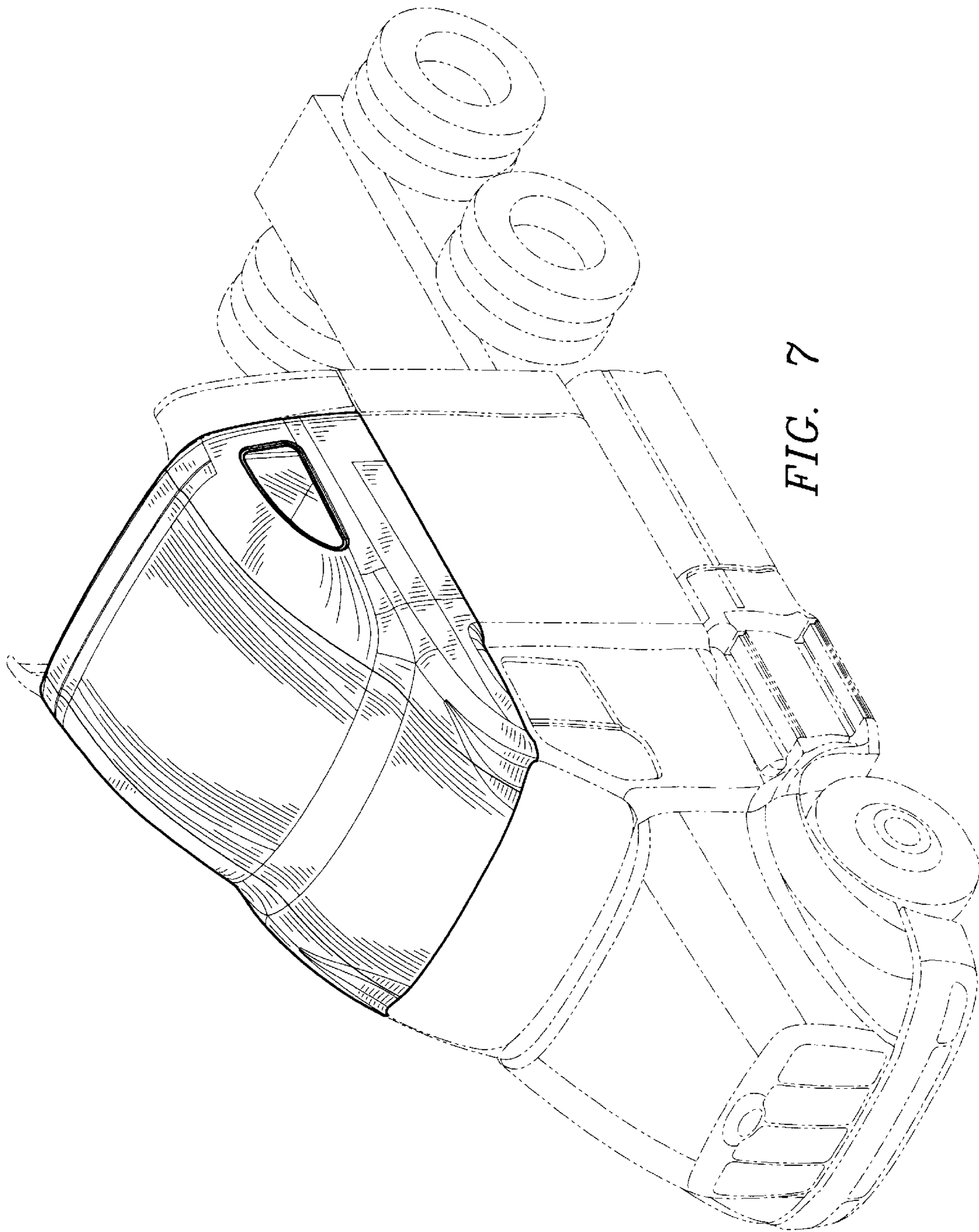

FIG. 7

UNITED STATES PATENT AND TRADEMARK OFFICE  
Certificate

Patent No. D 436,894 S

Patented: January 30, 2001

On petition requesting issuance of a certificate for correction of inventorship pursuant to 35 U.S.C. 256, it has been found that the above identified patent, through error and without any deceptive intent, improperly sets forth the inventorship.

Accordingly, it is hereby certified that the correct inventorship of this patent is: Robert S. Barraclough, Flower Mound, TX; Kenneth H. Damon, Fort Worth, TX; Louis D. Heilaneh, Lewisville, TX; Daryl J. Sekishiro, Lewisville, TX; and Joseph F. Marrs, Denton, TX.

Signed and Sealed this First Day of April 2003.

ALAN P. DOUGLAS  
*Supervisory Patent Examiner*  
Art Unit 2911