



US00D436709S

(12) **United States Design Patent**
Lux, Jr.

(10) **Patent No.:** **US D436,709 S**

(45) **Date of Patent:** **** Jan. 23, 2001**

(54) **PAD FOR TRANSPORTING MULTIPLE TRANSFORMERS**

(75) **Inventor:** **Robert J. Lux, Jr.**, Broken Arrow, OK (US)

(73) **Assignee:** **Shan Industries L.L.C.**, Washington, DC (US)

(*) **Notice:** This patent is subject to a terminal disclaimer.

(**) **Term:** **14 Years**

(21) **Appl. No.:** **29/103,710**

(22) **Filed:** **Apr. 20, 1999**

(51) **LOC (7) Cl.** **09-08**

(52) **U.S. Cl.** **D34/38**

(58) **Field of Search** D34/38; 108/51.1, 108/53.1, 56.1, 56.3, 52.1, 54.1, 55.3, 57.1; 248/346.1

(56) **References Cited**

U.S. PATENT DOCUMENTS

D. 217,860	*	6/1970	Bartee et al.	D34/38
D. 228,896	*	10/1973	Melnick et al.	D34/38
D. 229,042	*	11/1973	Melnick et al.	D34/38
D. 229,486	*	12/1973	Roper	D34/38
D. 264,066	*	4/1982	Smith et al.	D34/38
D. 320,880	*	10/1991	Brunin	D34/38
D. 379,021	*	4/1997	Wies	D34/38
2,652,219	*	9/1953	Arthur	108/51.1

2,704,600	*	3/1955	Despres	108/56.1
3,424,110	*	1/1969	Toot	108/56.1
3,720,176	*	3/1973	Munroe	108/53.1
3,750,596	*	8/1973	Box	108/51.1
3,868,915	*	3/1975	Hafner	108/51.1
3,948,190	*	4/1976	Cook, III et al.	108/53.1
4,263,855	*	4/1981	Lawlor	108/53.3
5,142,994	*	9/1992	Sandberg et al.	108/53.3
5,769,003	*	6/1998	Rose et al.	108/55.3
5,833,207		11/1998	Hagenhoff et al.	248/678
5,857,416	*	1/1999	Donnell, Jr. et al.	108/55.3

* cited by examiner

Primary Examiner—Cynthia E. Ramirez

(74) *Attorney, Agent, or Firm*—Head, Johnson & Kachigian

(57) **CLAIM**

The ornamental design for a pad for transporting multiple transformers, as shown and described.

DESCRIPTION

FIG. 1 is an isometric view of one perspective of my design showing my pad for transporting multiple transformers.

FIG. 2 is an isometric view of another perspective of my design.

FIG. 3 is a top plan view of my design.

FIG. 4 is an elevational view of one side of my design, the opposite elevational side view being the same.

FIG. 5 is an elevational view of another side of my design, the opposite elevational side view being the same; and,

FIG. 6 is a bottom view of my design.

1 Claim, 3 Drawing Sheets

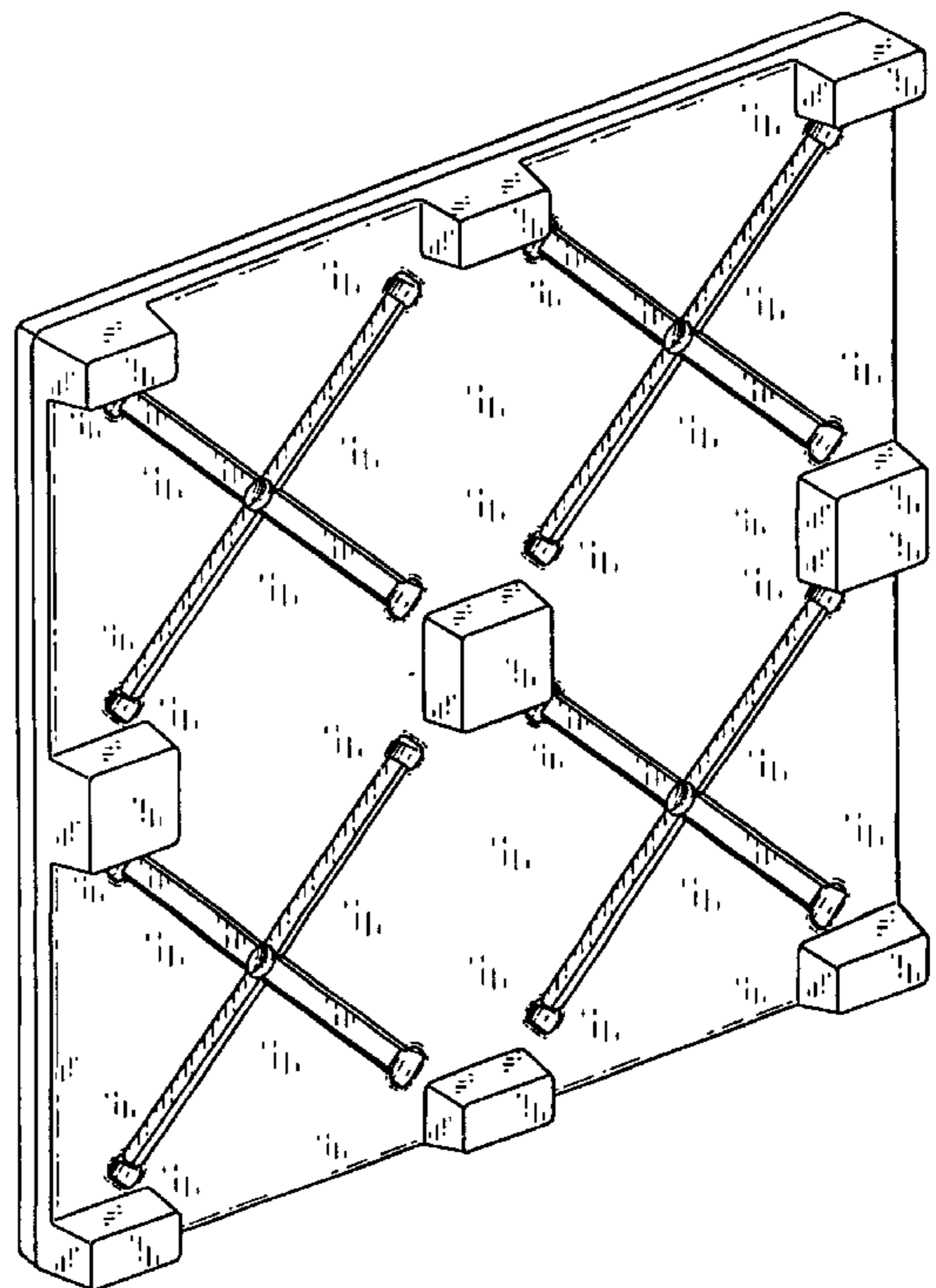
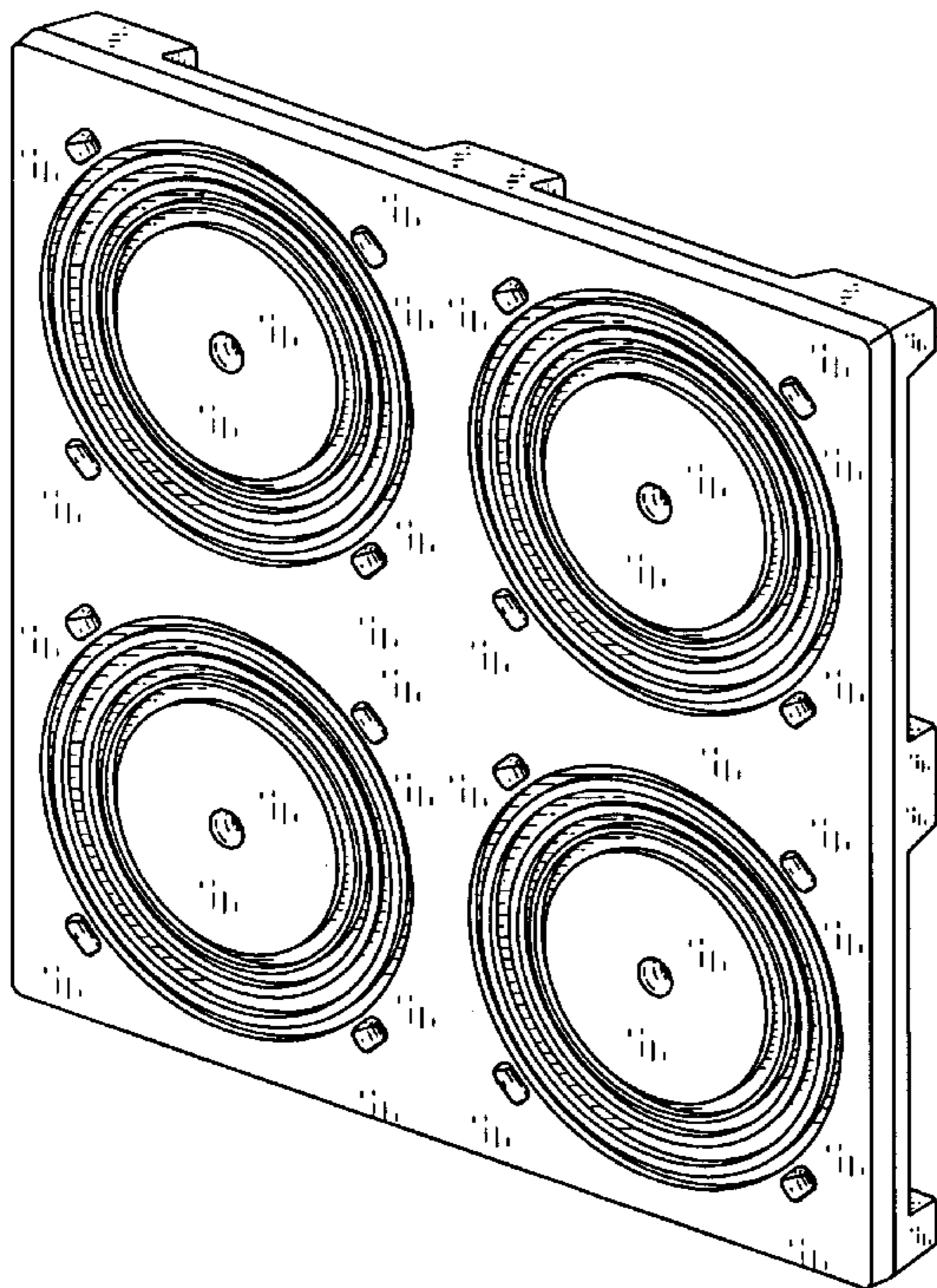

FIG. 1

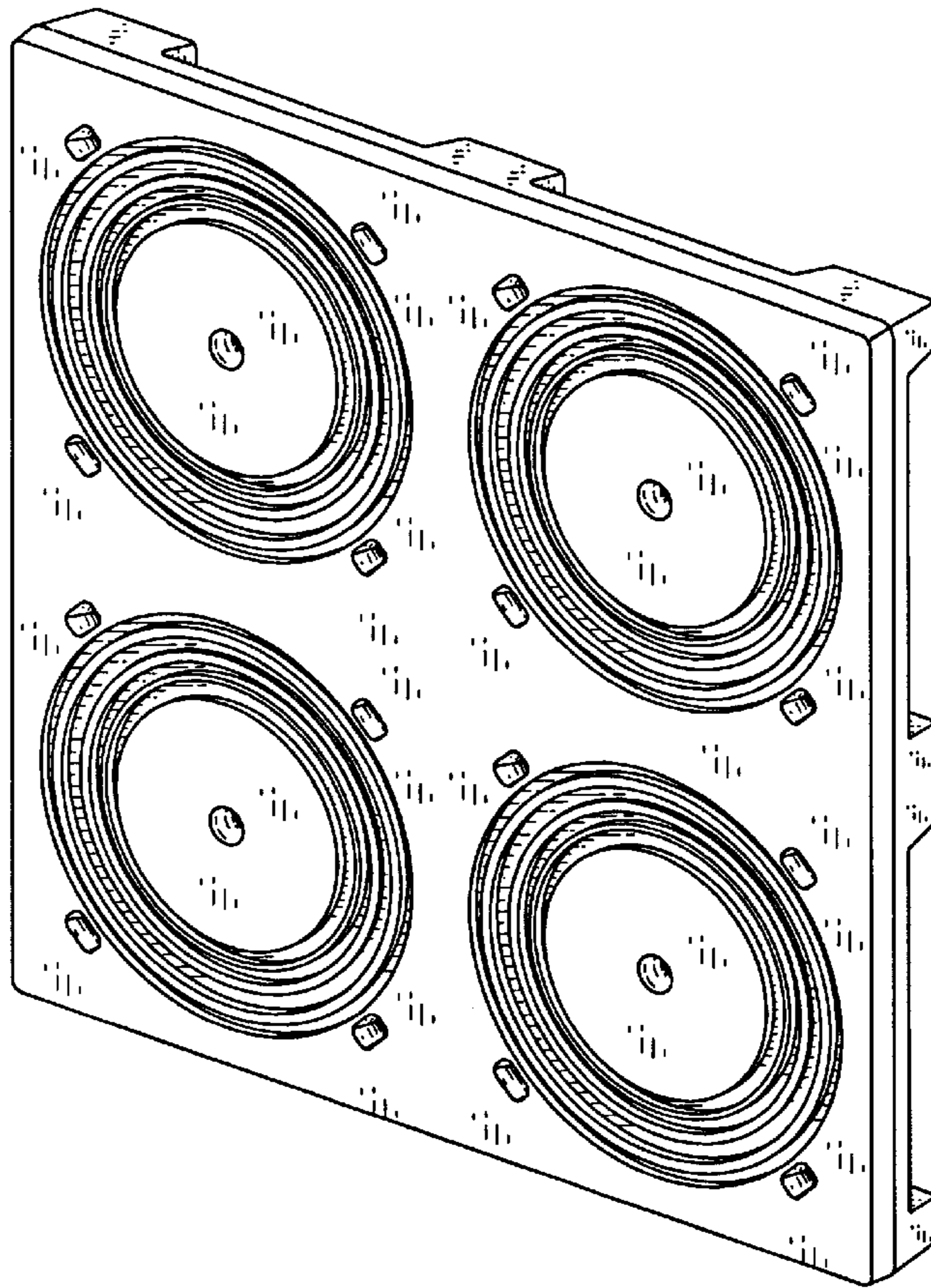

FIG. 2

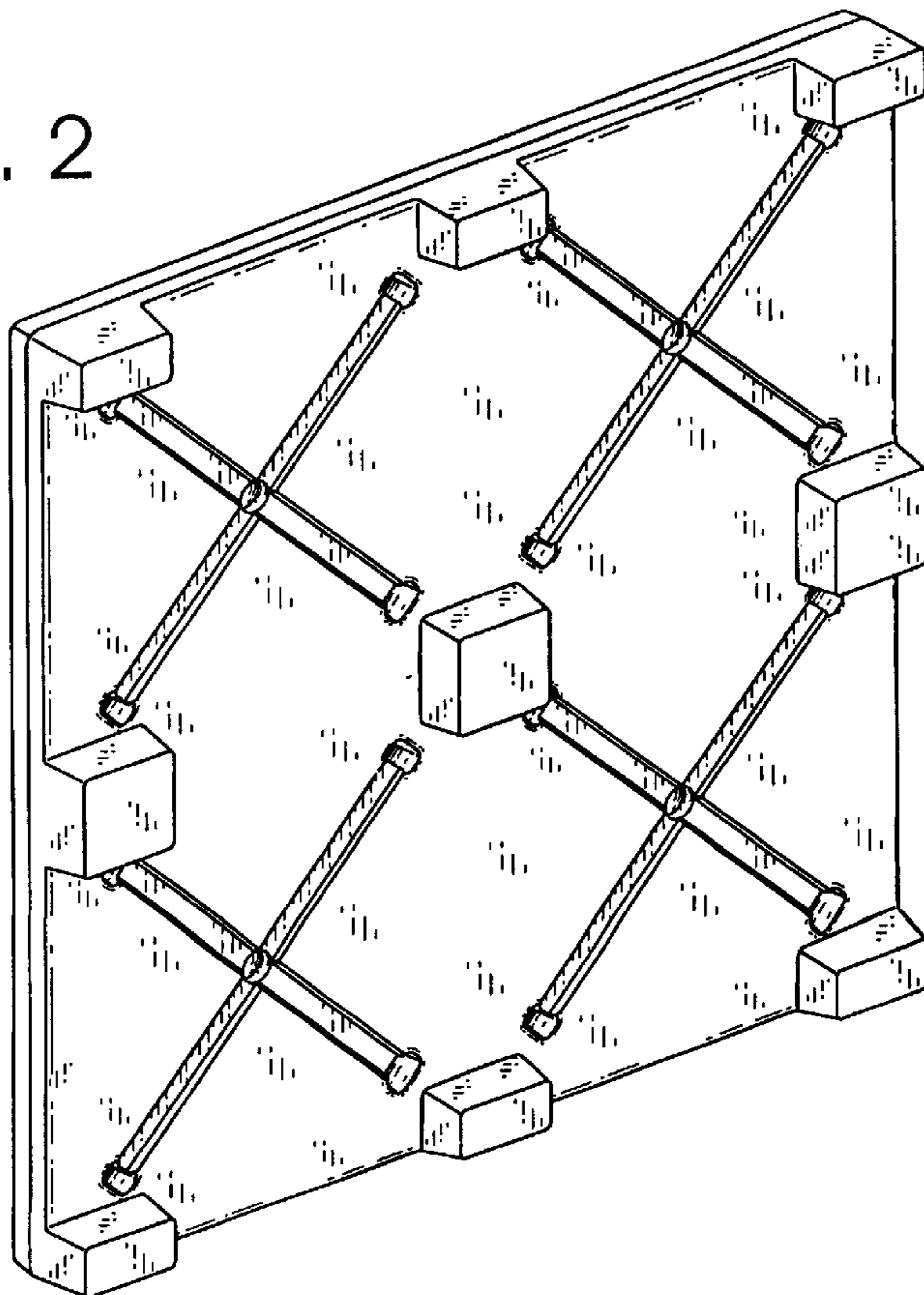

FIG. 3

FIG. 4

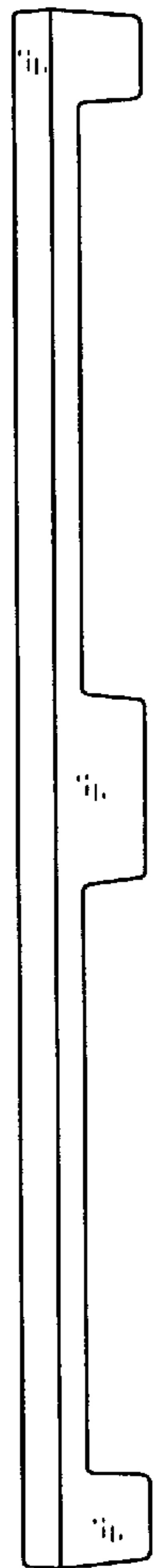
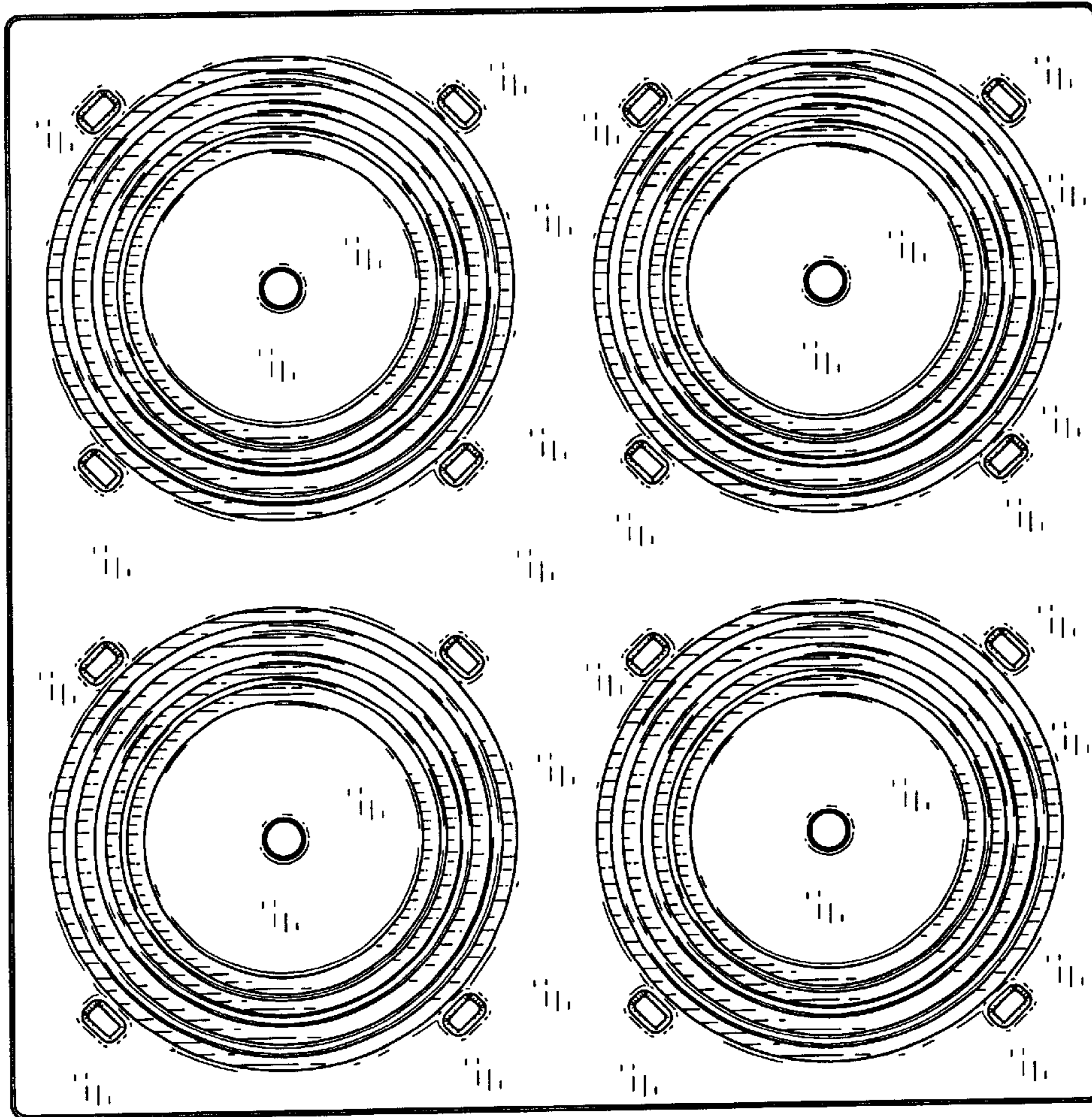

FIG. 5

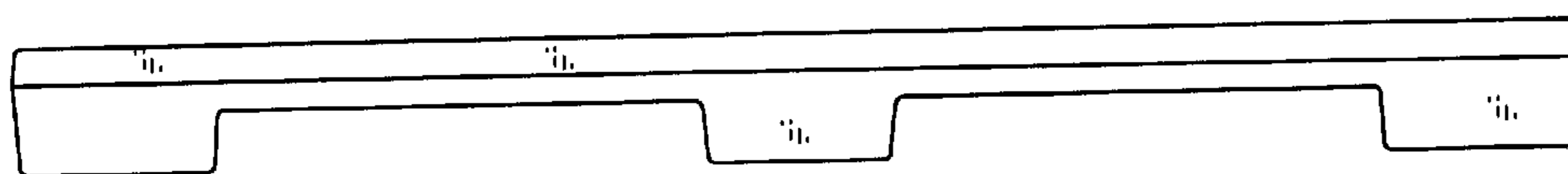

FIG. 6

