



US00D436511S

(12) **United States Design Patent**
Hayakawa et al.

(10) **Patent No.:** **US D436,511 S**

(45) **Date of Patent:** **** Jan. 23, 2001**

(54) **PORTABLE ELECTRIC DRILL**

(75) Inventors: **Naohiro Hayakawa; Takao Kuroyanagi**, both of Anjo (JP)

(73) Assignee: **Makita Corporation**, Anjo (JP)

(**) Term: **14 Years**

(21) Appl. No.: **29/126,356**

(22) Filed: **Jul. 11, 2000**

(30) **Foreign Application Priority Data**
Jan. 12, 2000 (JP) 12-002857

(51) **LOC (7) Cl.** **08-05**

(52) **U.S. Cl.** **D8/68**

(58) **Field of Search** D8/61-70; 81/57.11, 81/429, 54, 57.42, 409, 436, 900, 901, 439, 177.1, 57.14, 177.85; 173/170, 48, 213, 217, 171; 408/241.5, 20; 451/357-359

(56) **References Cited**

U.S. PATENT DOCUMENTS

D. 362,167 * 9/1995 Zurwelle D8/68
D. 377,442 * 1/1997 Kikuchi D8/68
D. 378,268 * 3/1997 Schultz D8/68
D. 386,662 11/1997 Tozawa et al. .
D. 392,530 * 3/1998 Lui D8/68
D. 402,871 * 12/1998 Clowers et al. D8/68
D. 409,467 * 5/1999 Chung D8/68

D. 411,947 * 7/1999 Sugimoto et al. D8/68
D. 419,413 * 1/2000 Heun D8/68
D. 420,877 * 2/2000 Schultz D8/68
D. 421,883 3/2000 Watson et al. .
D. 421,884 3/2000 Hattori .
D. 421,885 3/2000 Zurwelle et al. .
D. 424,902 * 5/2000 Gildersleeve et al. D8/68
D. 426,126 * 6/2000 Schultz D8/68
D. 428,320 * 7/2000 Ohi et al. D8/68
D. 429,134 * 8/2000 Schultz et al. D8/68
5,451,127 * 9/1995 Chung 408/20

* cited by examiner

Primary Examiner—Jeffrey Asch

(74) *Attorney, Agent, or Firm*—Dennison, Scheiner, Schultz & Wakeman

(57) **CLAIM**

The ornamental design for a portable electric drill, as shown and described.

DESCRIPTION

FIG. 1 is a perspective view of a portable electric drill showing our new design;
FIG. 2 is a front elevation view thereof;
FIG. 3 is a rear elevation view thereof;
FIG. 4 is a left side elevation view thereof;
FIG. 5 is a right side elevation view thereof;
FIG. 6 is a top plan view thereof; and,
FIG. 7 is a bottom plan view thereof.

1 Claim, 5 Drawing Sheets

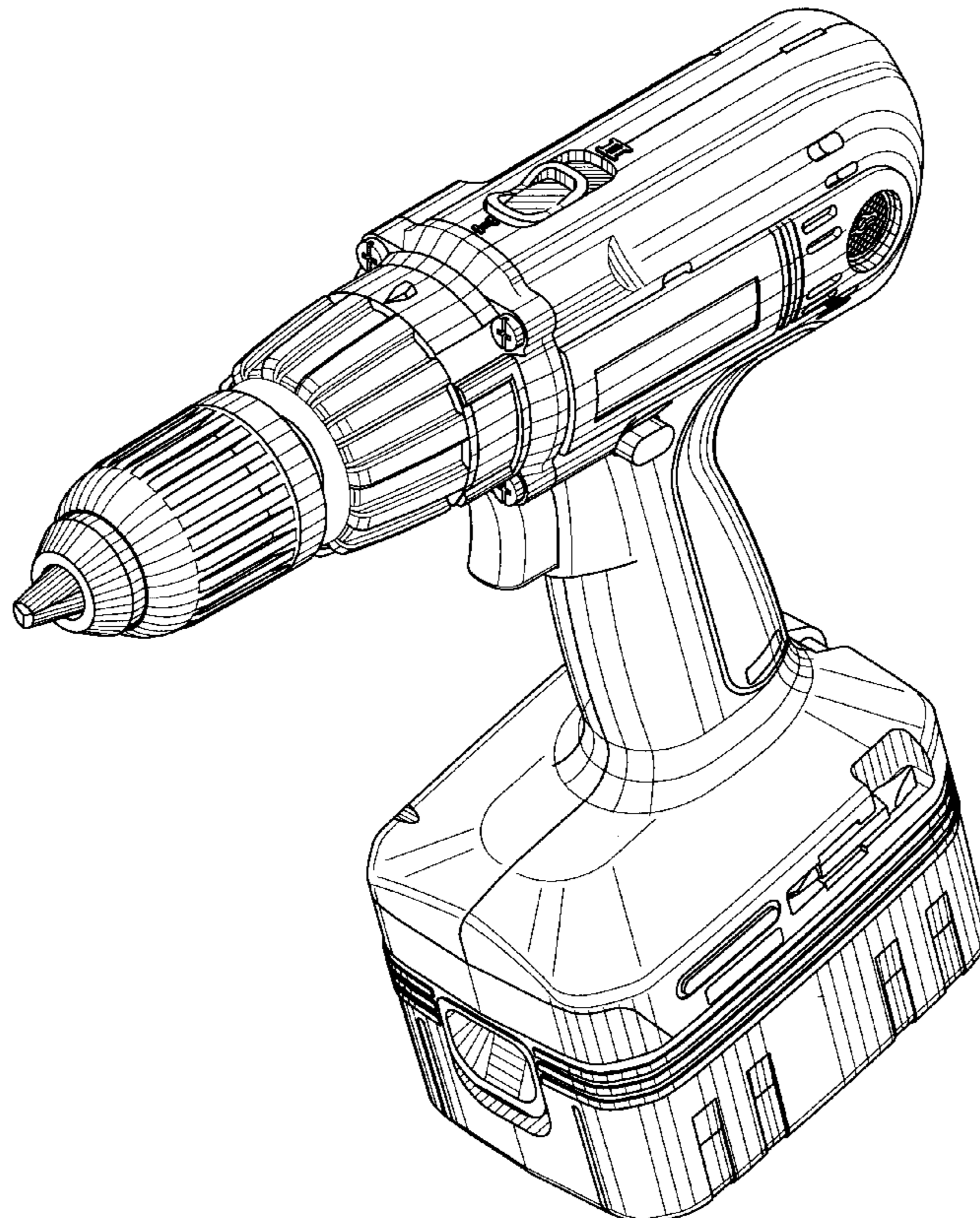

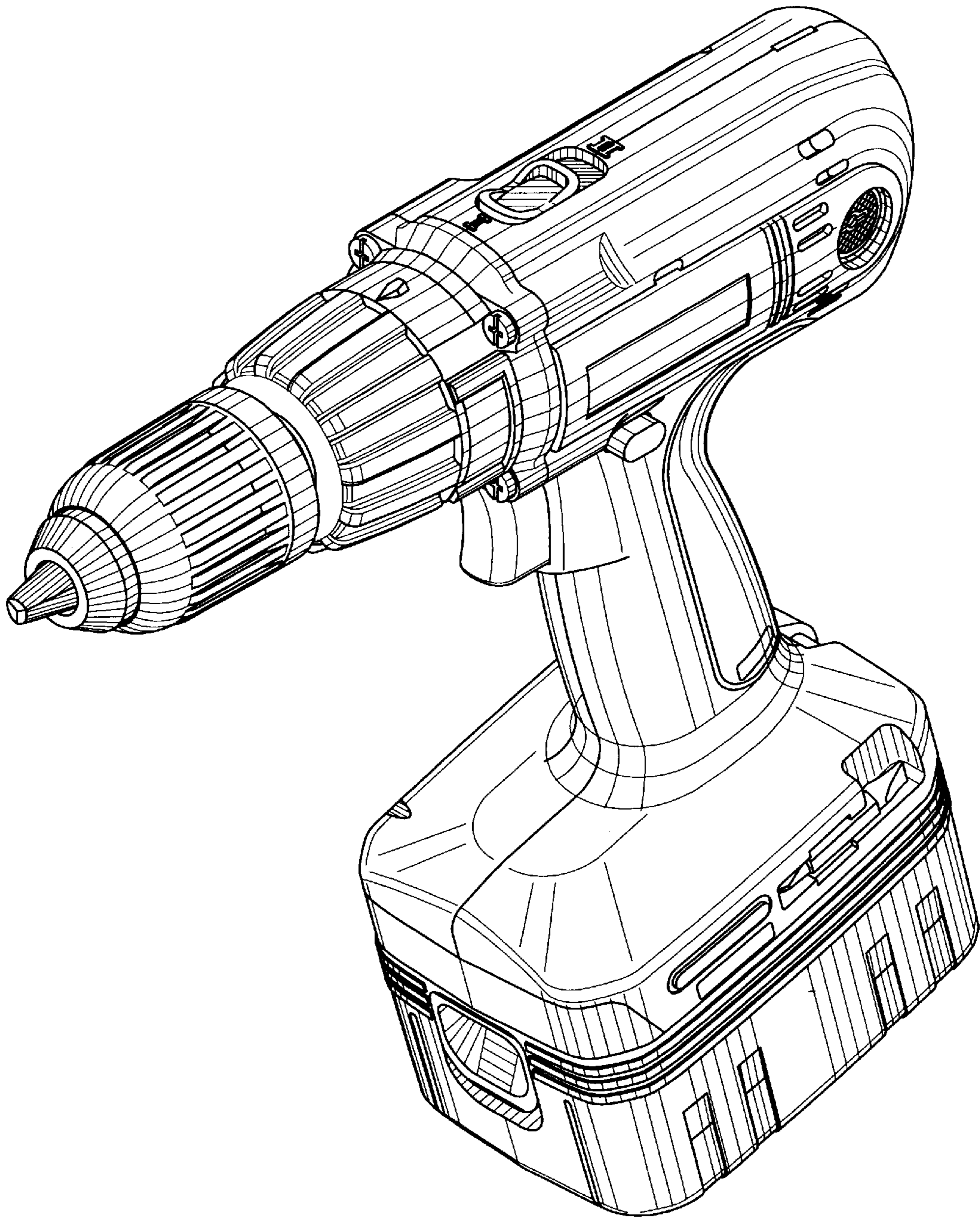

FIG. 1

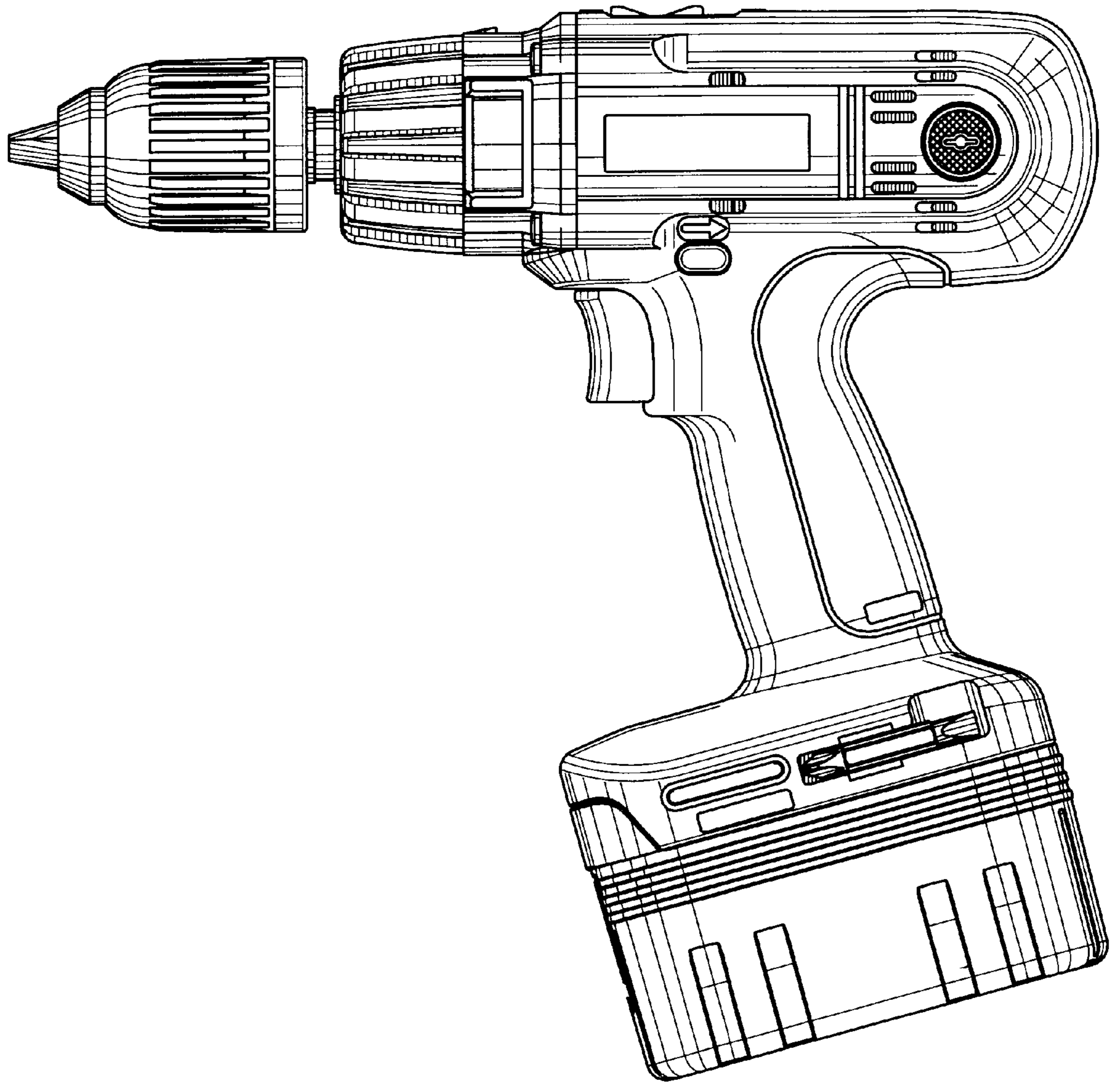

FIG. 2

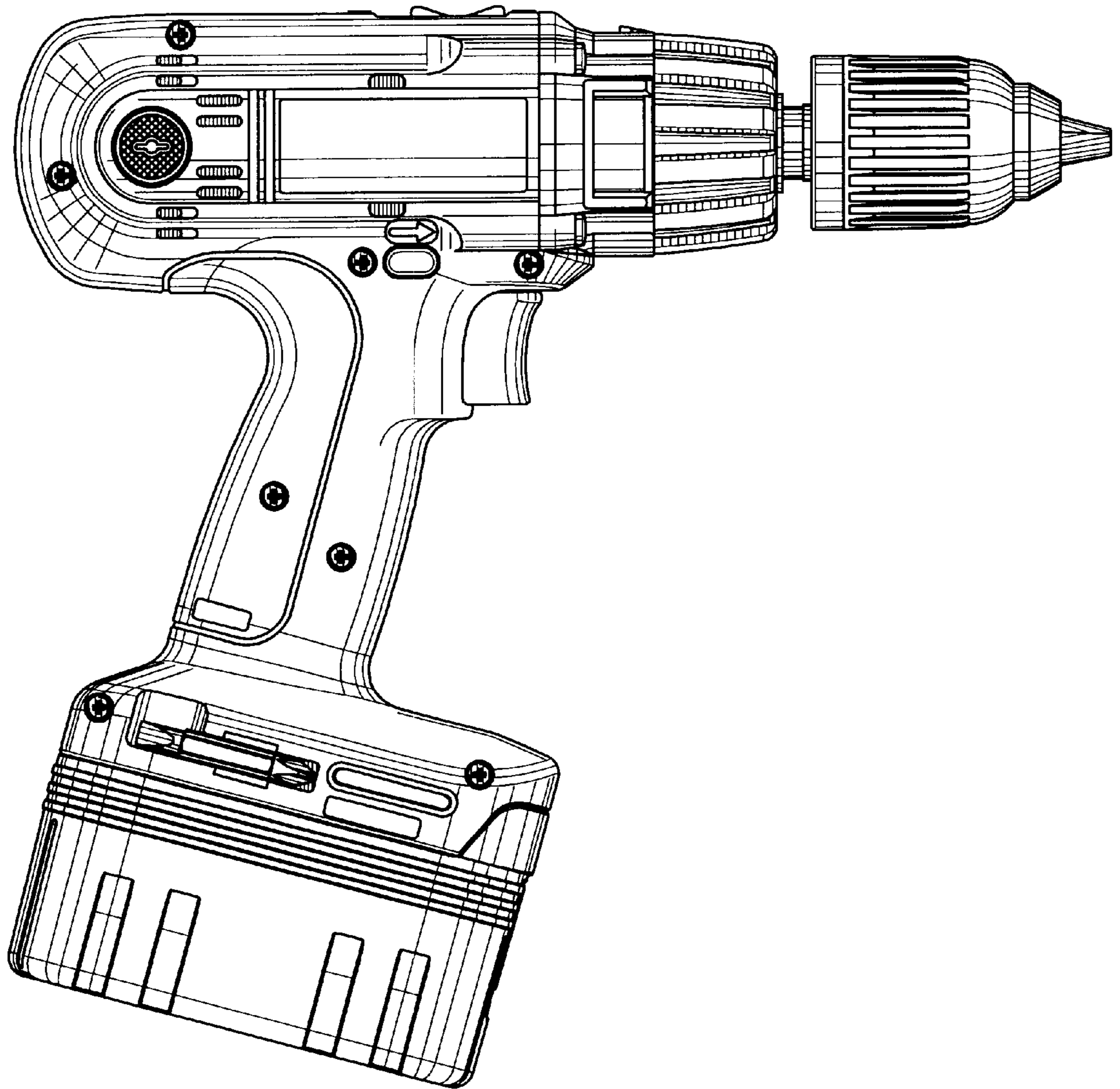

FIG. 3

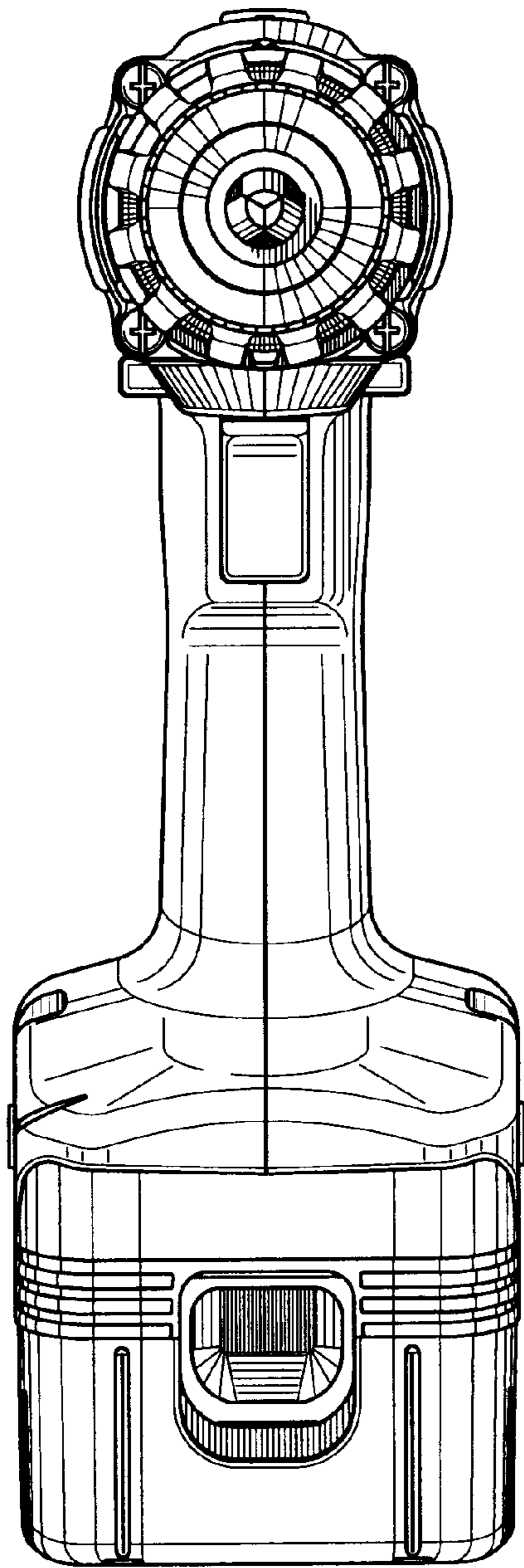

FIG. 4

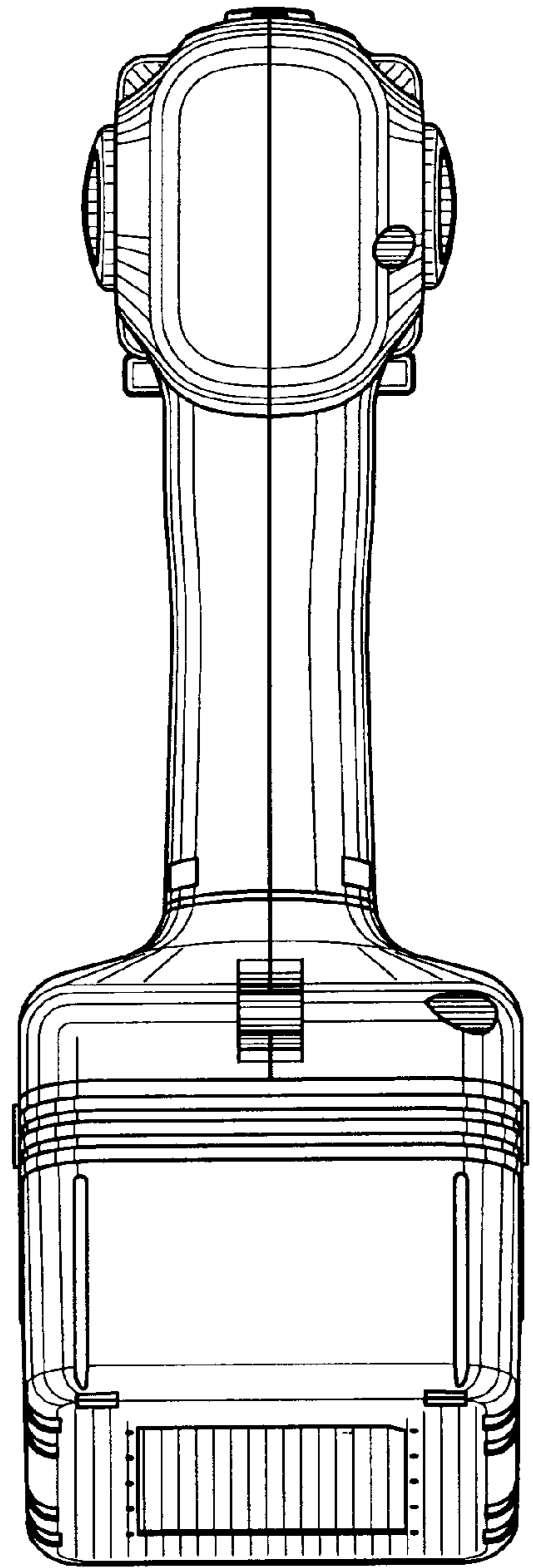

FIG. 5

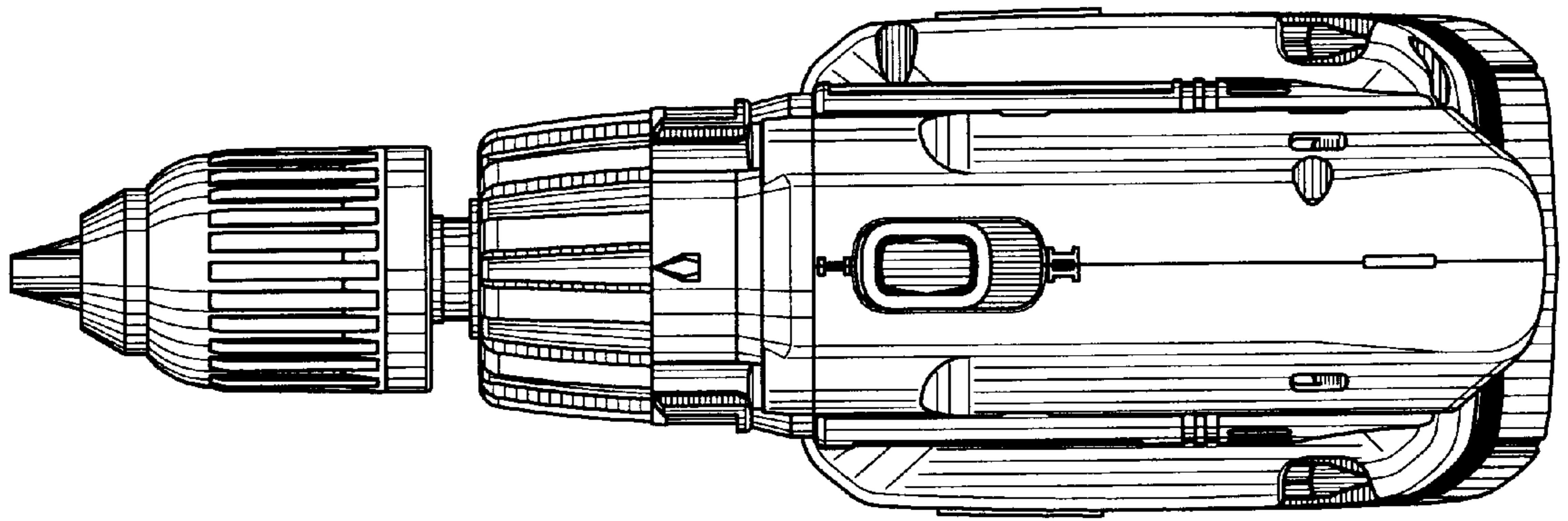

FIG. 6

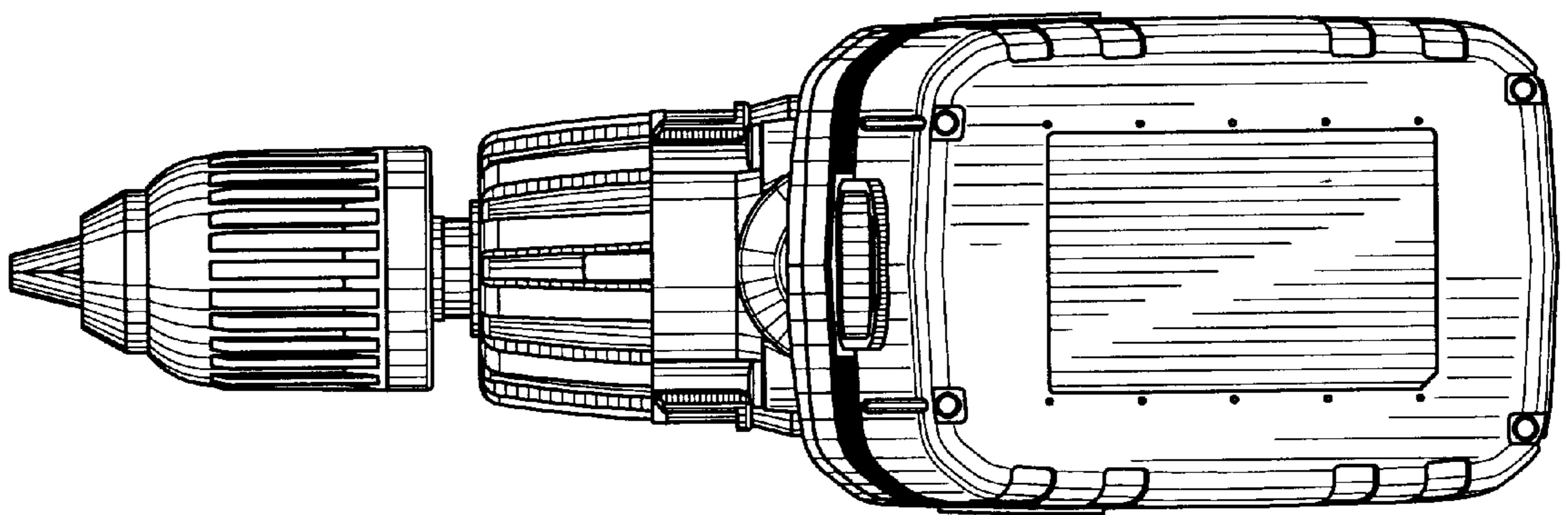

FIG. 7