



US00D436387S

(12) **United States Design Patent**
Pardi

(10) **Patent No.:** **US D436,387 S**

(45) **Date of Patent:** **** Jan. 16, 2001**

(54) **CHILDREN'S RIDE-ON VEHICLE**

(75) Inventor: **Jared Paul Pardi**, East Aurora, NY (US)

(73) Assignee: **Mattel, Inc.**, El Segundo, CA (US)

(**) Term: **14 Years**

(21) Appl. No.: **29/118,428**

(22) Filed: **Feb. 7, 2000**

(51) **LOC (7) Cl.** **21-01**

(52) **U.S. Cl.** **D21/429**

(58) **Field of Search** D21/419-435,
D21/533, 537, 548, 560, 534, 416; D12/108,
112; 446/275, 451, 279, 286, 462, 463,
465, 440; 280/87.021, 87.01, 1.16, 1.13,
282

1,439,394 12/1922 Banks .
1,585,197 5/1926 Marcoux .
1,808,887 6/1931 Dunkley .
2,794,649 6/1957 Arndt et al. .
3,514,117 5/1970 Olsen .
4,546,989 10/1985 Peterson .
5,074,820 12/1991 Nakayama .
5,316,515 5/1994 Hyman et al. .
5,697,621 12/1997 Nazarian .

* cited by examiner

Primary Examiner—Raphael Barkai
(74) *Attorney, Agent, or Firm*—Kolisich, Hartwell, Dickinson, McCormack & Heuser

(57) **CLAIM**

The ornamental design for a children's ride-on vehicle, as shown and described.

DESCRIPTION

FIG. 1 is an isometric view of an embodiment of a children's ride-on vehicle showing the claimed design.

FIG. 2 is a left side elevation view of the vehicle of FIG. 1.

FIG. 3 is a right side elevation view of the vehicle of FIG. 1.

FIG. 4 is a top plan view of the vehicle of FIG. 1.

FIG. 5 is a rear elevation view of the vehicle of FIG. 1.

FIG. 6 is an isometric view of another embodiment of a children's ride-on vehicle showing the claimed design.

FIG. 7 is a left side elevation view of the vehicle of FIG. 6.

FIG. 8 is a right side elevation view of the vehicle of FIG. 6.

FIG. 9 is a top plan view of the vehicle of FIG. 6; and, FIG. 10 is a rear elevation view of the vehicle of FIG. 6. The bottom of the vehicle forms no part of the claimed design.

(56) **References Cited**

U.S. PATENT DOCUMENTS

D. 82,294 * 10/1930 Wetzell D21/429
91,398 6/1869 Wirtz .
101,310 3/1870 Purroy .
D. 150,468 * 8/1948 Sebel D21/429
D. 164,454 * 9/1951 Sebel D21/429
184,435 11/1876 Slemmer .
199,518 1/1878 Crandall .
209,777 11/1878 Ross .
D. 326,485 * 5/1992 Rudell et al. D21/429
495,531 4/1893 Thorp .
632,278 9/1899 Plass .
787,670 4/1905 Hyde .
808,616 12/1905 Thompson .
908,229 12/1908 Fahrney .
970,849 9/1910 Pettit et al. .
990,997 * 5/1911 Magee 280/1.16

1 Claim, 10 Drawing Sheets

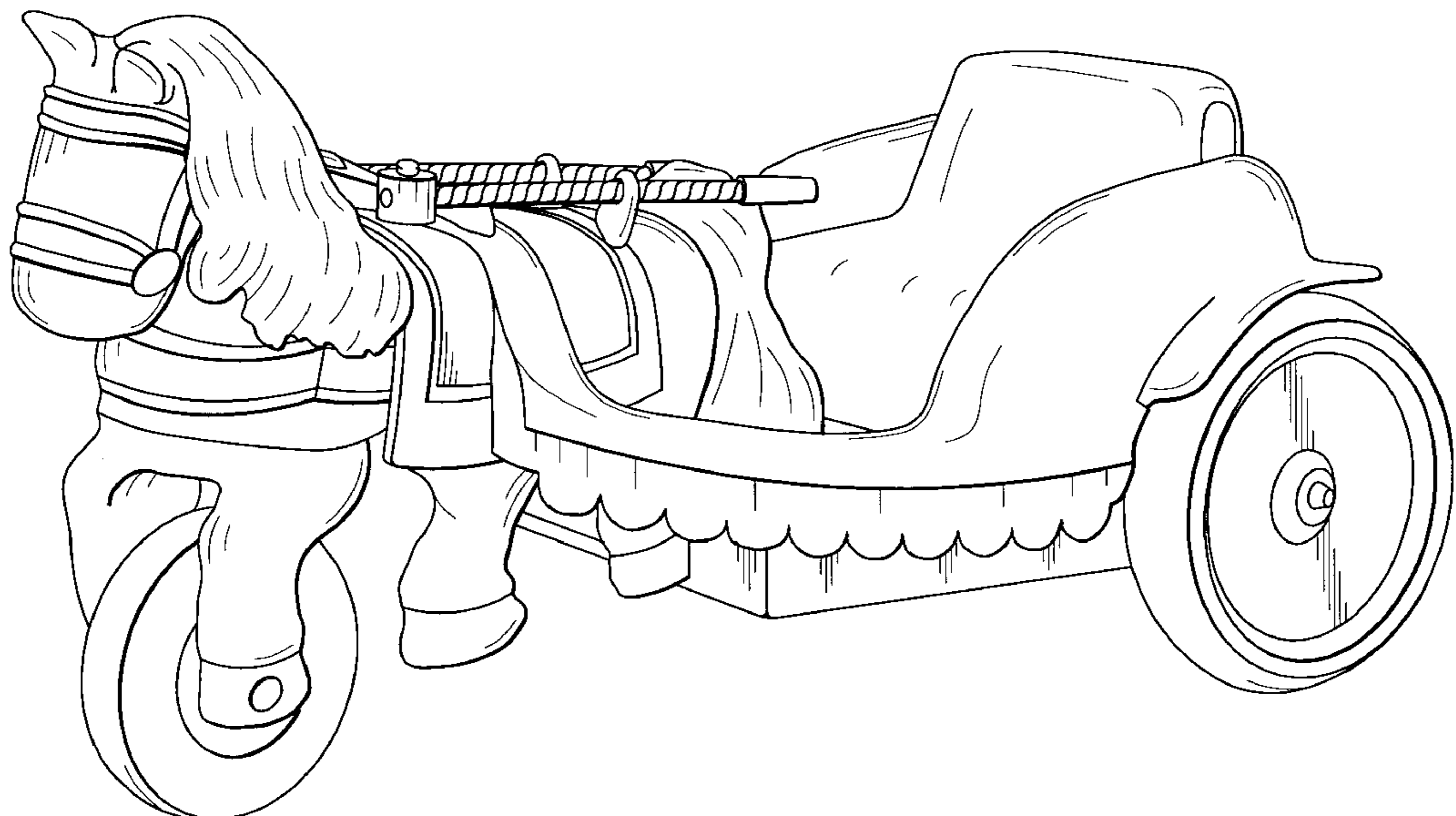

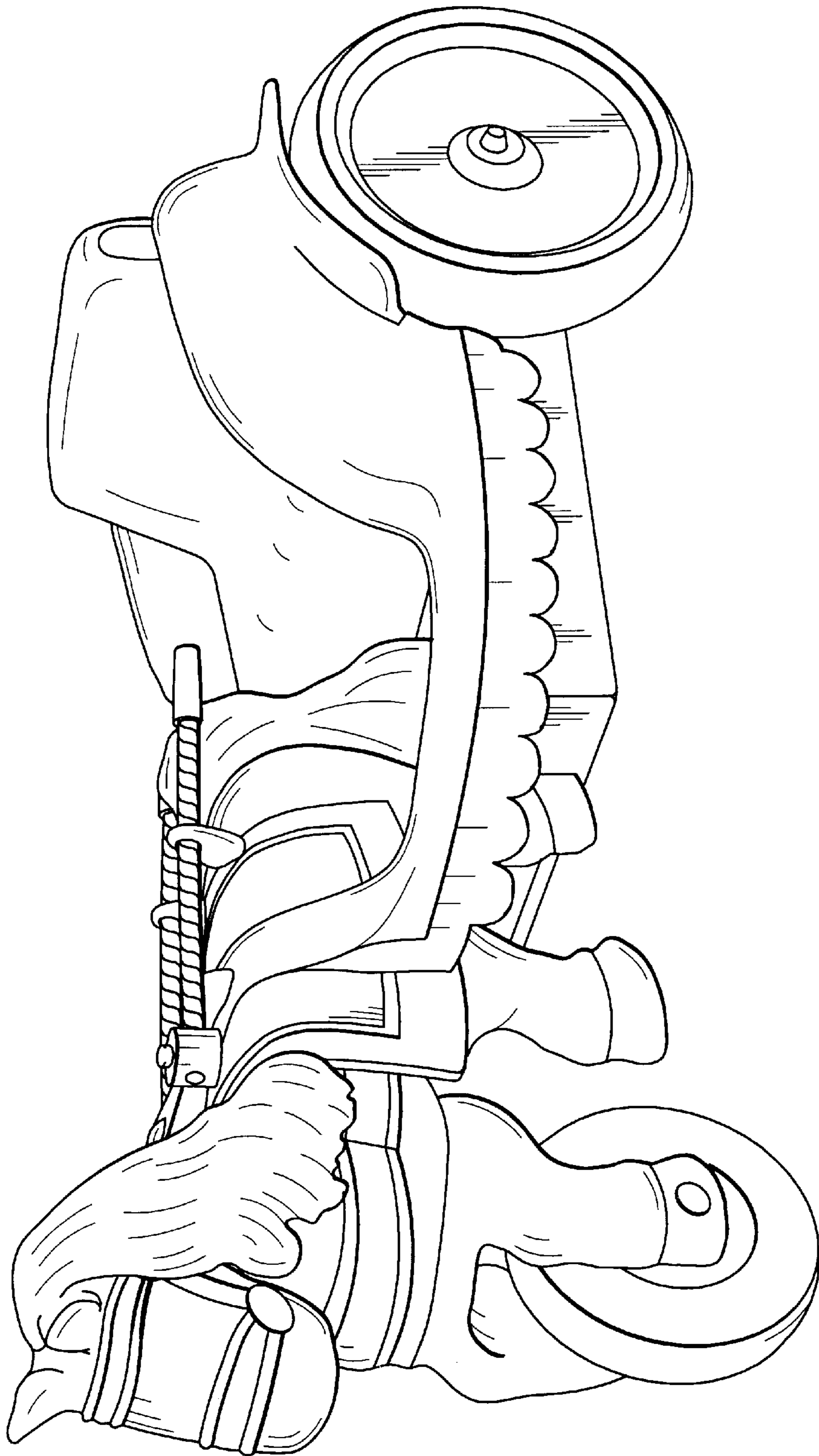

FIG. 1

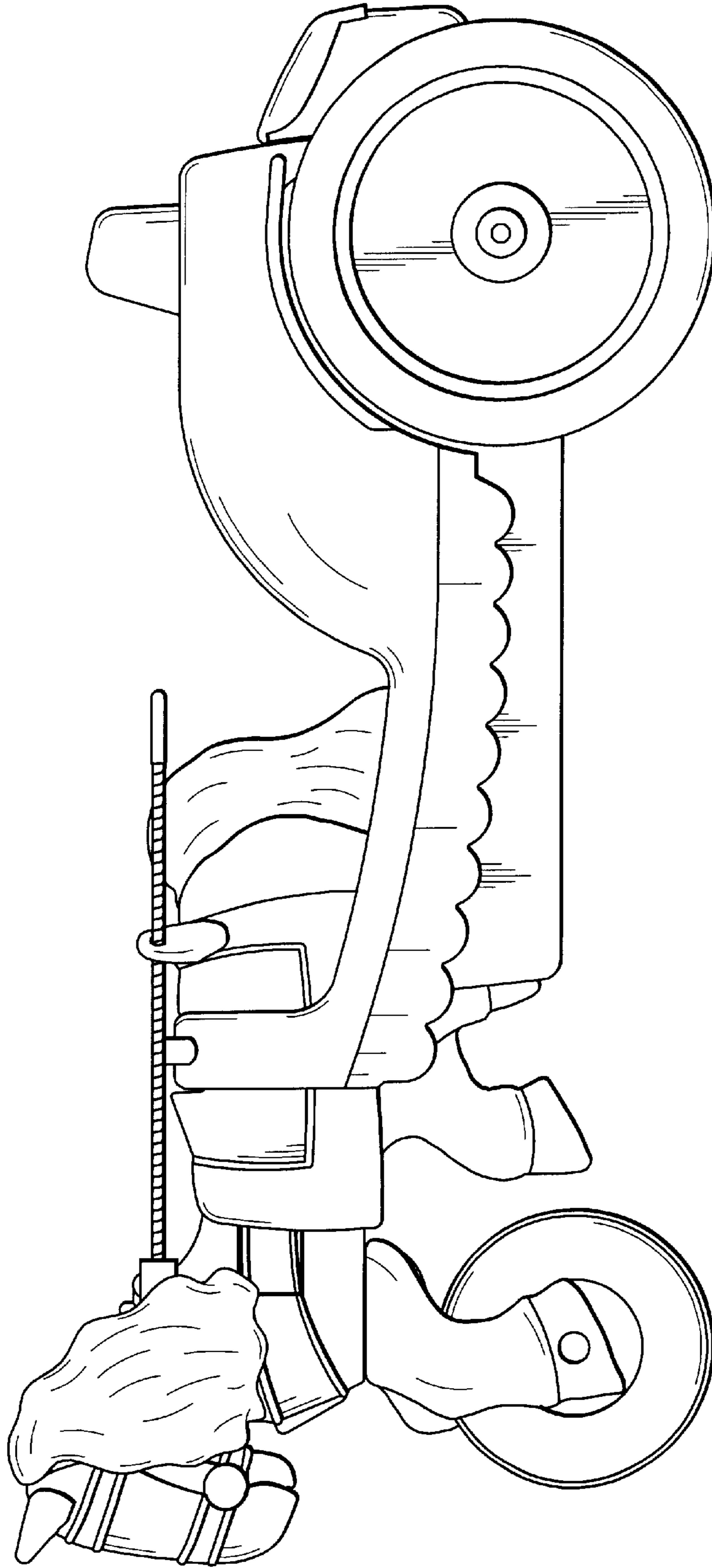

FIG. 2

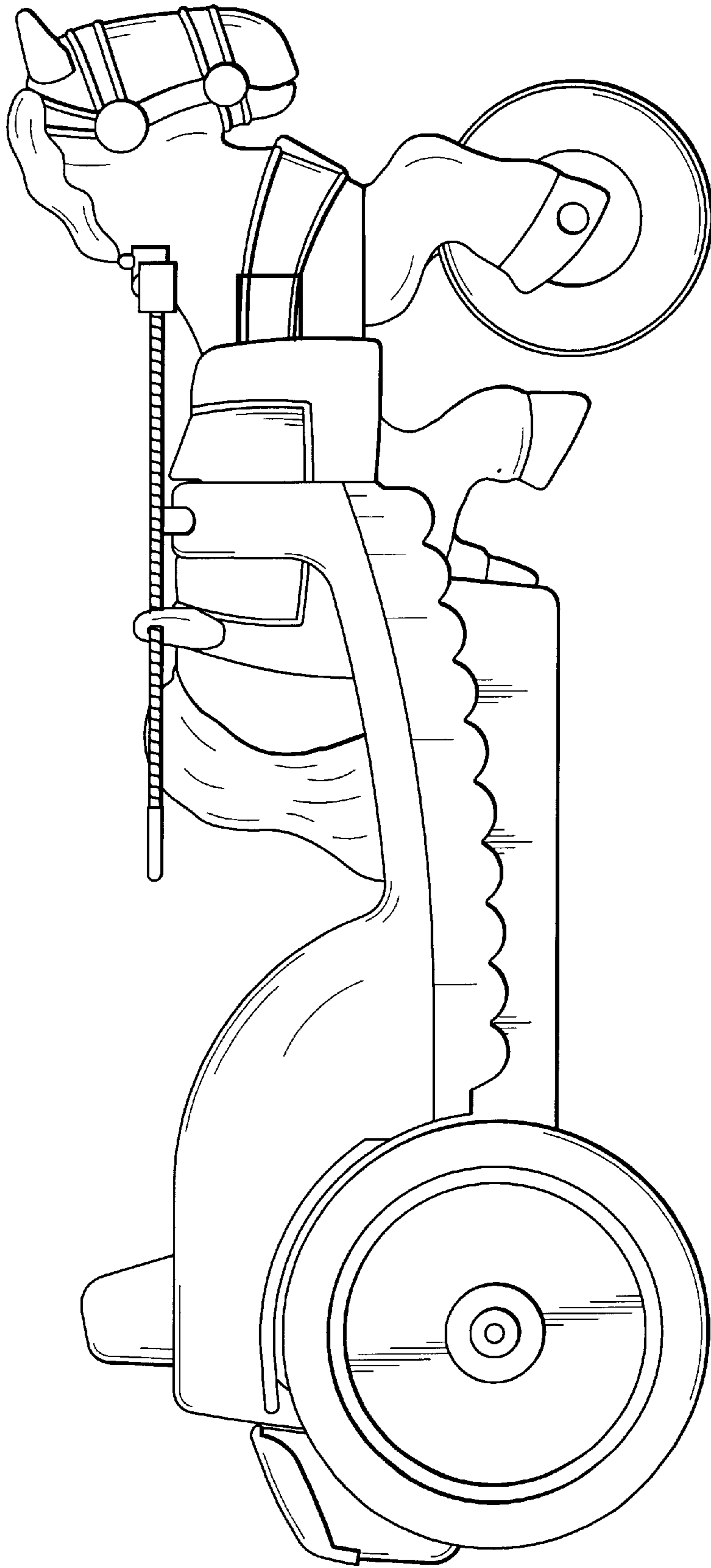

FIG. 3

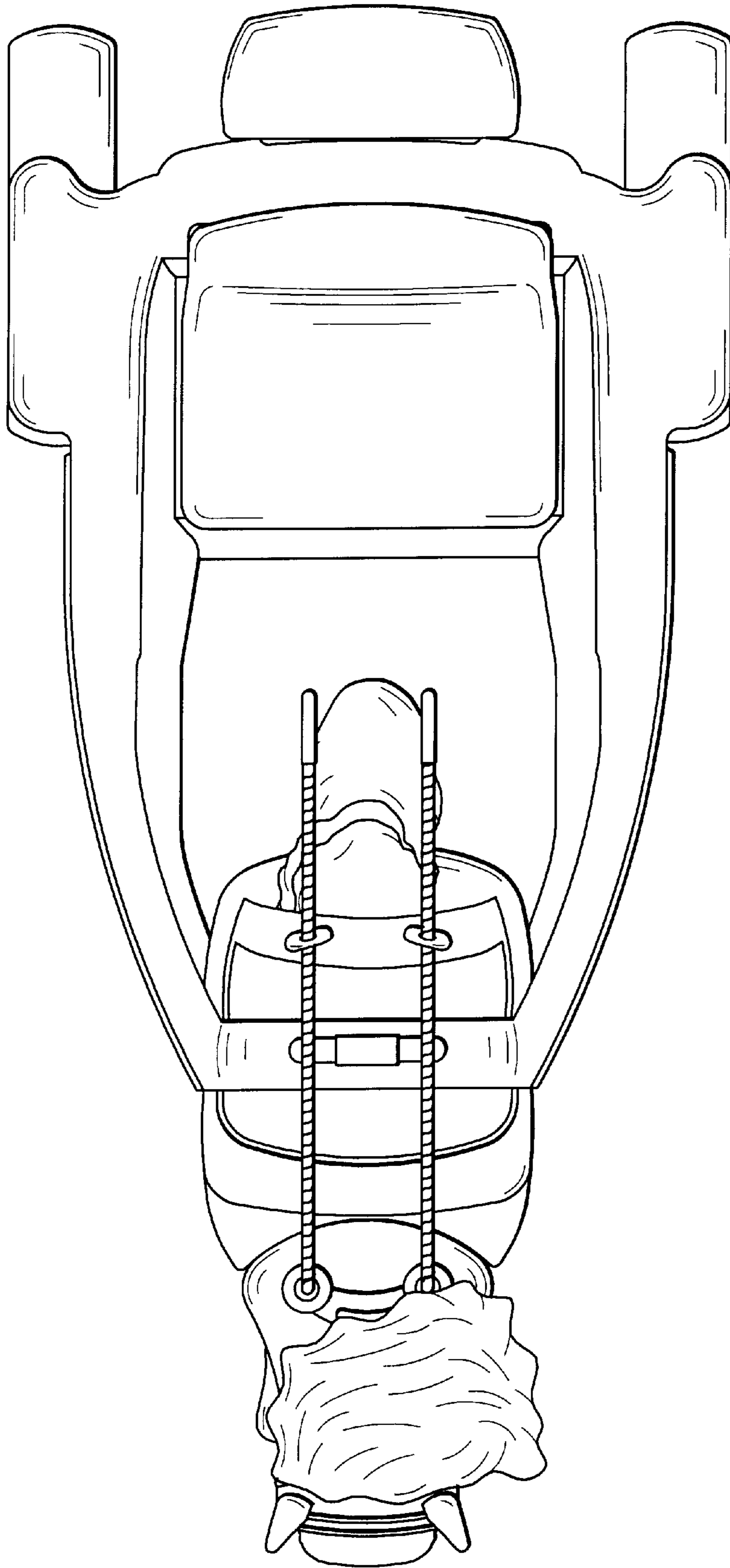

FIG. 4

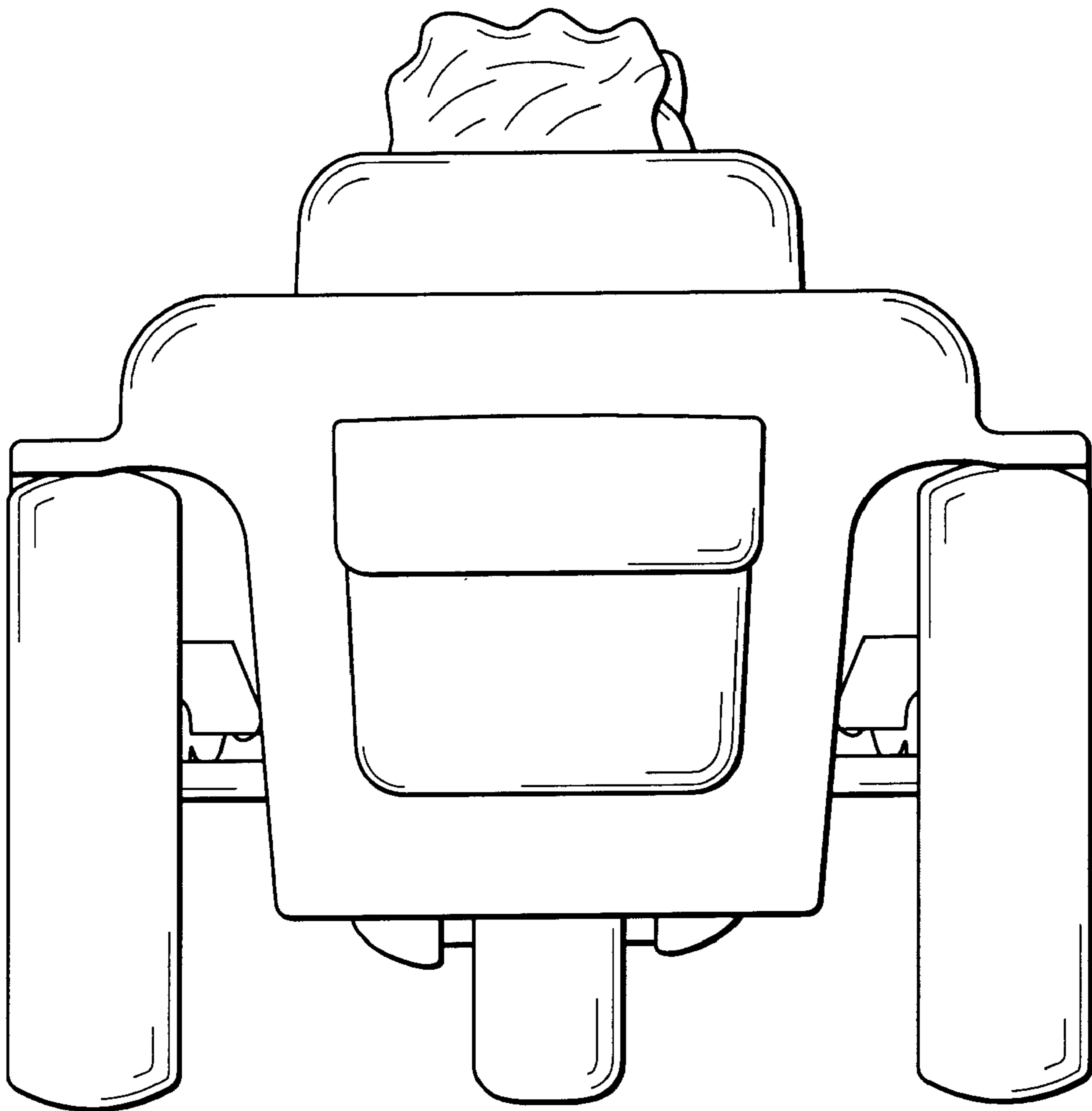

FIG. 5

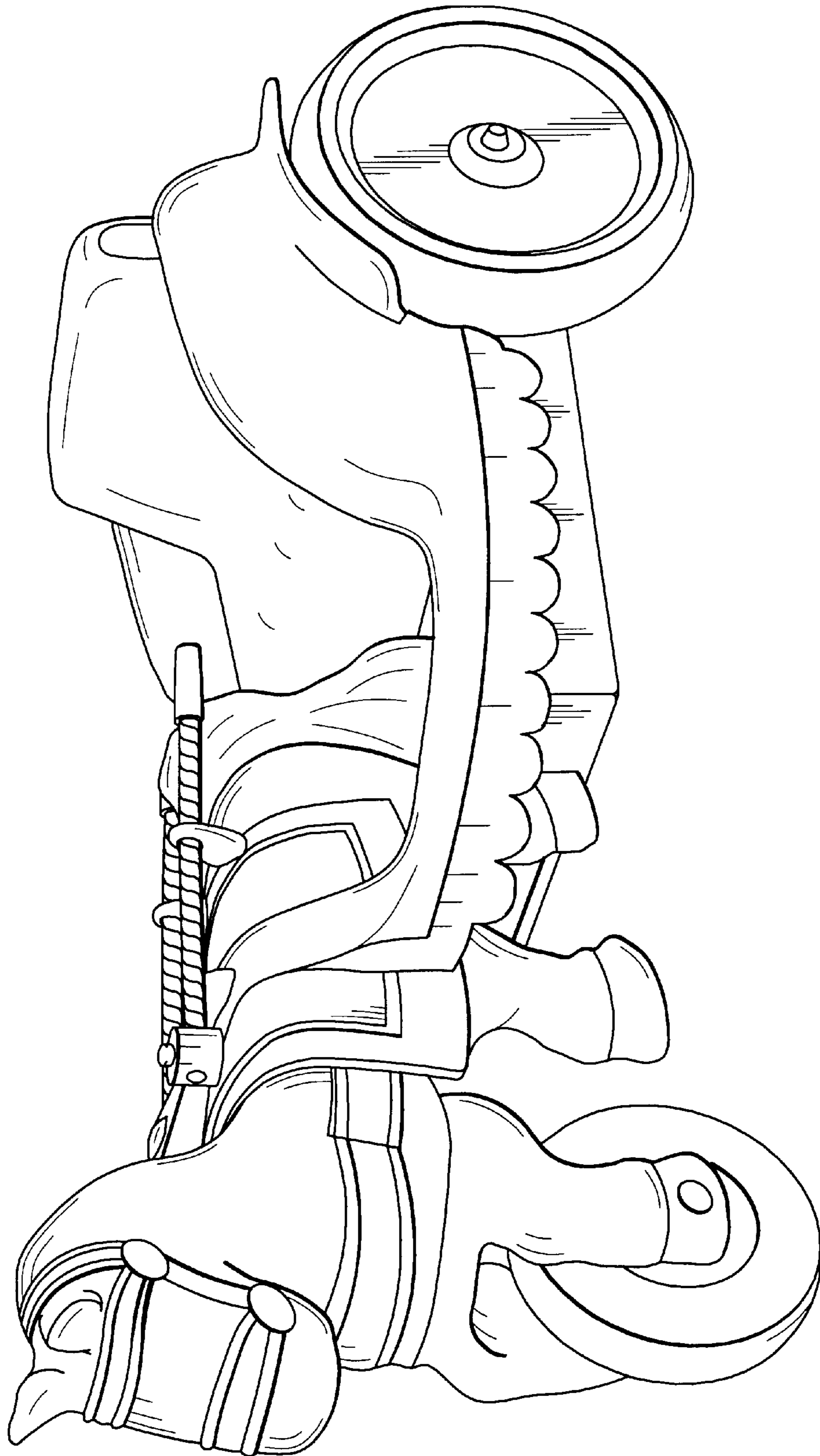

FIG. 6

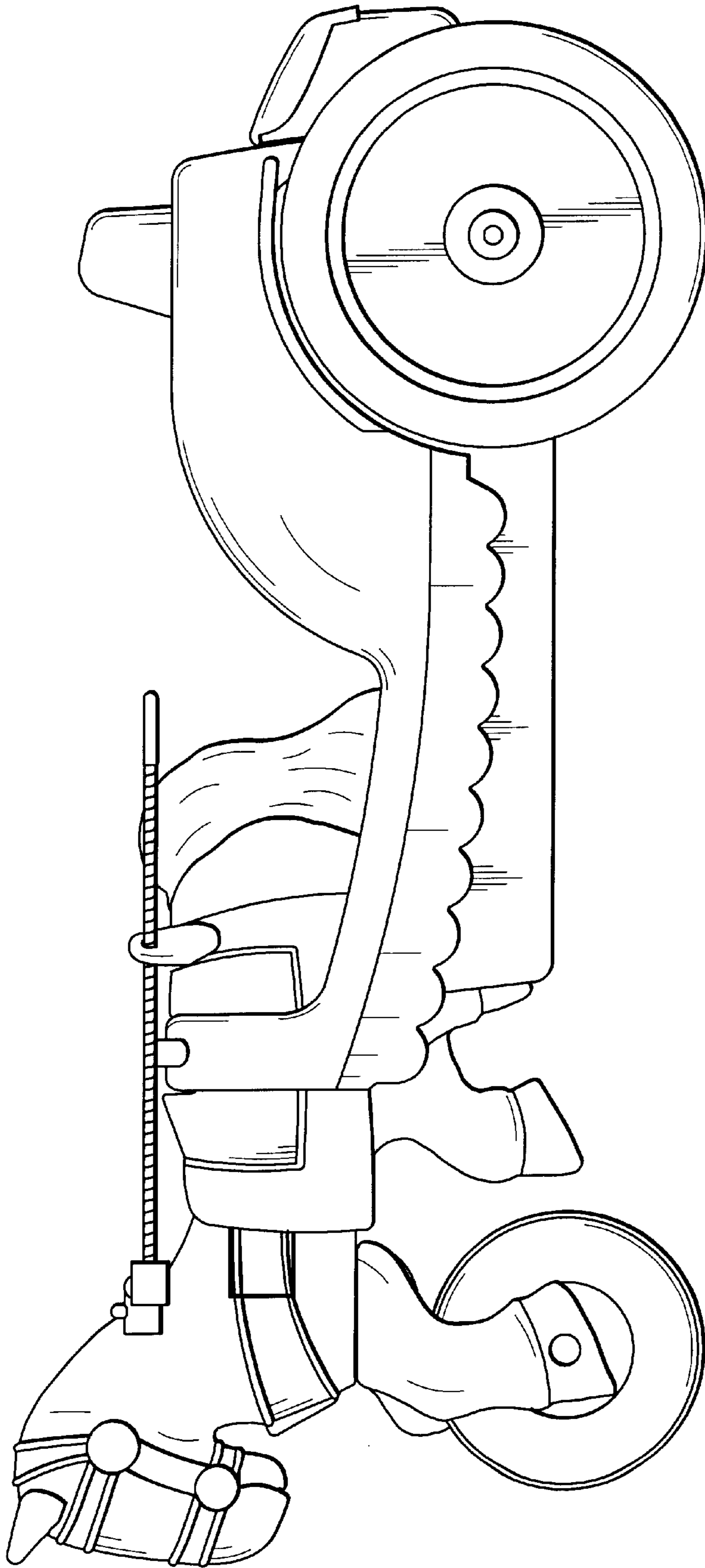

FIG. 7

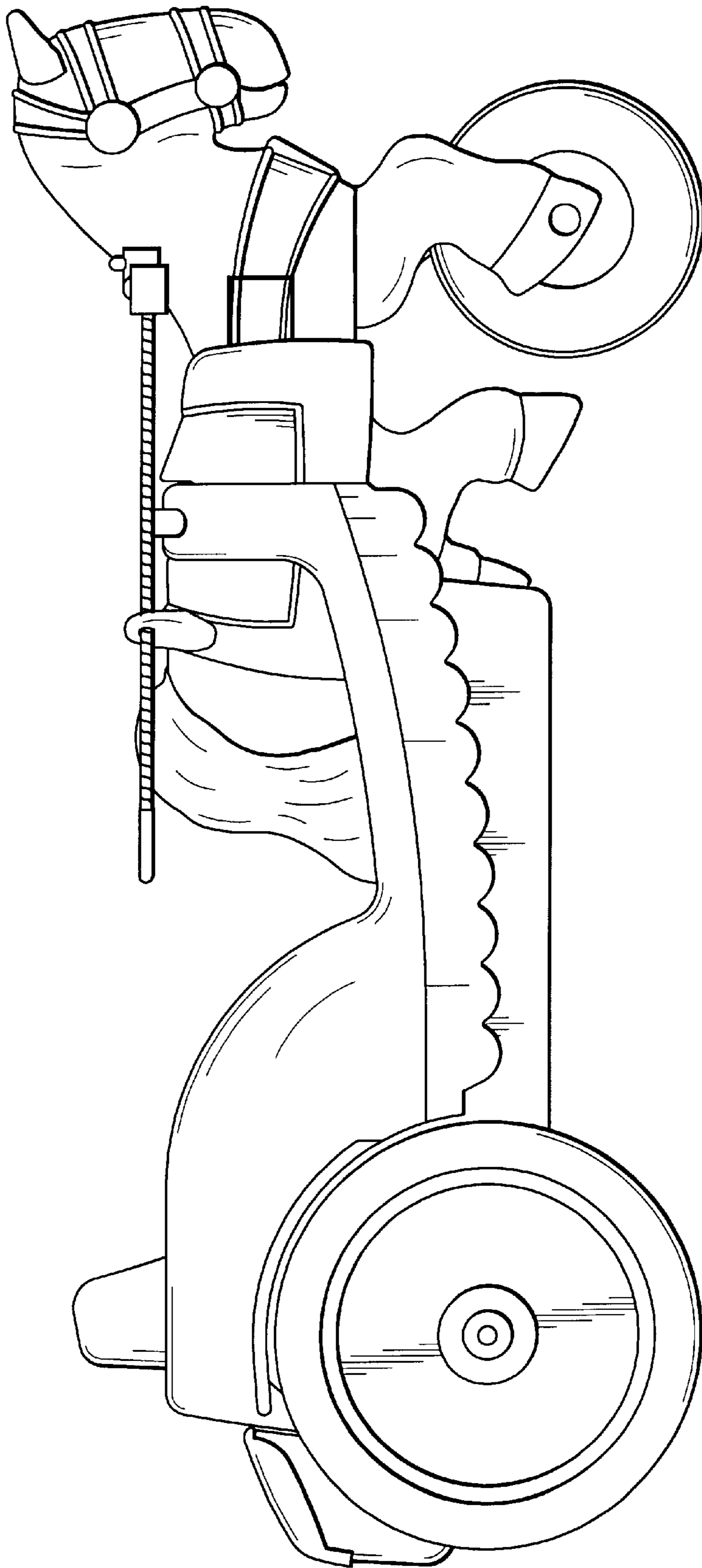

FIG. 8

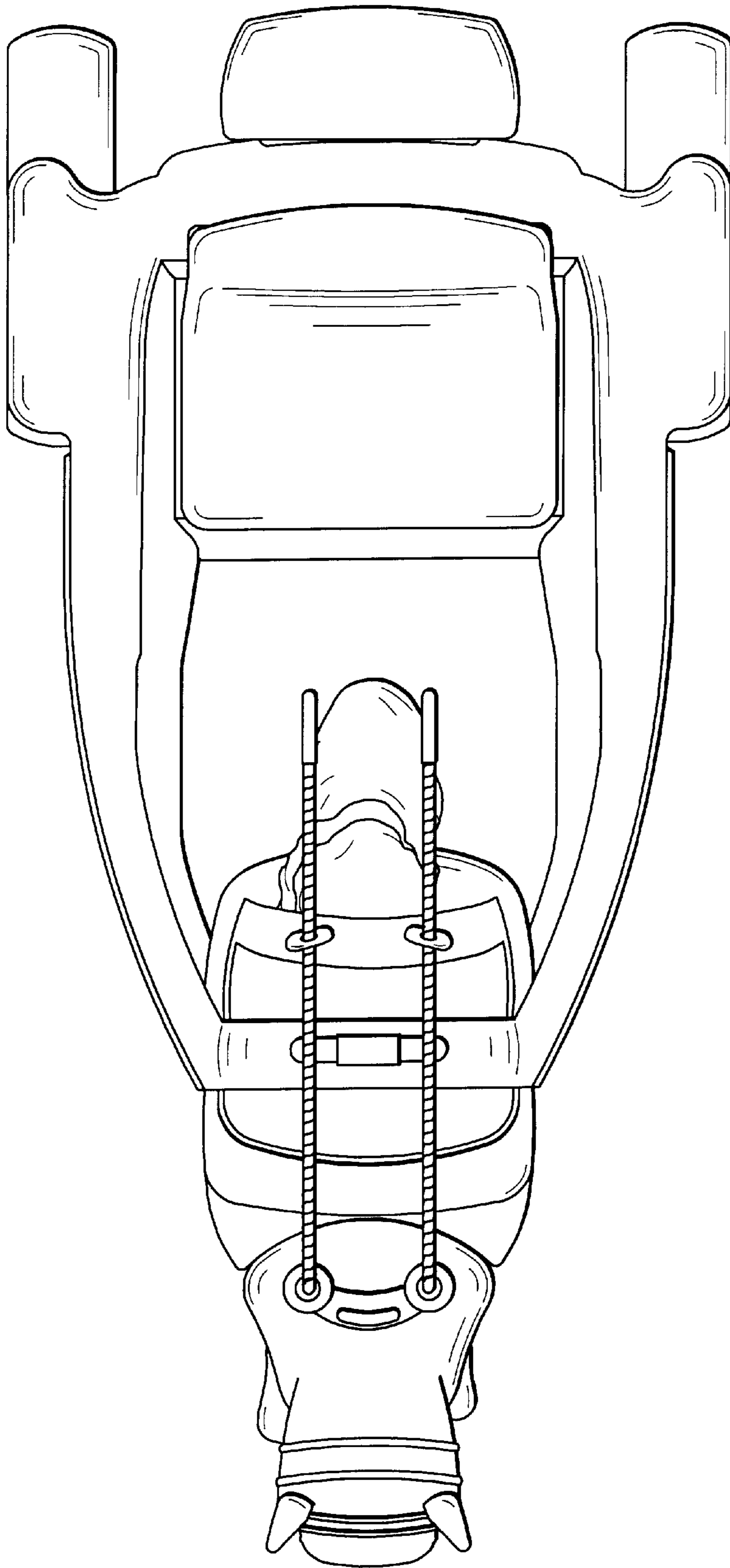

FIG. 9

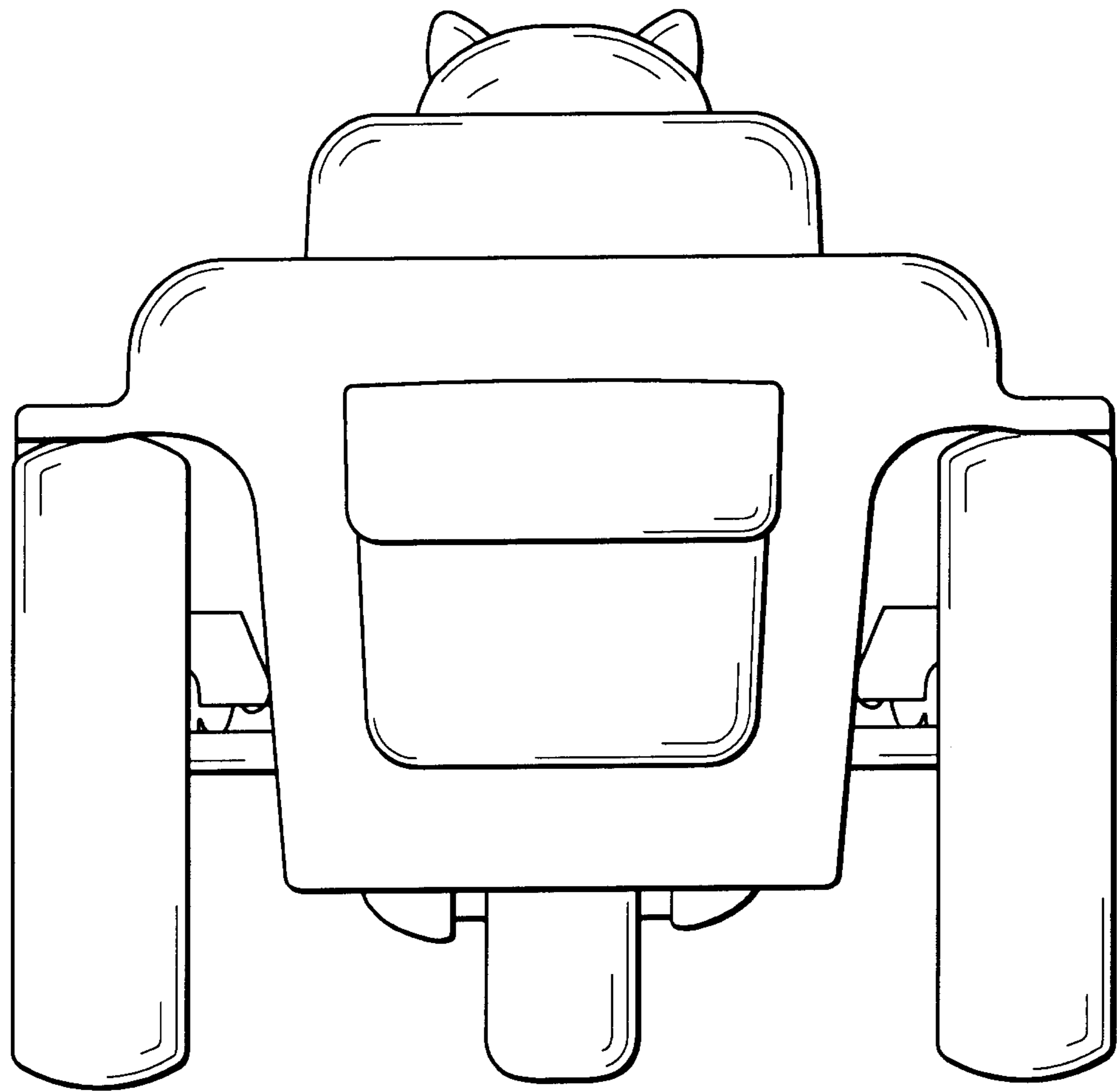

FIG. 10