



US00D436342S

(12) **United States Design Patent**
Lopez

(10) **Patent No.:** **US D436,342 S**

(45) **Date of Patent:** **** Jan. 16, 2001**

(54) **VEHICLE CARGO ORGANIZER**

4,085,987 * 4/1978 Vartdal 312/269

(76) Inventor: **Paula Lopez**, 1525 E. 26th St.,
Brooklyn, NY (US) 11229

* cited by examiner

(**) Term: **14 Years**

Primary Examiner—Doris V. Coles

Assistant Examiner—Stacia Sinuik

(21) Appl. No.: **29/108,623**

(57) **CLAIM**

(22) Filed: **Jul. 30, 1999**

The ornamental design for a vehicle cargo organizer, as shown and described.

(51) **LOC (7) Cl.** **12-99**

DESCRIPTION

(52) **U.S. Cl.** **D12/414.1**

(58) **Field of Search** D12/412-414.1,
D12/423-425; D3/315, 905, 273; D8/71;
D9/341; 296/24.1, 37.1-37.6; 224/539-541,
400, 403-404; 280/901

FIG. 1 is a top, front, right side perspective view of an opened vehicle cargo organizer of the present invention; FIG. 2 is a left side elevational view of the vehicle cargo organizer of FIG. 1 shown in closed position; FIG. 3 is a front elevational view of the vehicle cargo organizer of FIG. 1 shown in closed position; FIG. 4 is a back elevational view of the vehicle cargo organizer of FIG. 1 shown in closed position; FIG. 5 is a top plan view of the vehicle cargo organizer of FIG. 1 shown in closed position; and, FIG. 6 is a bottom plan view of the vehicle cargo organizer of FIG. 1 shown in closed position.

(56) **References Cited**

U.S. PATENT DOCUMENTS

- D. 237,121 * 10/1975 Metzner D3/905
- D. 325,672 * 4/1992 Baker D3/905
- D. 329,999 * 10/1992 Vourakes et al. D12/414.1
- D. 335,029 * 4/1993 Gerding D3/905
- D. 358,125 * 5/1995 Jackson D12/425
- D. 372,016 * 7/1996 Wolford D12/423
- D. 373,988 * 9/1996 Johnson D12/423
- D. 411,164 * 6/1999 Harris D12/414.1

The right side elevational view is a mirror image of the left side as shown in FIG. 2.

1 Claim, 2 Drawing Sheets

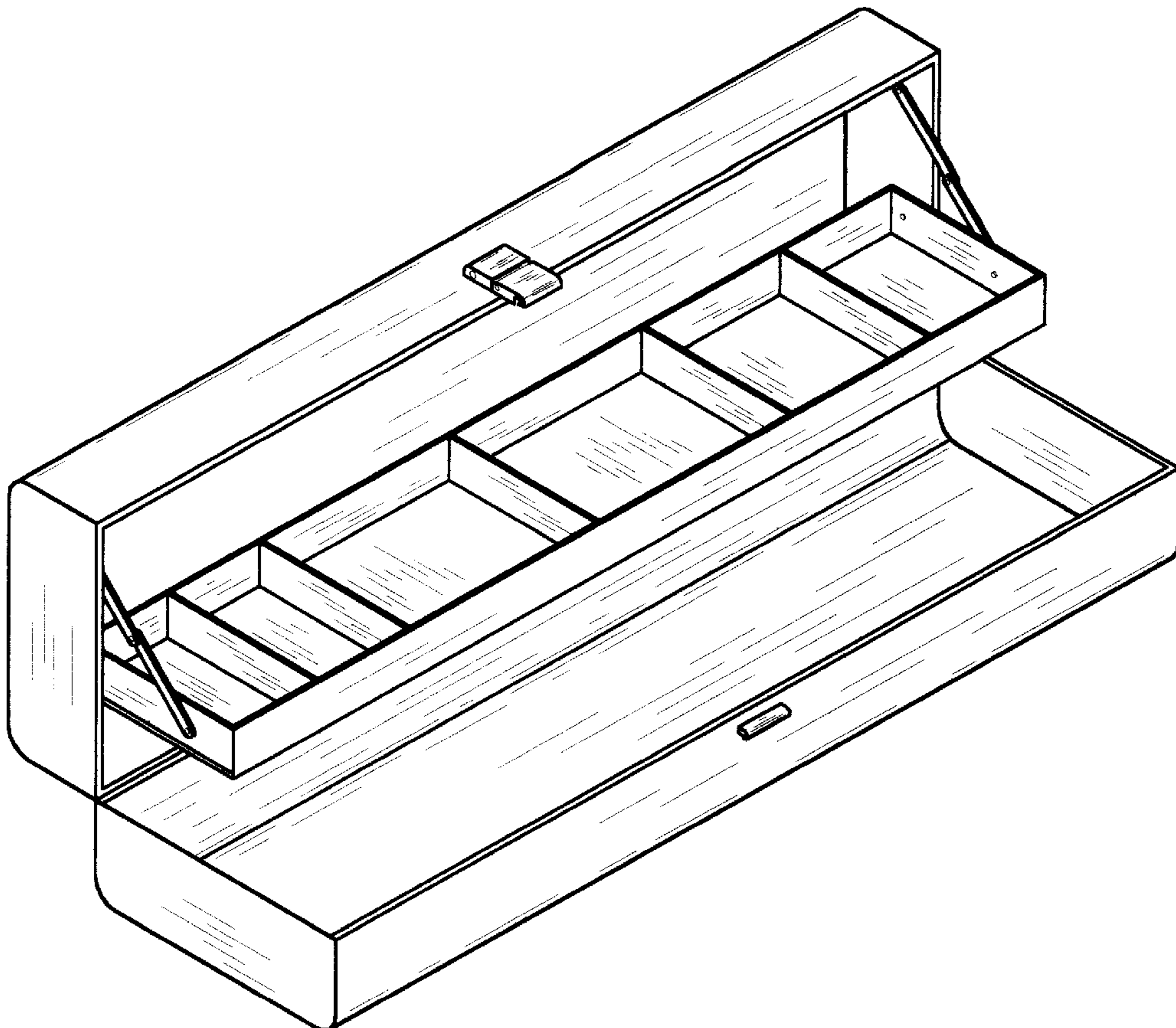

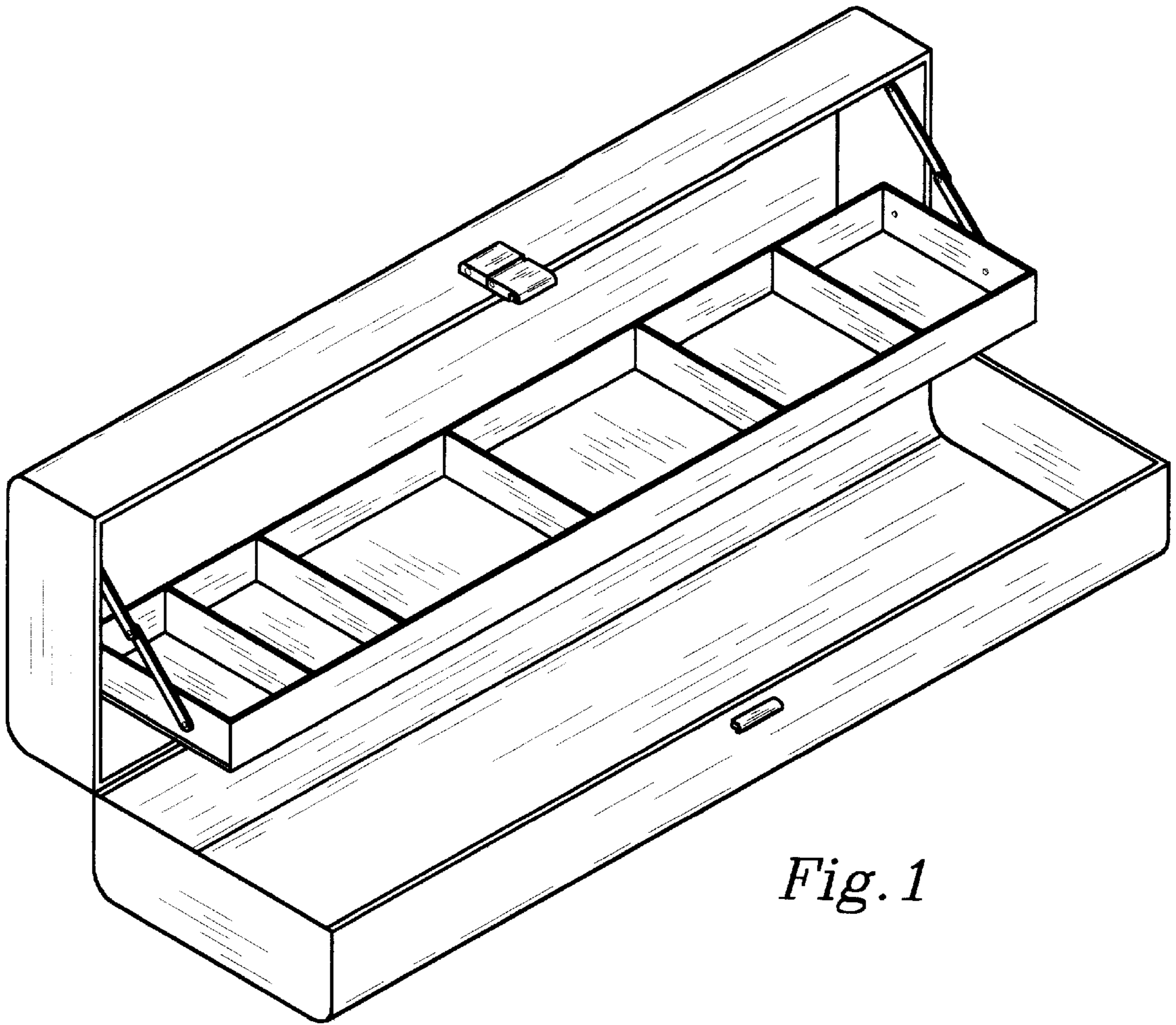

Fig. 1

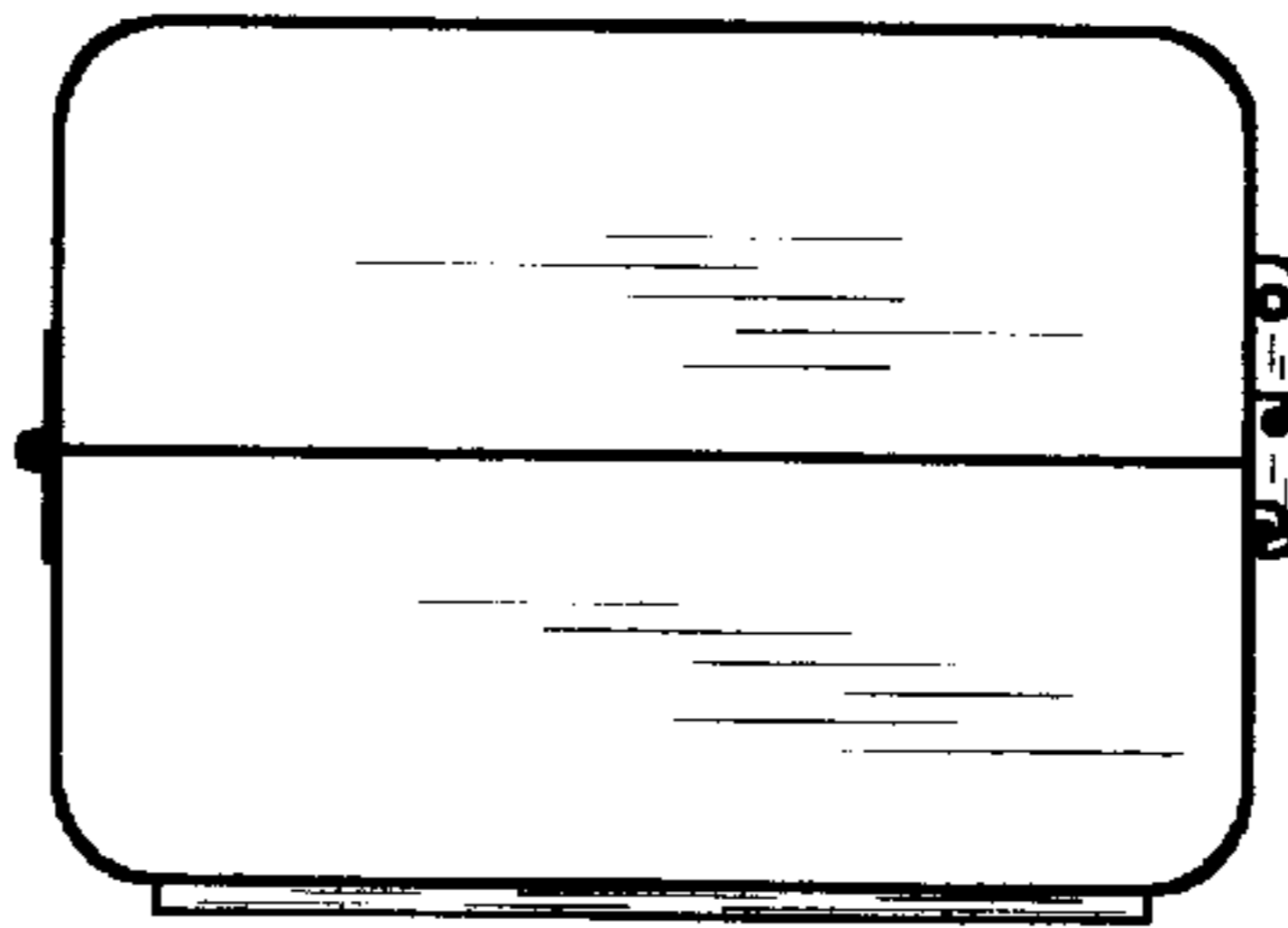

Fig. 2

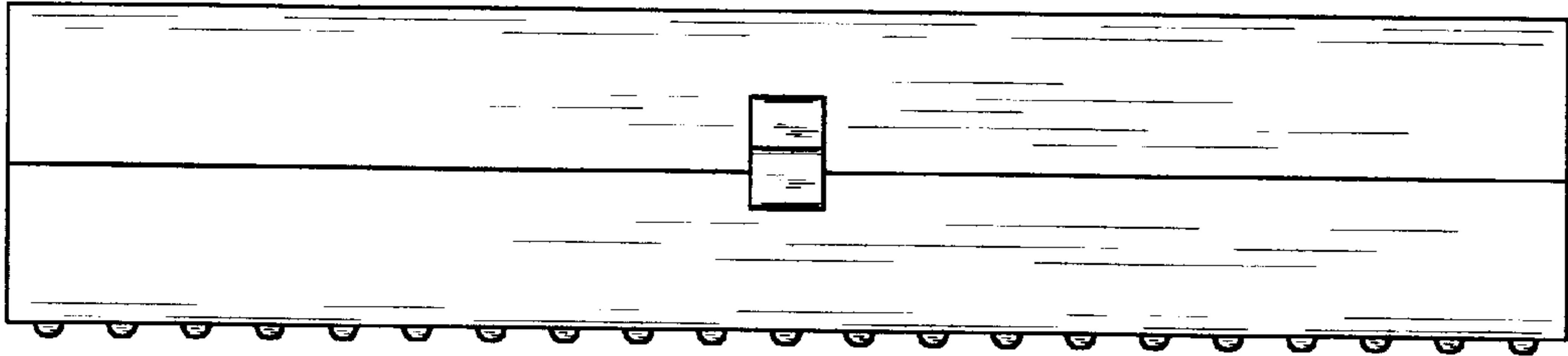

Fig. 3

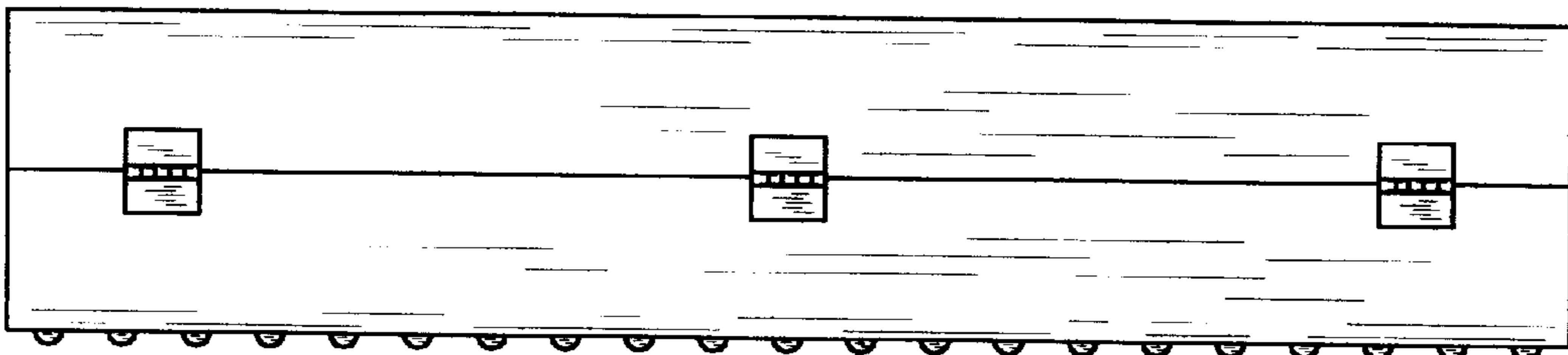

Fig. 4

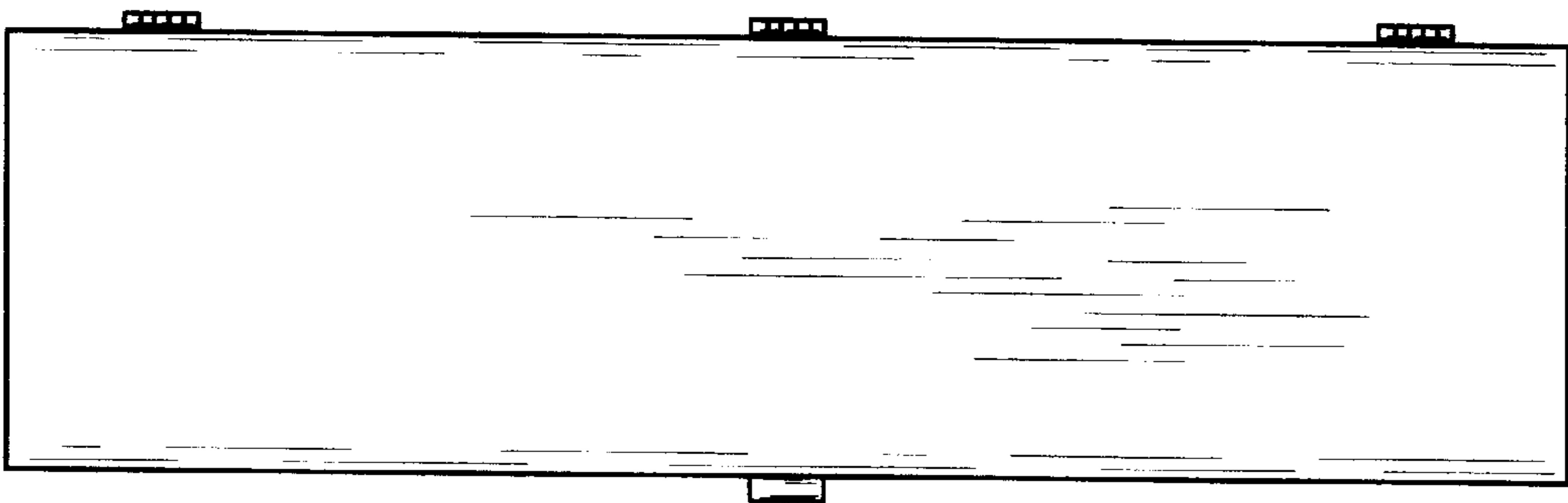

Fig. 5

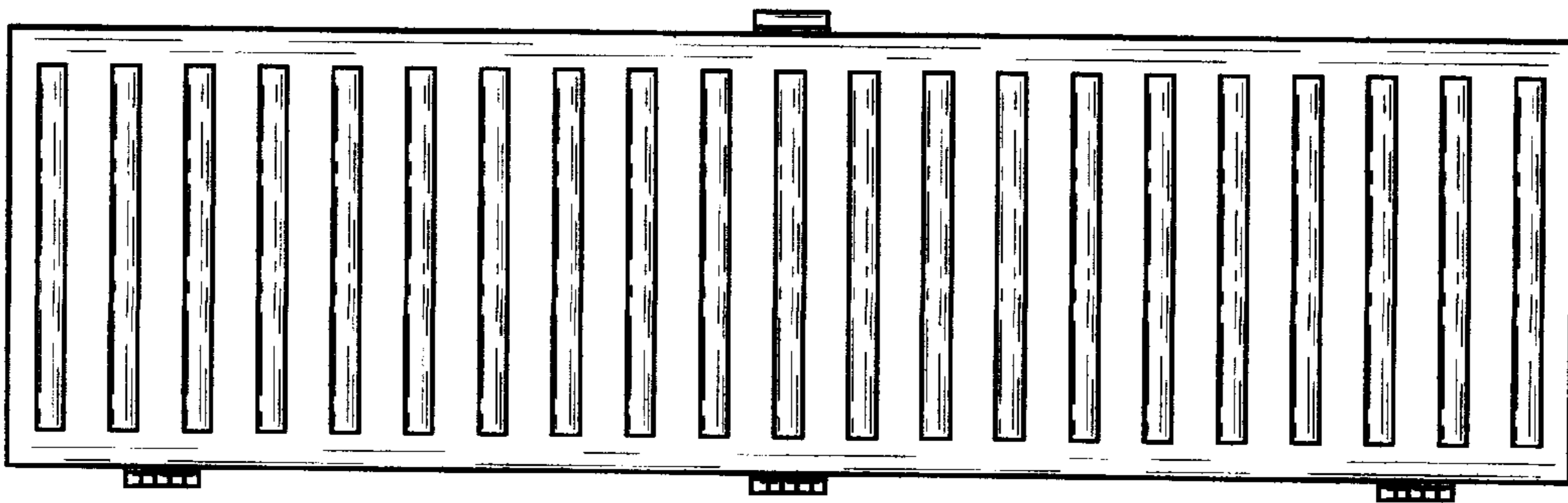

Fig. 6