



US00D436114S

(12) **United States Design Patent**
Beugelsdyk et al.

(10) **Patent No.:** **US D436,114 S**

(45) **Date of Patent:** **** Jan. 9, 2001**

(54) **DUAL ACTION BAIL AND LEVER
LAWNMOWER CABLE CONTROL
ASSEMBLY**

(75) **Inventors:** **Anthony F. Beugelsdyk; Michael A. Barnard**, both of Wichita, KS (US)

(73) **Assignee:** **Wescon Products Company**, Wichita, KS (US)

(**) **Term:** **14 Years**

(21) **Appl. No.:** **29/094,826**

(22) **Filed:** **Oct. 12, 1998**

(51) **LOC (7) Cl.** **15-03**

(52) **U.S. Cl.** **D15/17**

(58) **Field of Search** D12/179; D15/14-18,
D15/28; 56/10.5, 10.8; 74/501.6, 502.3,
523

(56) **References Cited**

U.S. PATENT DOCUMENTS

D. 344,090	2/1994	Barnard	D15/17
4,428,180	* 1/1984	Carlson	56/11.3
4,936,160	* 6/1990	Barnard et al.	74/501.6

* cited by examiner

Primary Examiner—Sandra L. Morris

(74) *Attorney, Agent, or Firm*—Hovey, Williams, Timmons & Collins

(57) **CLAIM**

The ornamental design for a dual action bail and lever lawnmower cable control assembly, as shown and described.

DESCRIPTION

FIG. 1 is a right side elevational view of a first embodiment of a dual action bail and lever lawnmower cable control assembly showing our new design with the pivotally carried shift handle shown in the upright position; FIG. 2 is a front elevational view thereof; FIG. 3 is a rear elevational view thereof; FIG. 4 is a left side elevational view thereof; FIG. 5 is a bottom plan view thereof; FIG. 6 is a top plan view thereof; FIG. 7 is a left side elevational view of a second embodiment of a dual action bail and lever lawnmower cable control assembly showing our new design with the pivotally carried shift handle shown in the upright position; FIG. 8 is a rear elevational view thereof; FIG. 9 is a front elevational view thereof; FIG. 10 is a right side elevational view thereof; FIG. 11 is a top plan view thereof; FIG. 12 is a bottom plan view thereof; FIG. 13 is a right side elevational view of a third embodiment of a dual action bail and lever lawnmower cable control assembly showing our new design with the pivotally carried shift handle shown in the upright position; FIG. 14 is a front elevational view thereof; FIG. 15 is a rear elevational view thereof; FIG. 16 is a left side elevational view thereof; FIG. 17 is a top plan view thereof; FIG. 18 is a bottom plan view thereof; FIG. 19 is a left side perspective view of the first embodiment of the dual action bail and lever lawnmower cable control assembly hereof; FIG. 20 is a left side perspective view of the second embodiment of the dual action bail and lever lawnmower cable control assembly hereof; and, FIG. 21 is a left side perspective view of the third embodiment of the dual action bail and lever lawnmower cable control assembly hereof.

1 Claim, 4 Drawing Sheets

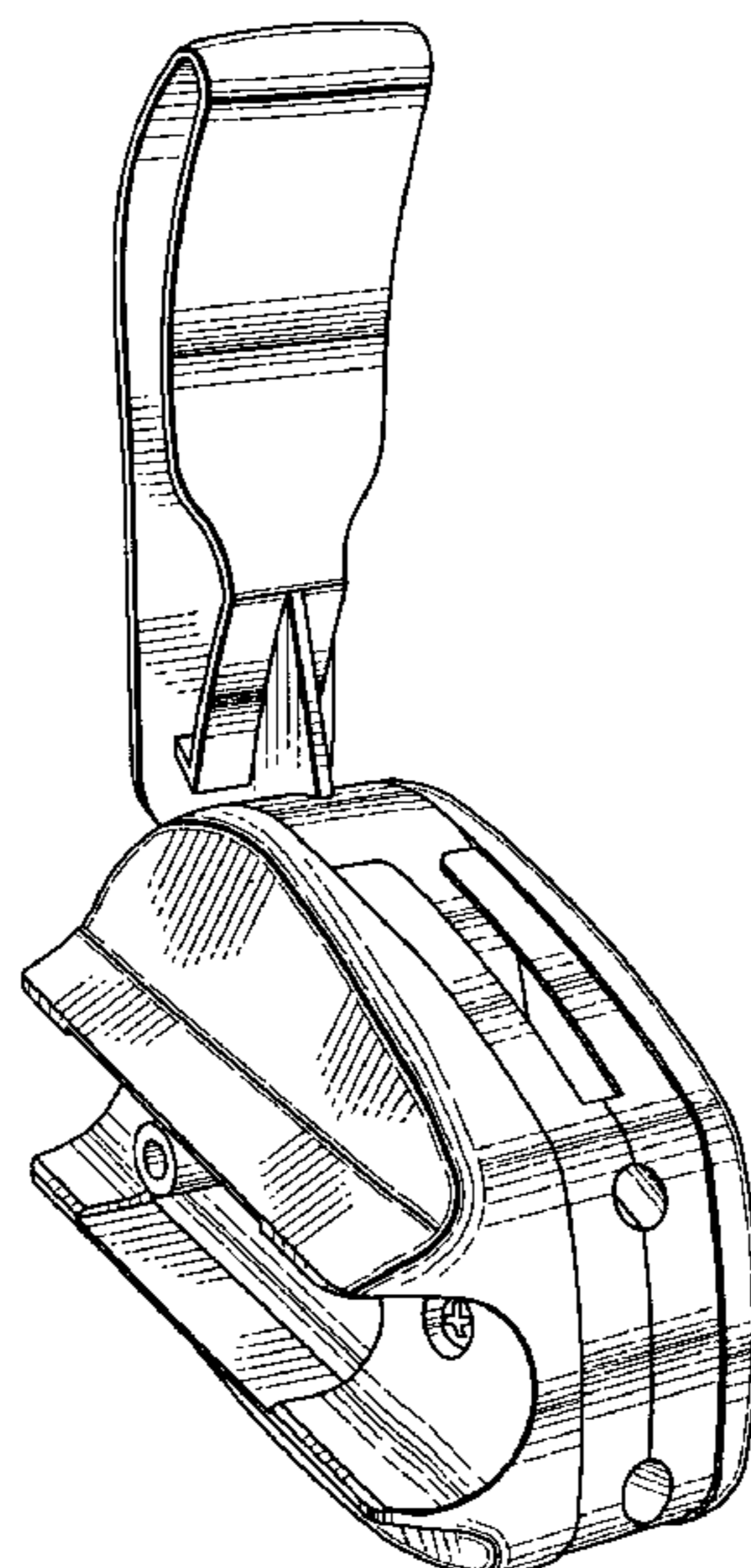

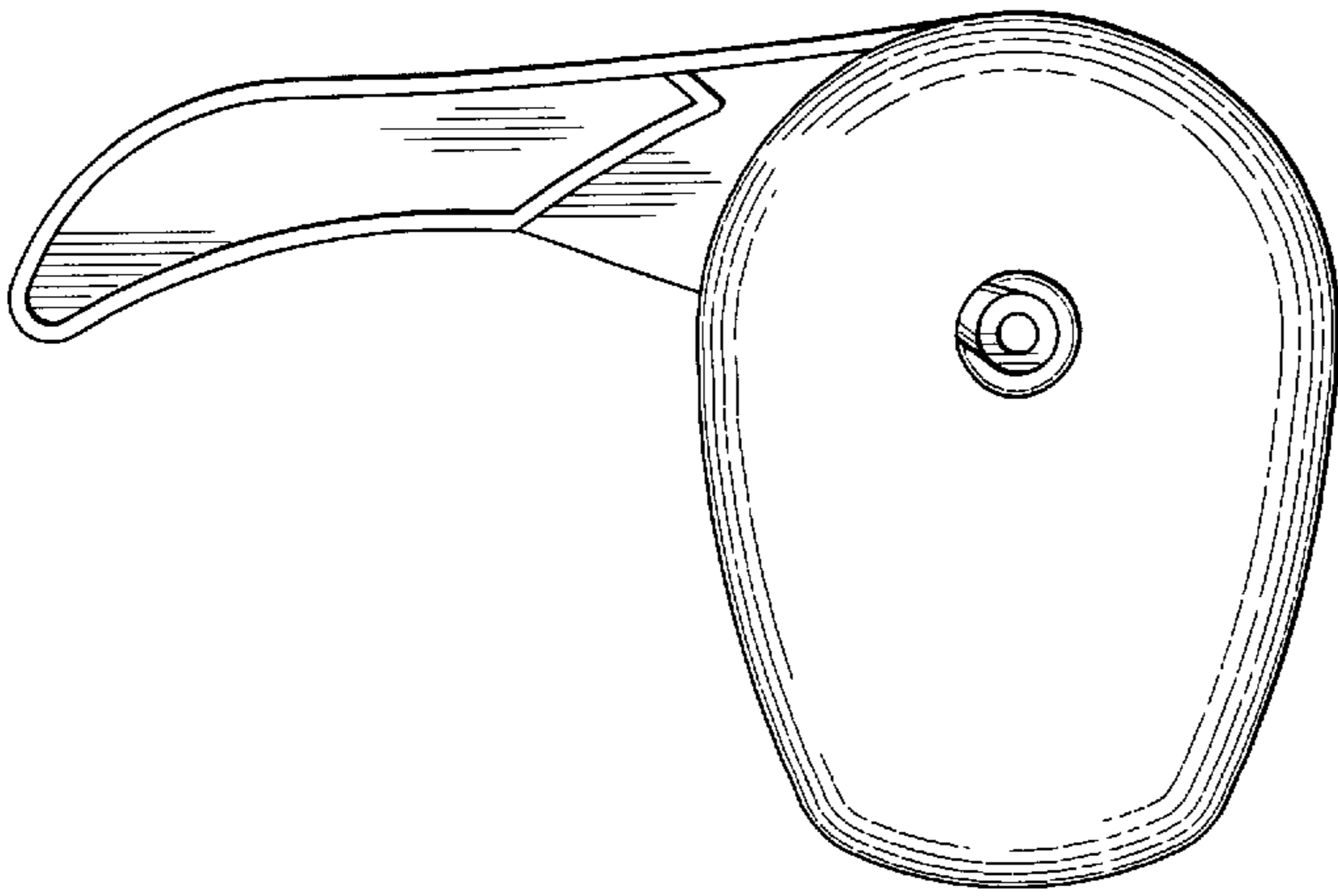

Fig. 1.

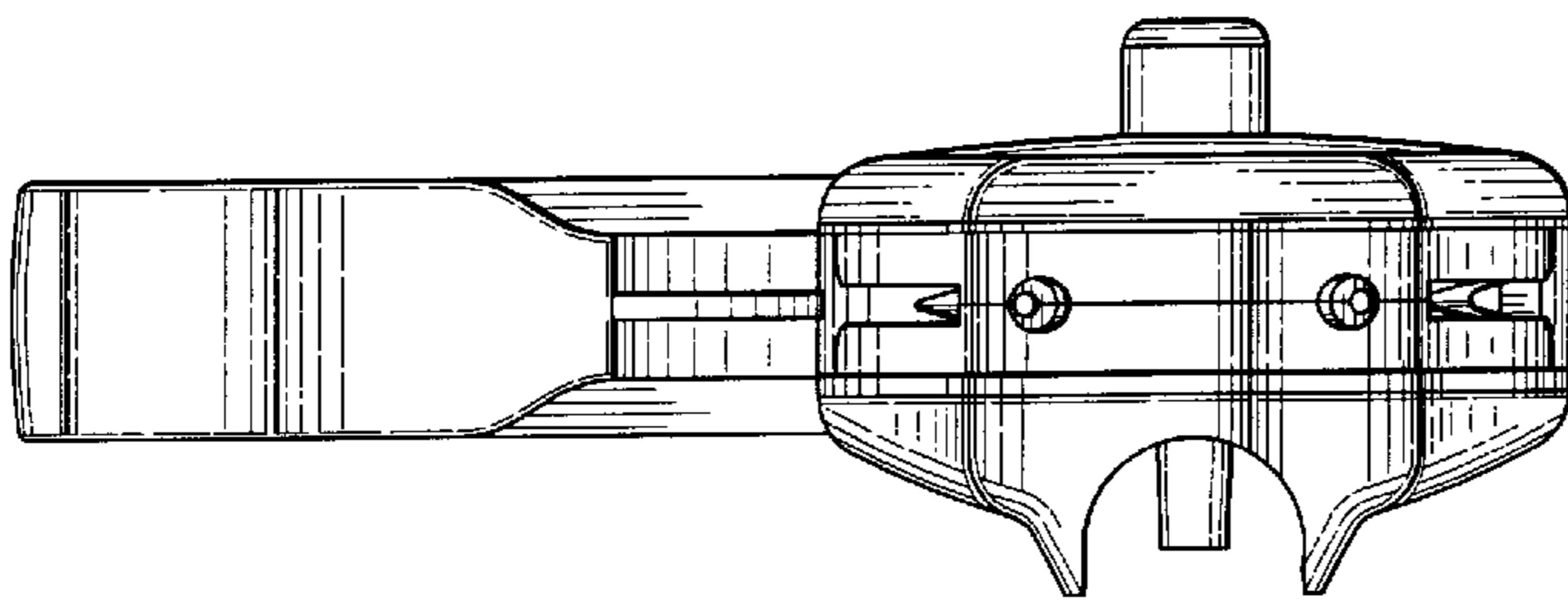

Fig. 2.

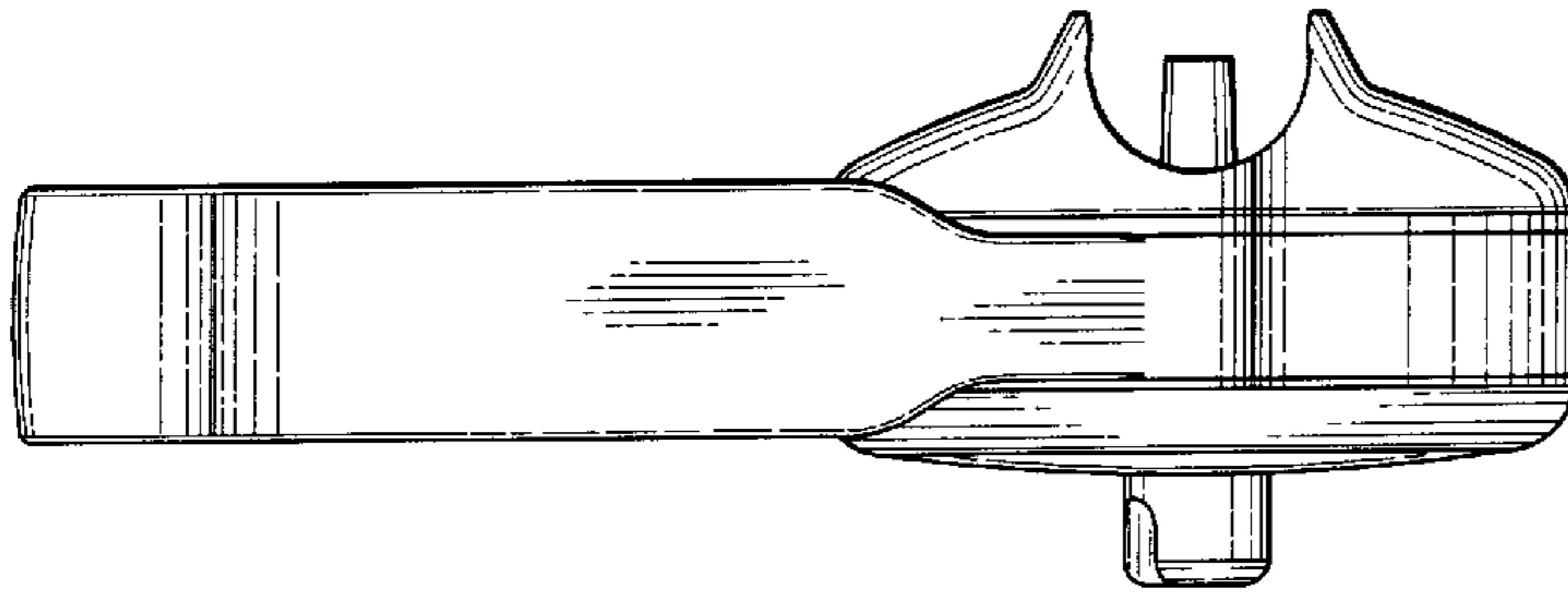

Fig. 3.

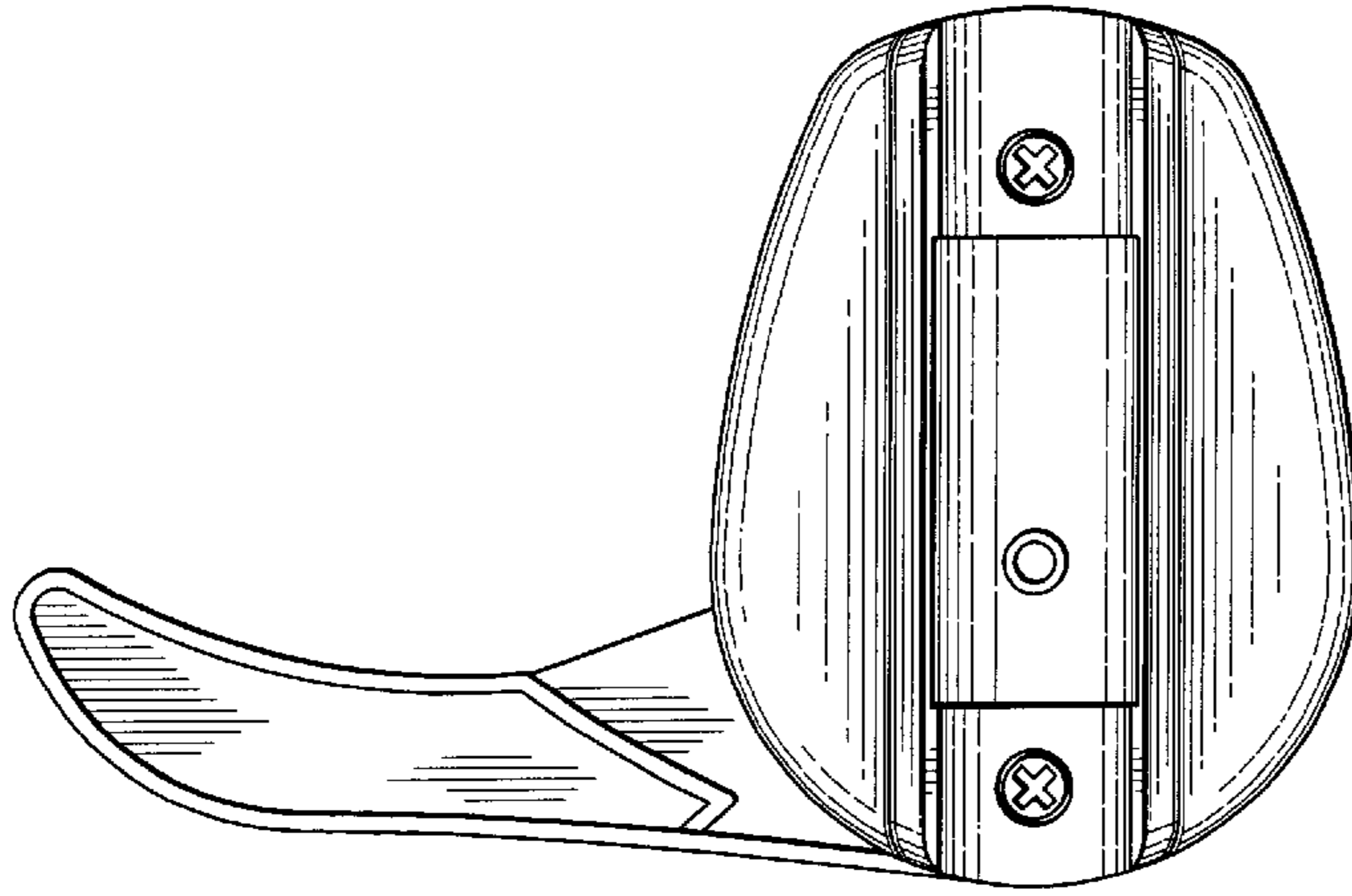

Fig. 4.

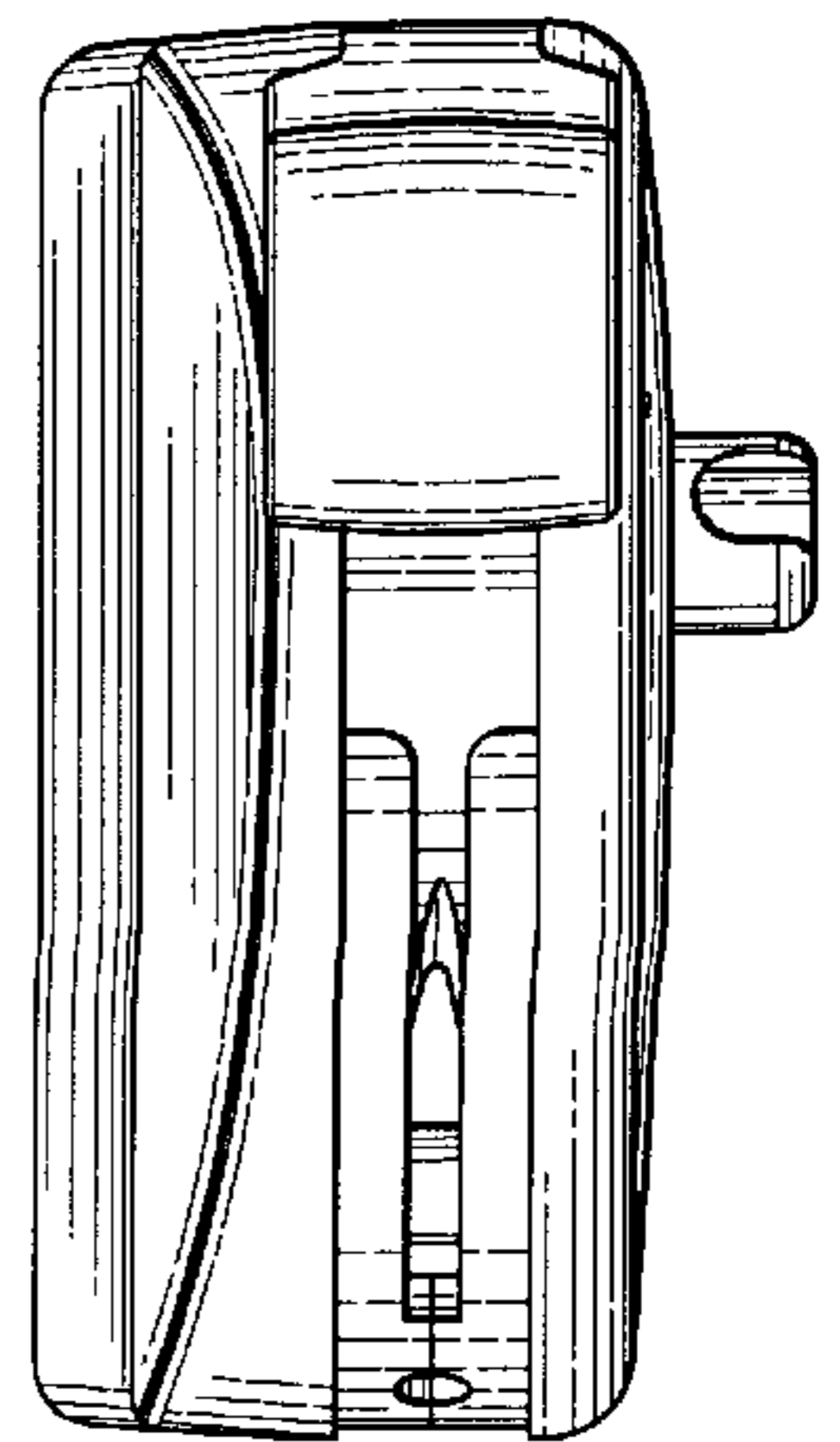

Fig. 5.

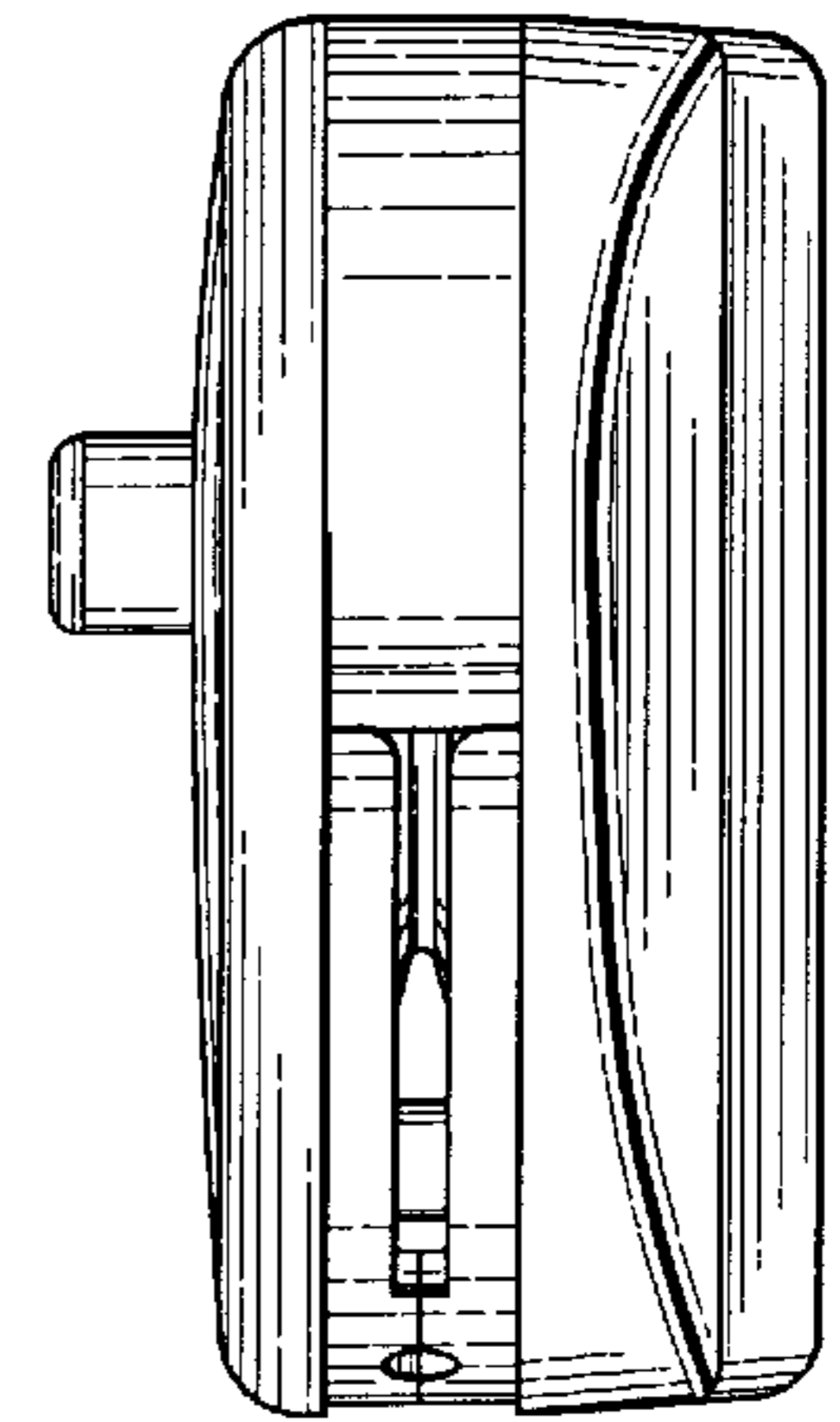

Fig. 6.

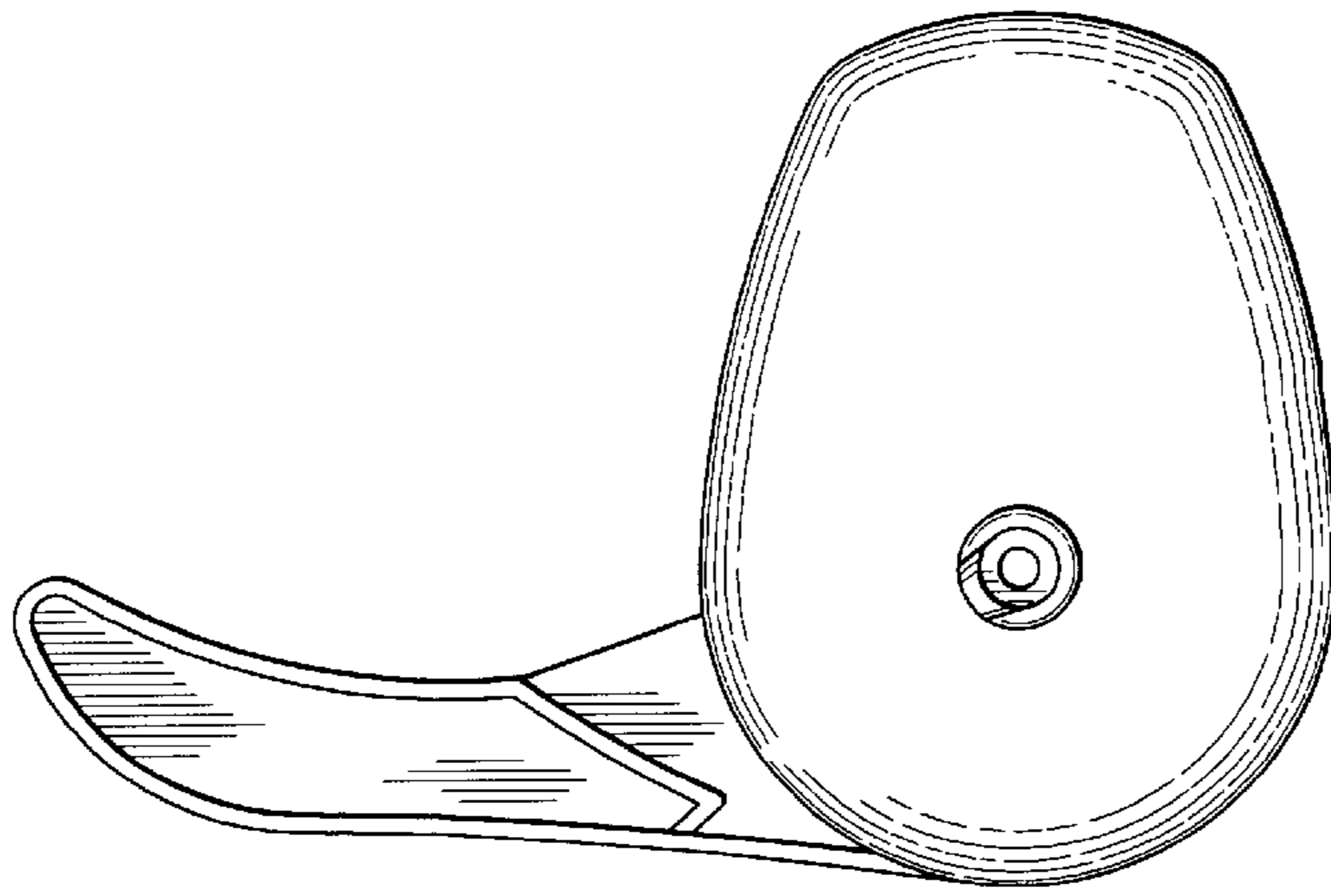

Fig. 7.

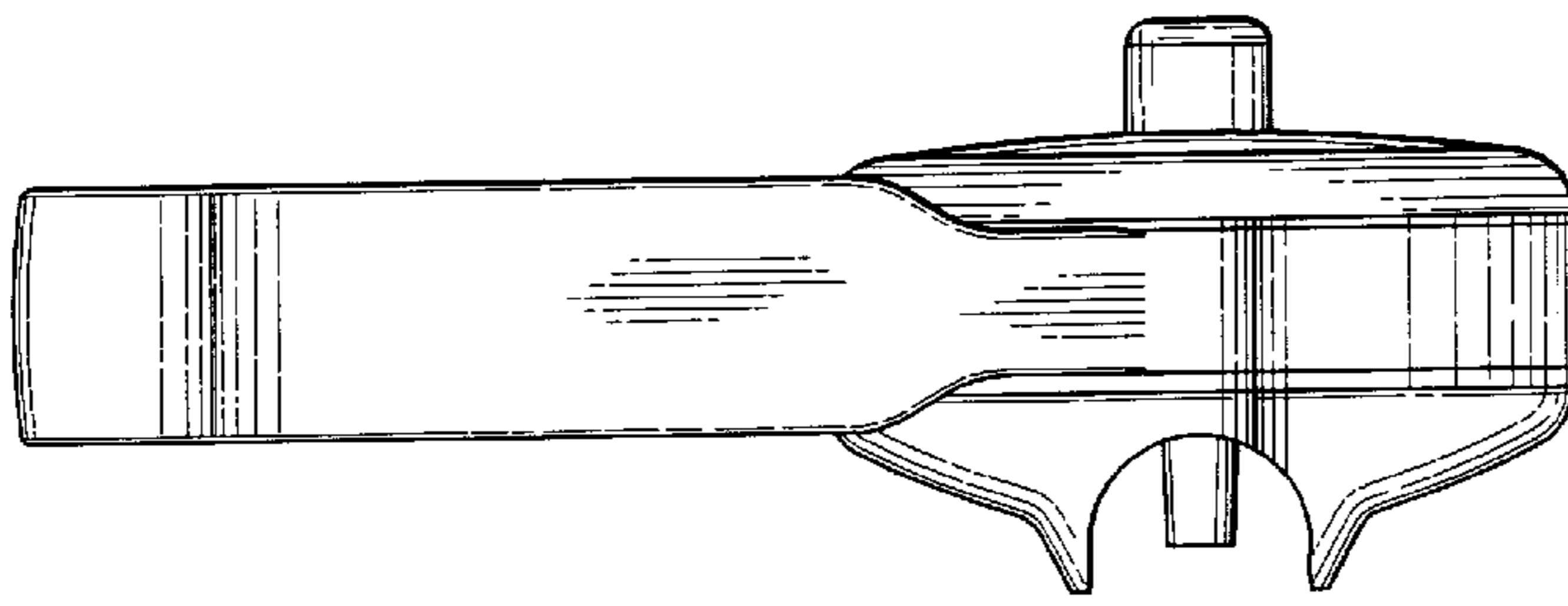

Fig. 8.

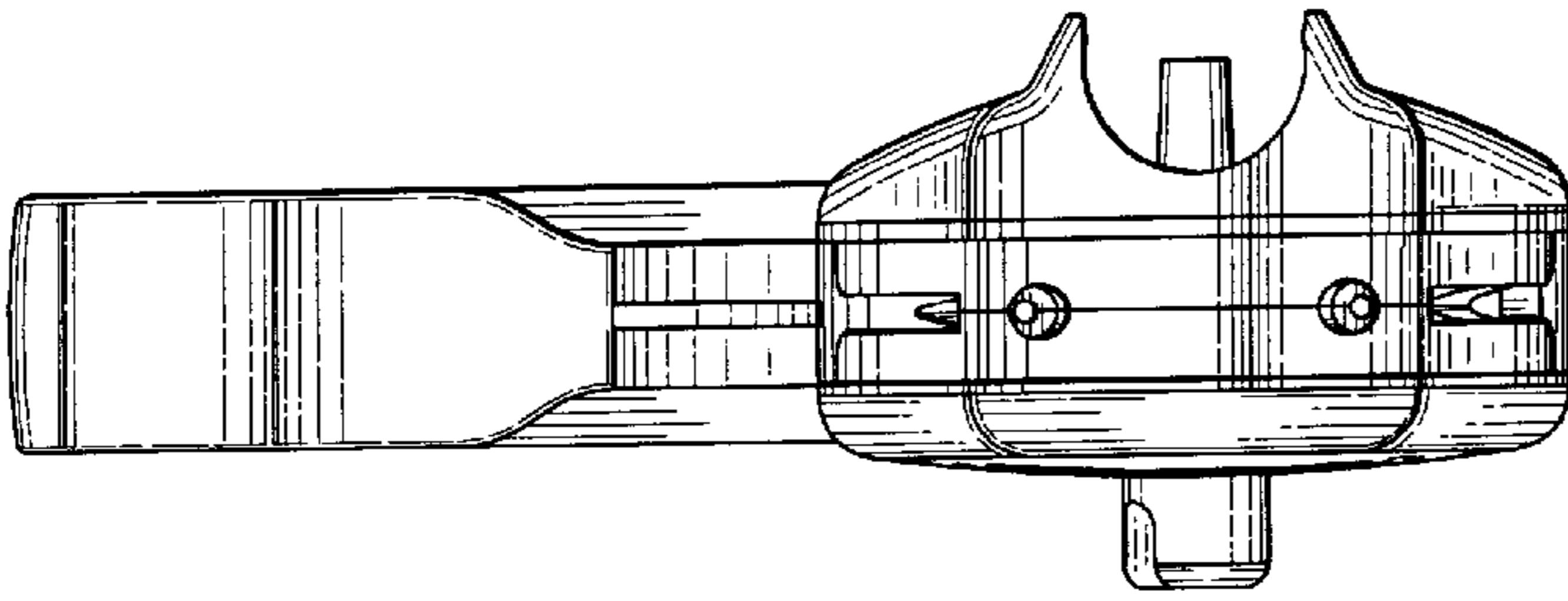

Fig. 9.

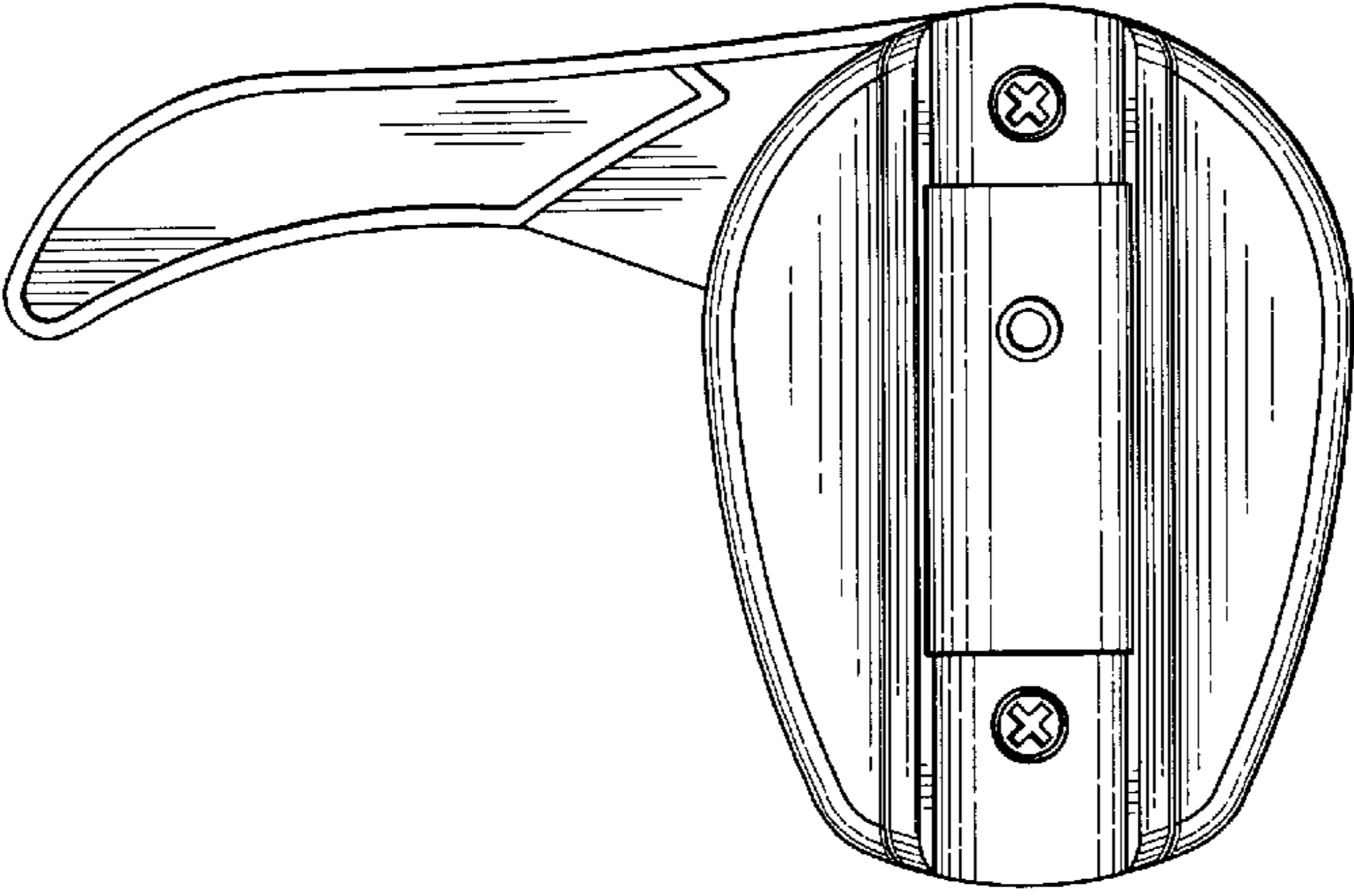

Fig. 10.

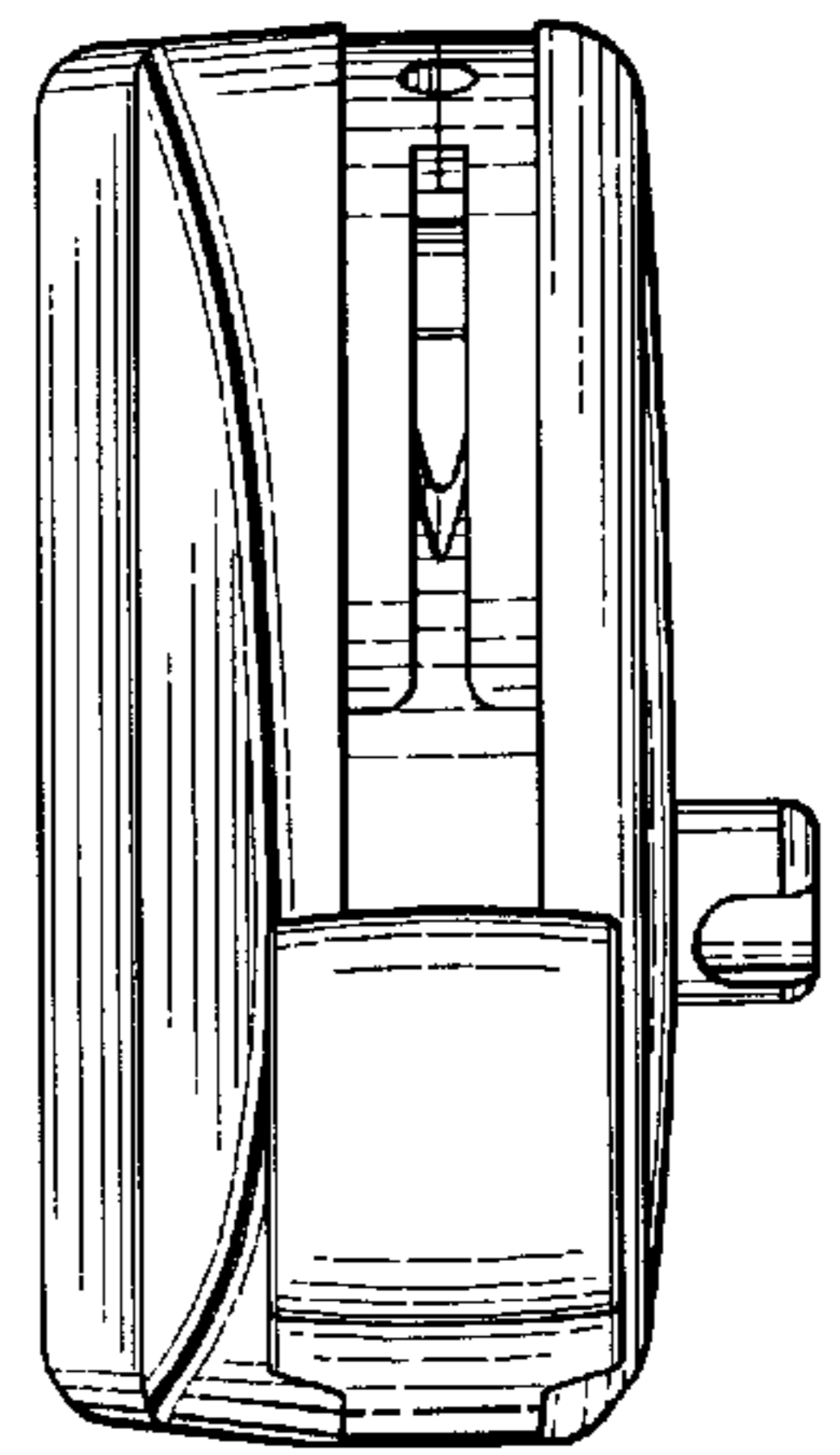

Fig. 11.

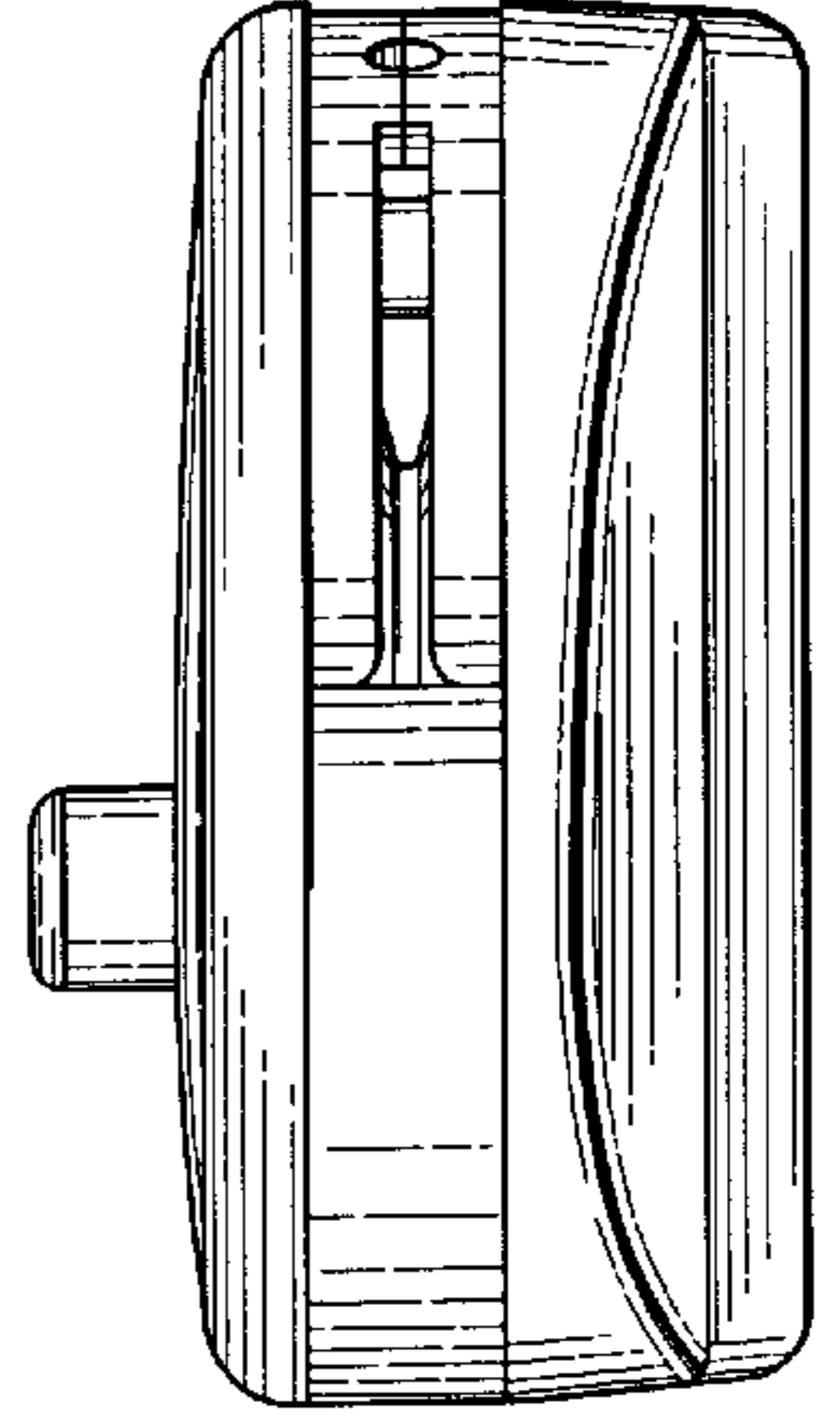

Fig. 12.

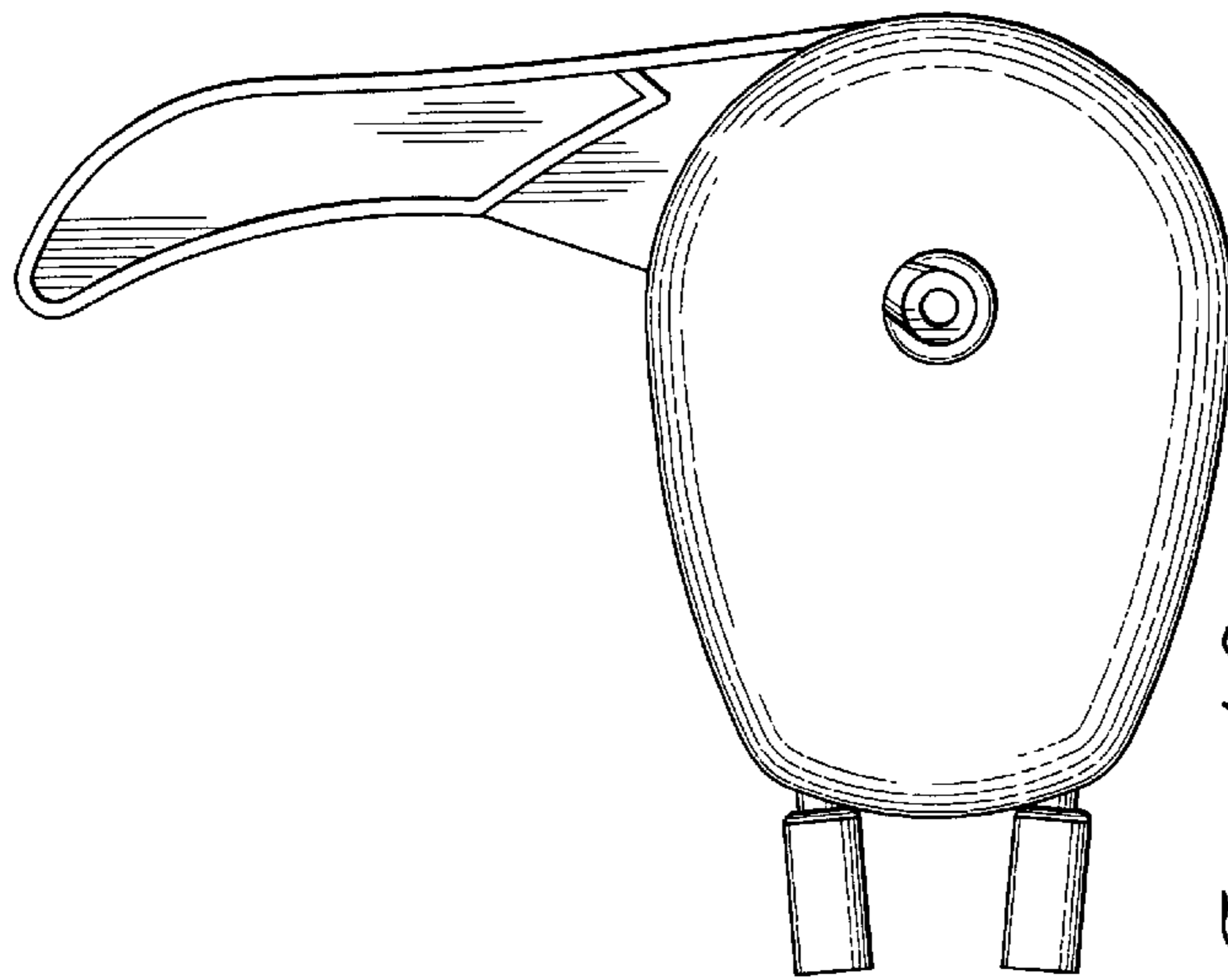

Fig. 13.

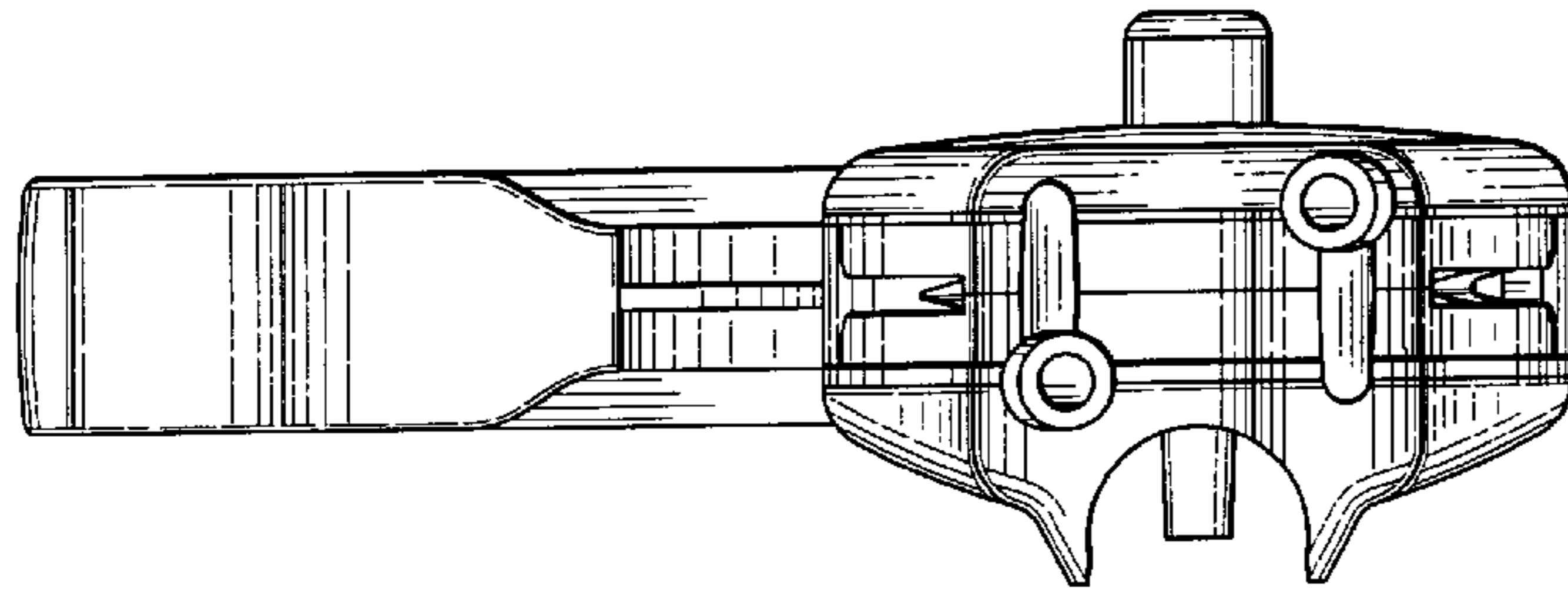

Fig. 14.

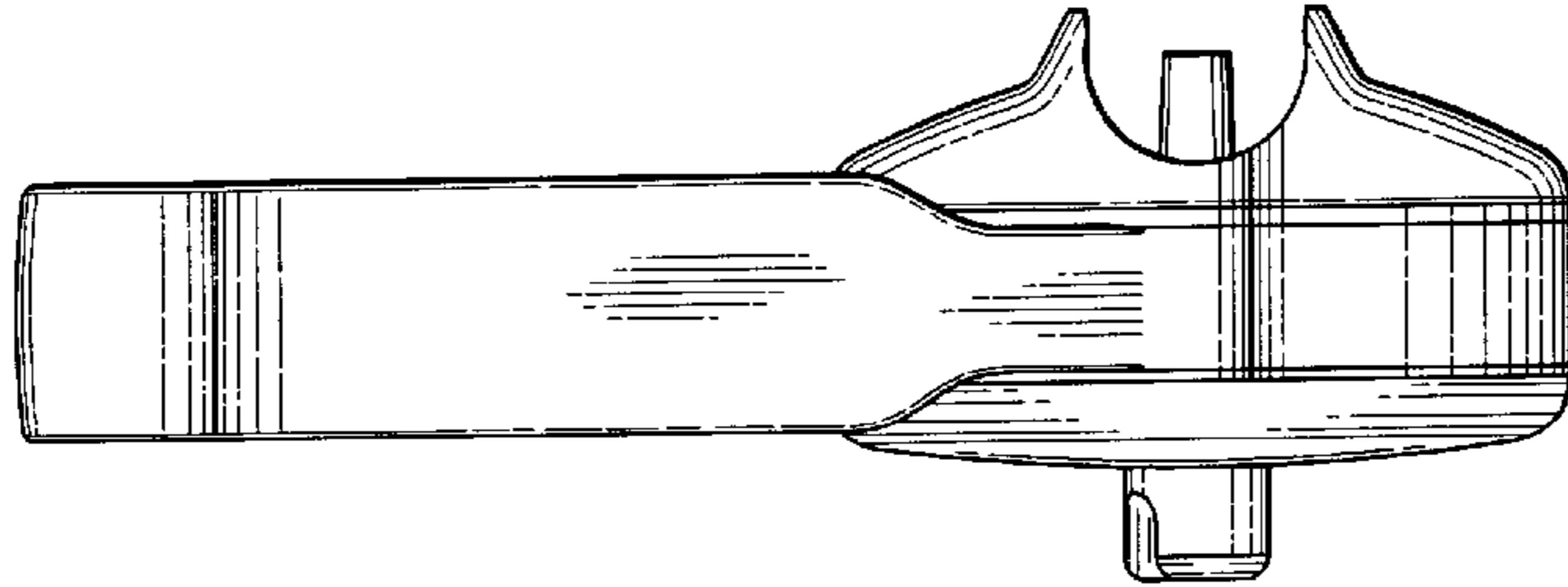

Fig. 15.

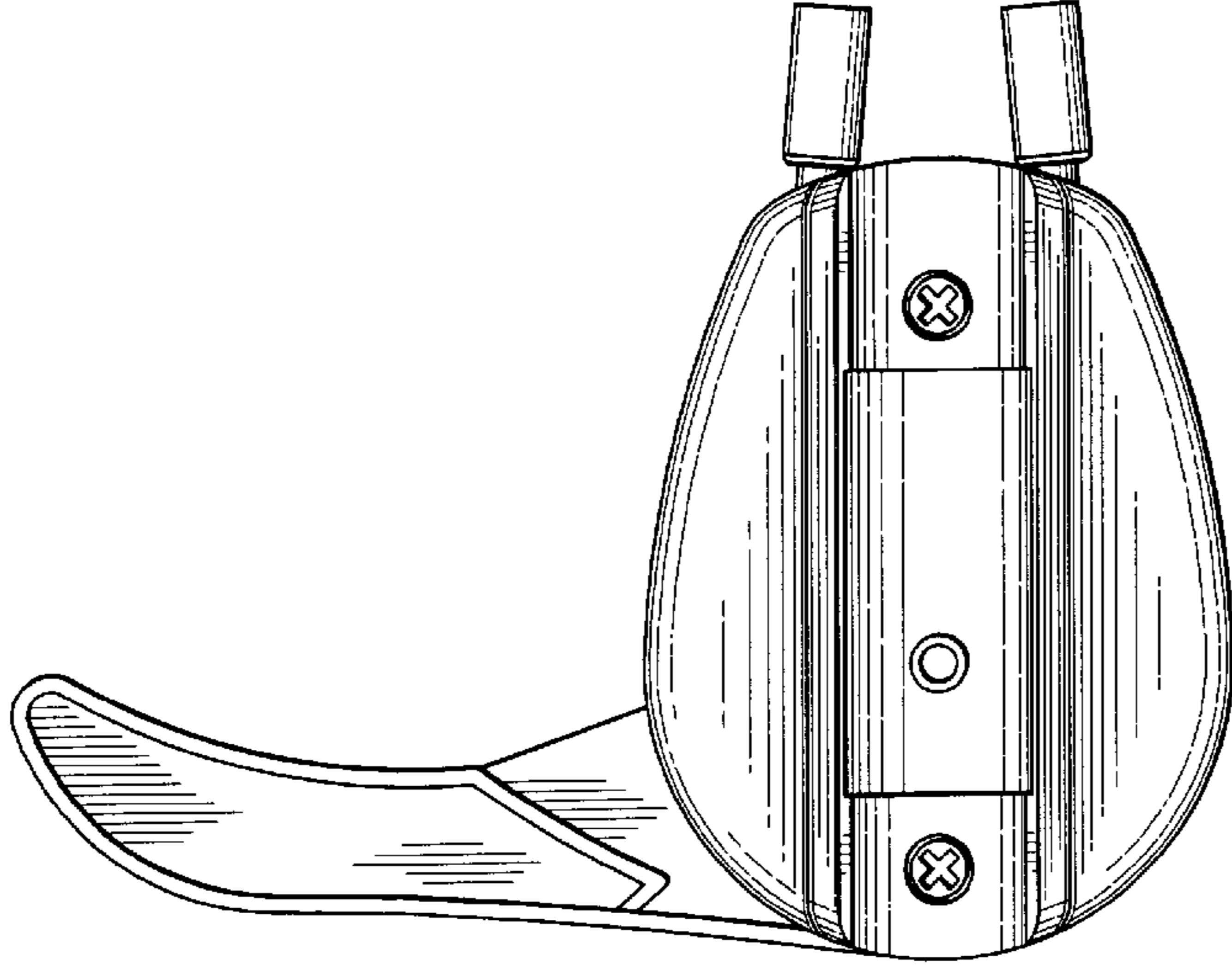

Fig. 16.

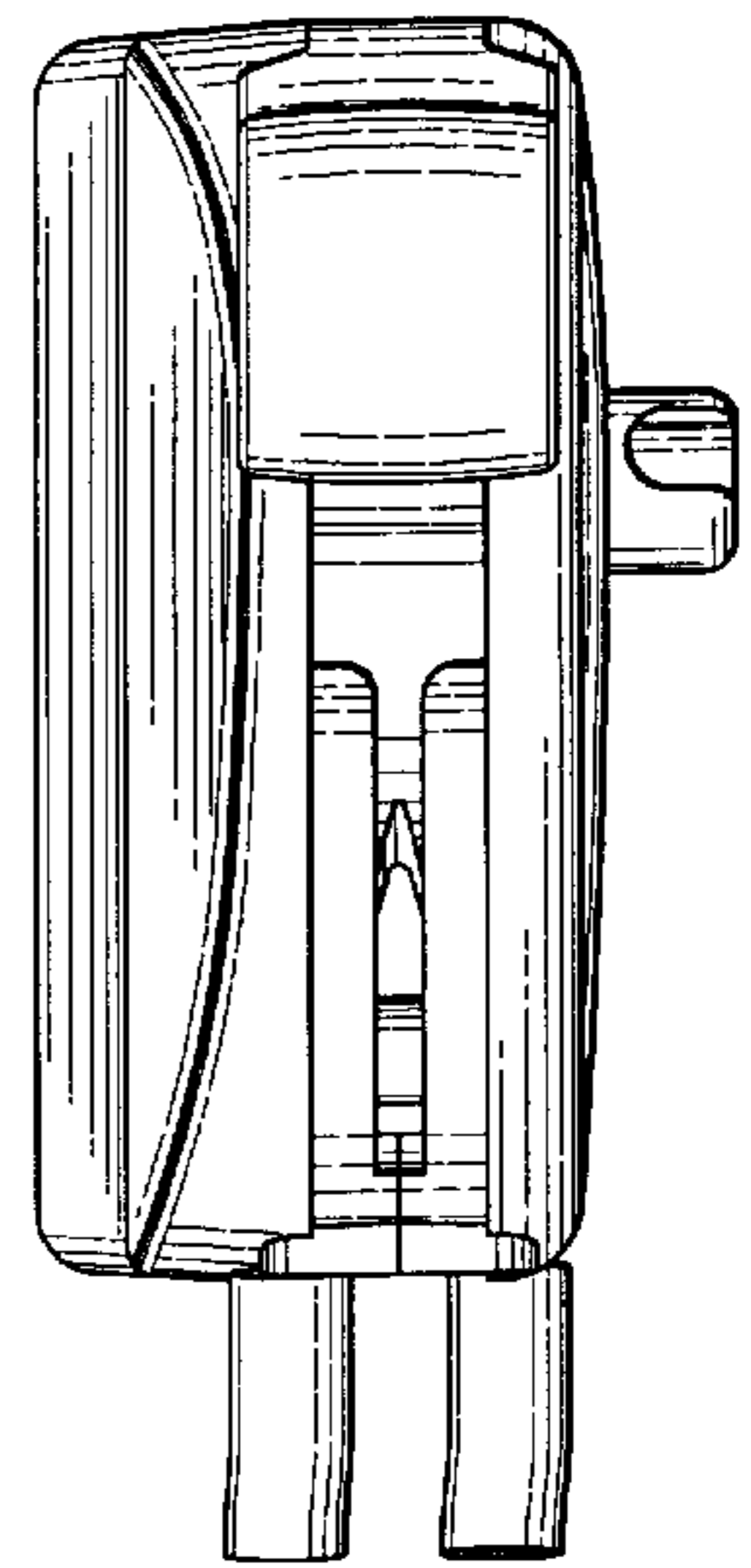

Fig. 17.

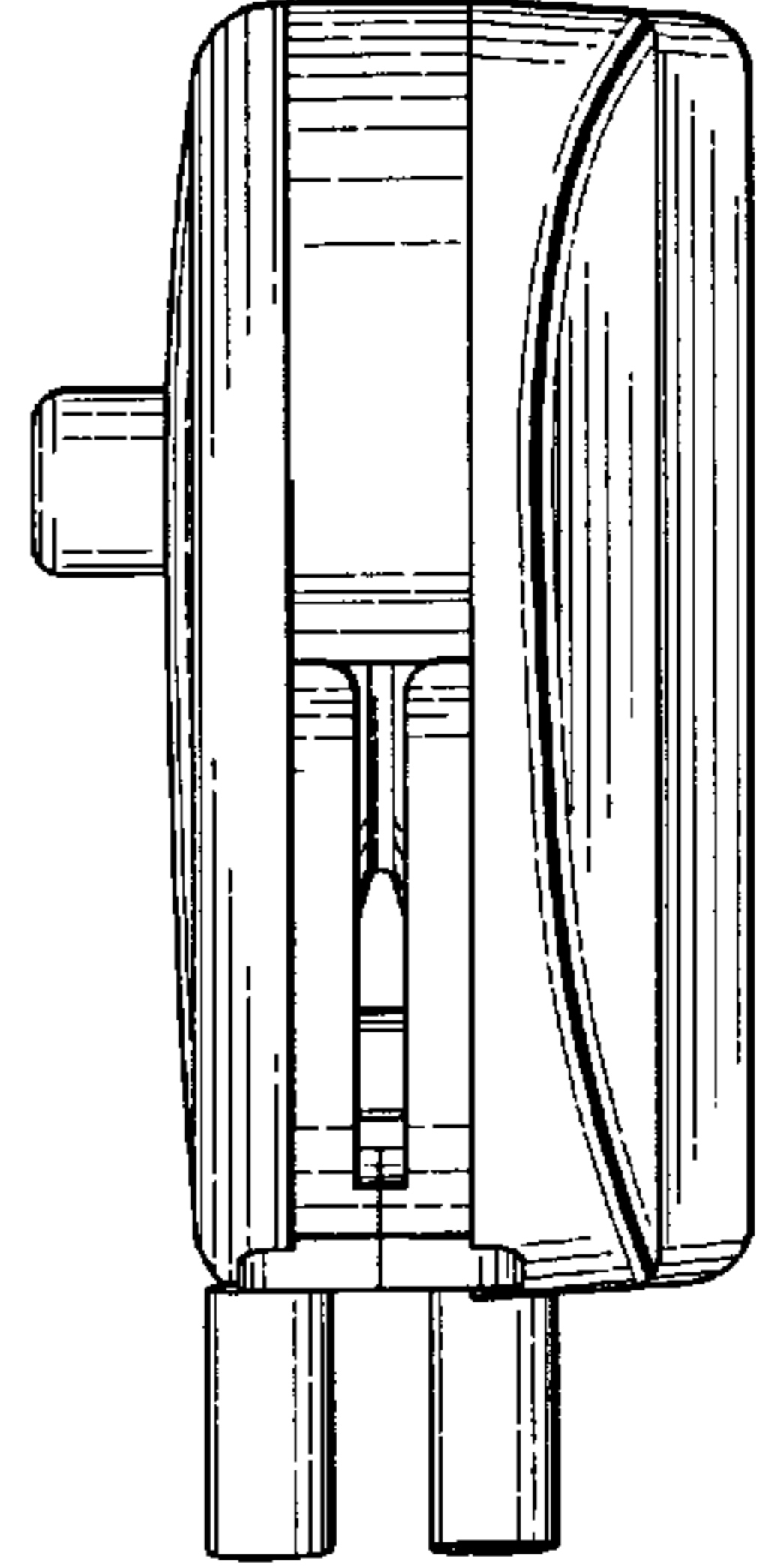

Fig. 18.

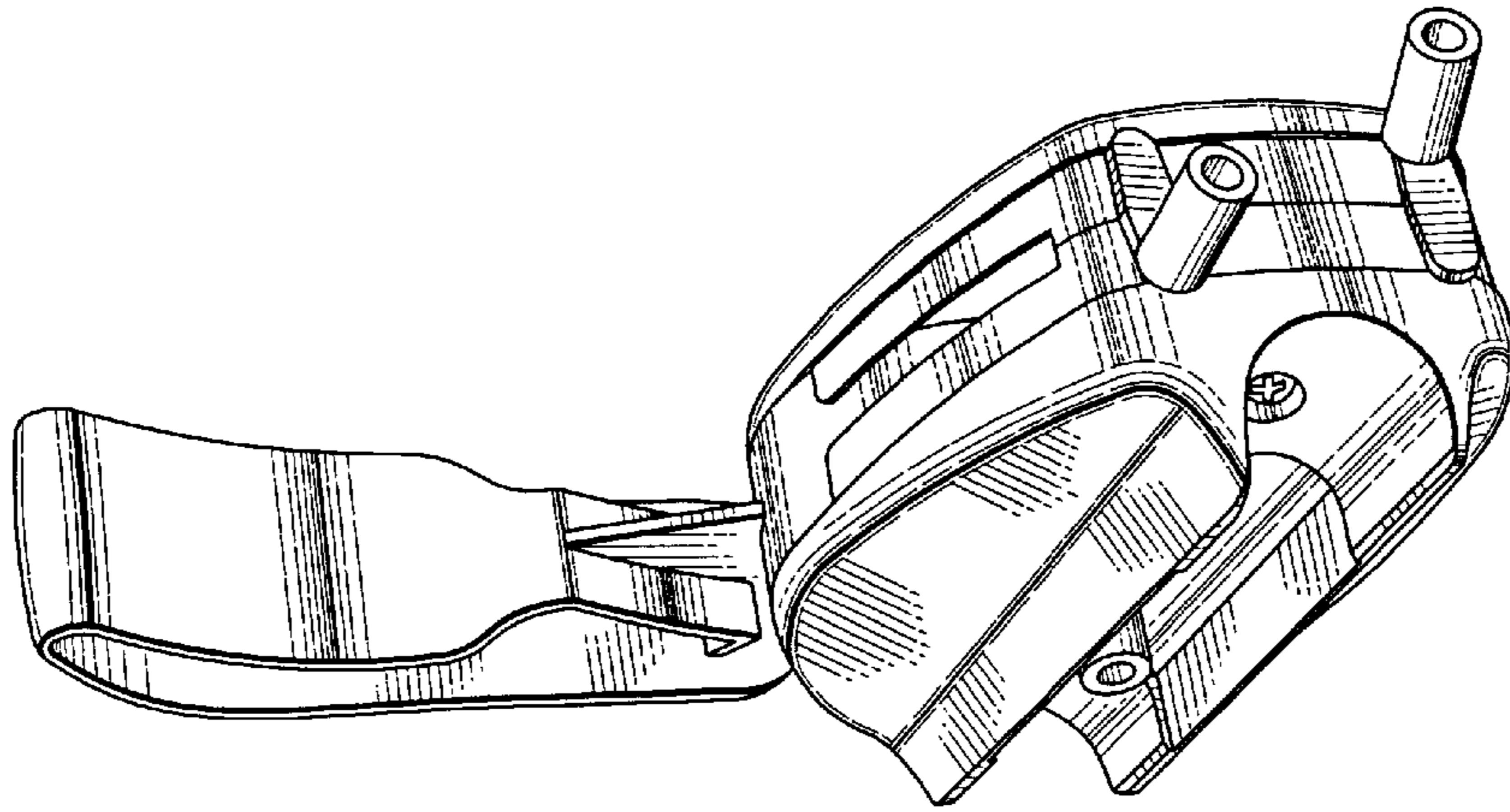

Fig. 19.

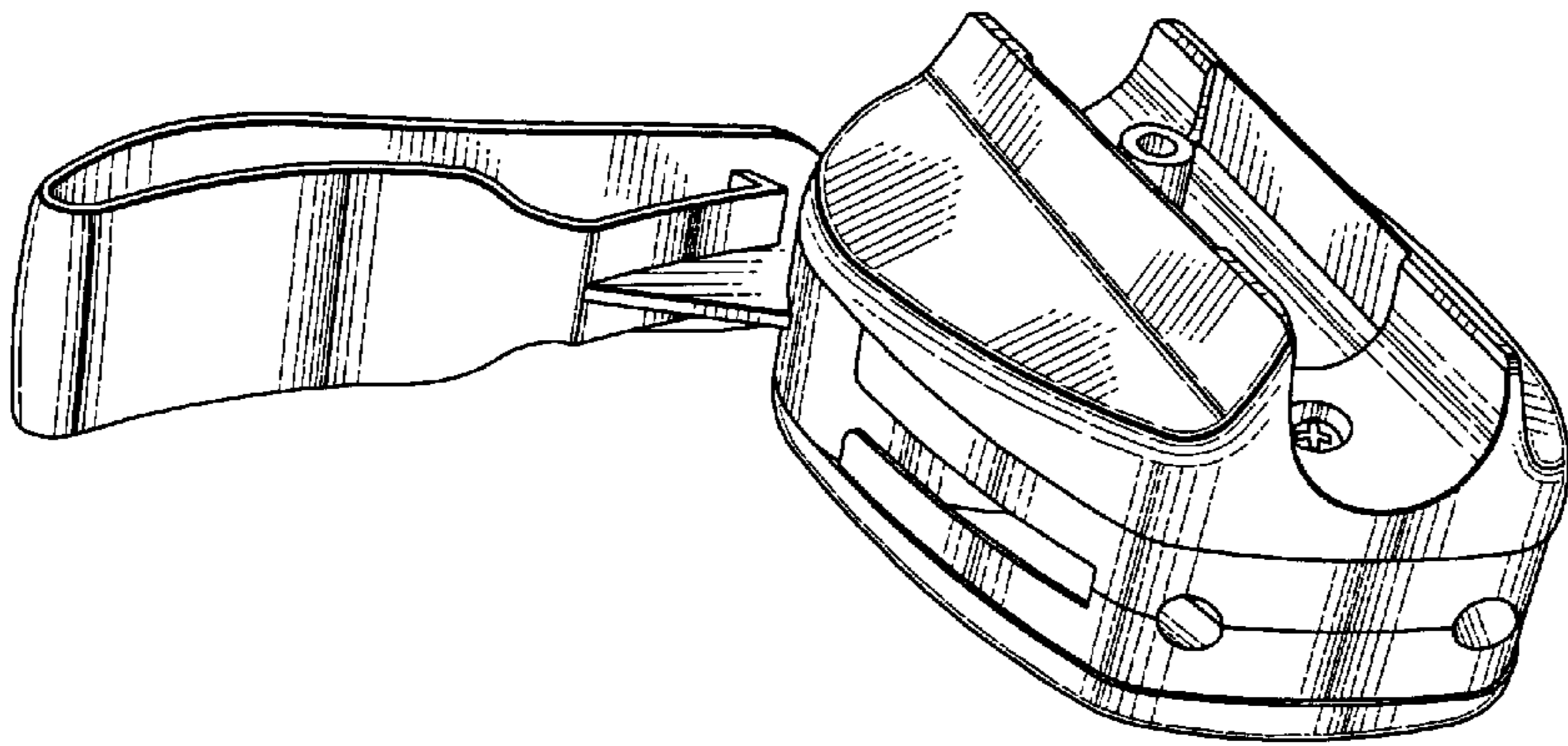

Fig. 20.

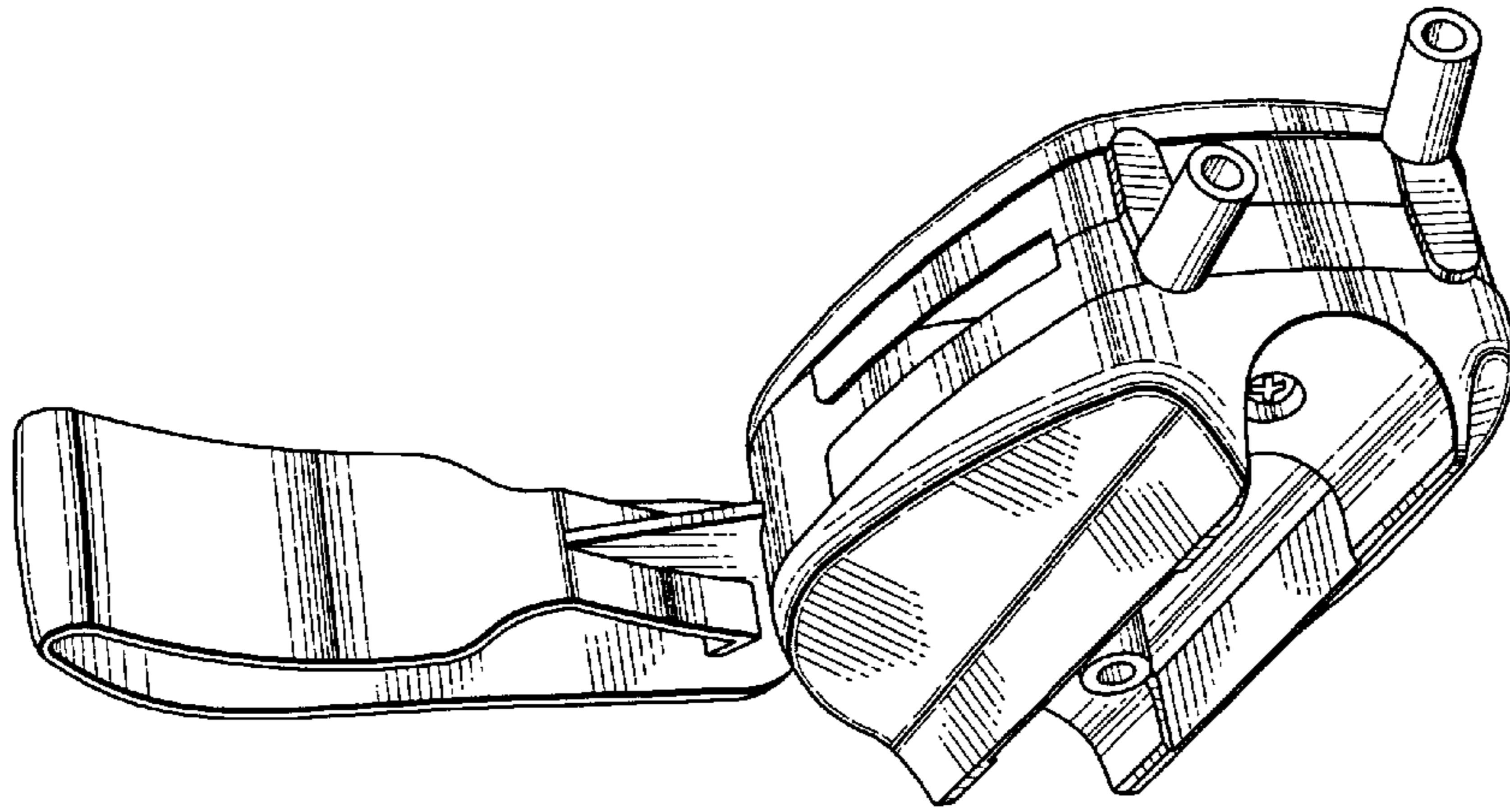

Fig. 21.