



US00D436023S

(12) **United States Design Patent**  
**Johnson**

(10) **Patent No.:** **US D436,023 S**

(45) **Date of Patent:** **\*\* Jan. 9, 2001**

(54) **PULLEY TIRE**

D. 184,346 \* 2/1959 Gerland ..... D8/360  
4,402,678 \* 9/1983 St. John ..... 474/171

(76) Inventor: **William Johnson**, 283 West Coast  
Drive, North Beach, Western Australia  
(AU), 6020

\* cited by examiner

(\*\*) Term: **14 Years**

*Primary Examiner*—Holly Baynham  
(74) *Attorney, Agent, or Firm*—Miles & Stockbridge P.C.;  
John C. Kerins

(21) Appl. No.: **29/115,954**

(22) Filed: **Dec. 27, 1999**

(57) **CLAIM**

(30) **Foreign Application Priority Data**

Jul. 8, 1999 (AU) ..... 2145/99

The ornamental design for a pulley tire, as shown and described.

(51) **LOC (7) Cl.** ..... **08-05**

(52) **U.S. Cl.** ..... **D8/360**

(58) **Field of Search** ..... D8/360; 211/119.04,  
211/119.05; 474/170, 169, 166, 171

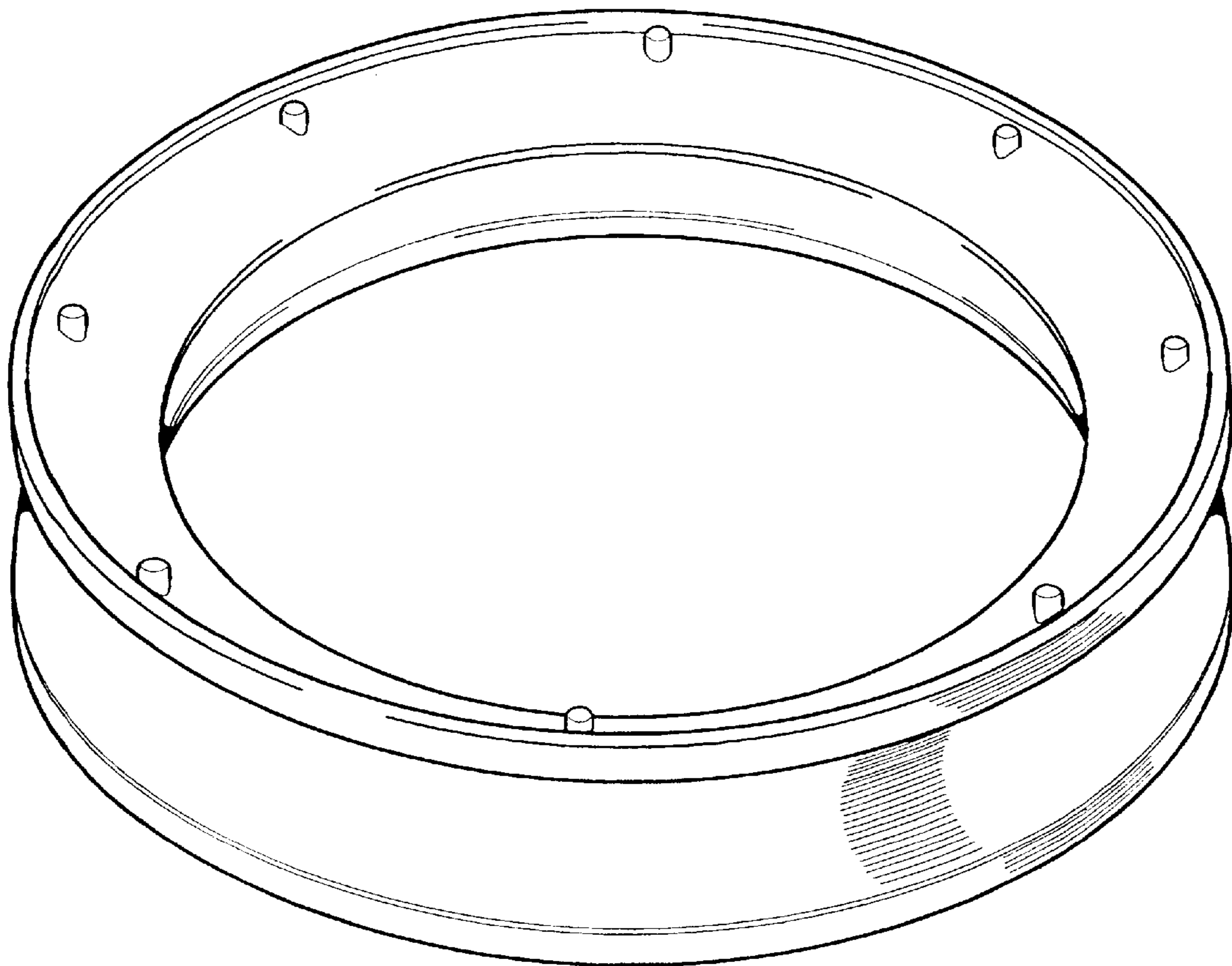
**DESCRIPTION**

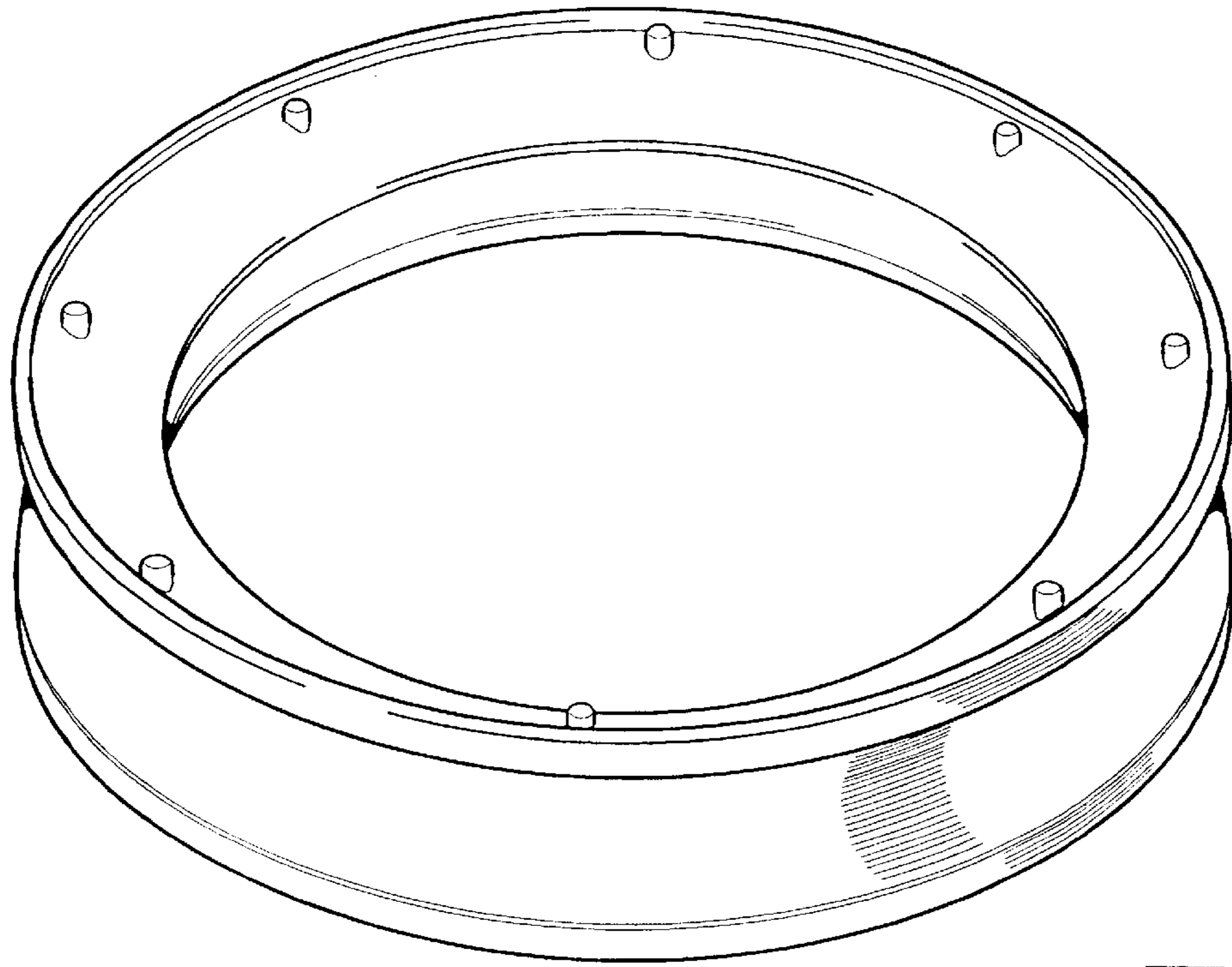
(56) **References Cited**

**U.S. PATENT DOCUMENTS**

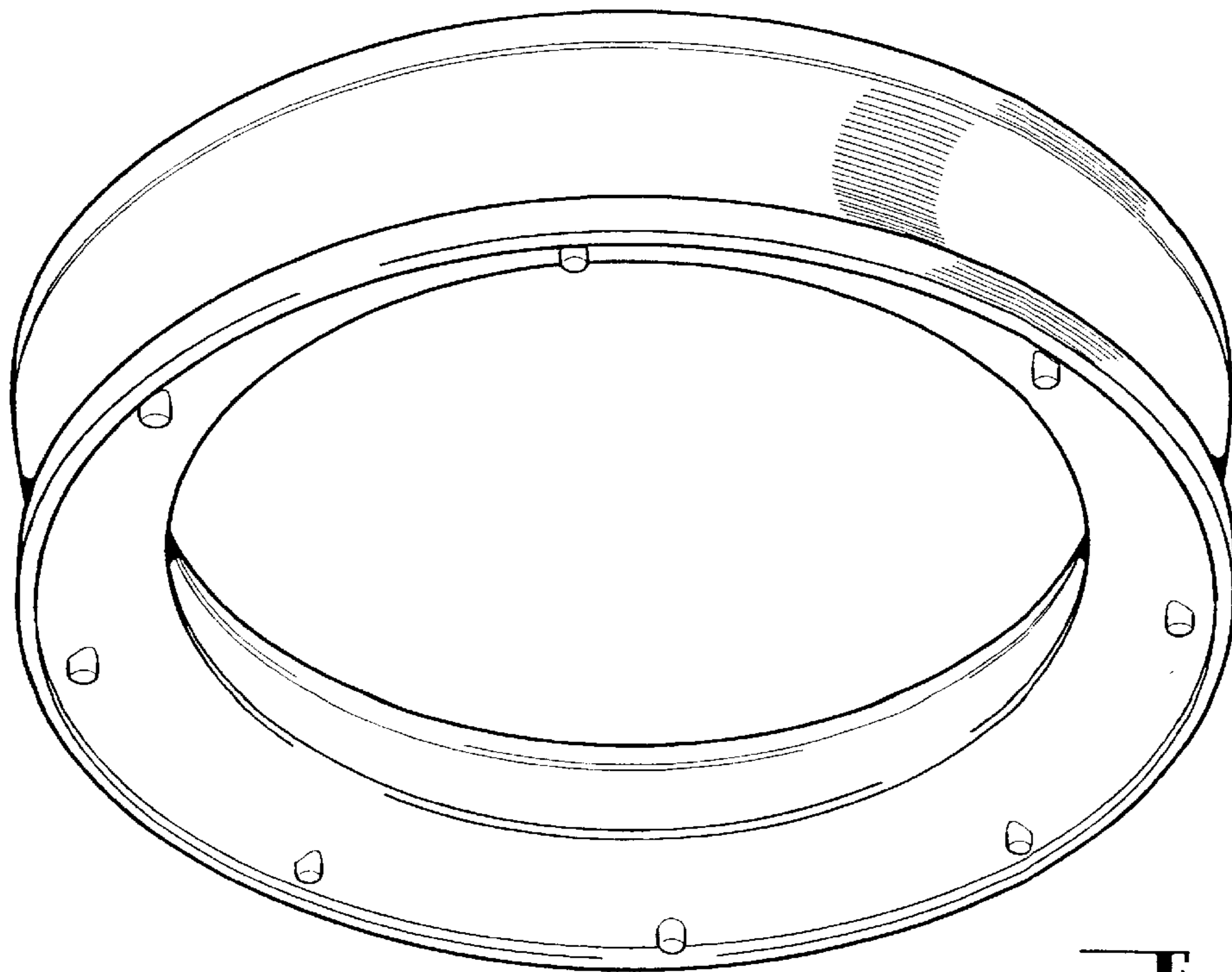
D. 33,975 \* 1/1901 Gardner ..... D8/360

**1 Claim, 2 Drawing Sheets**

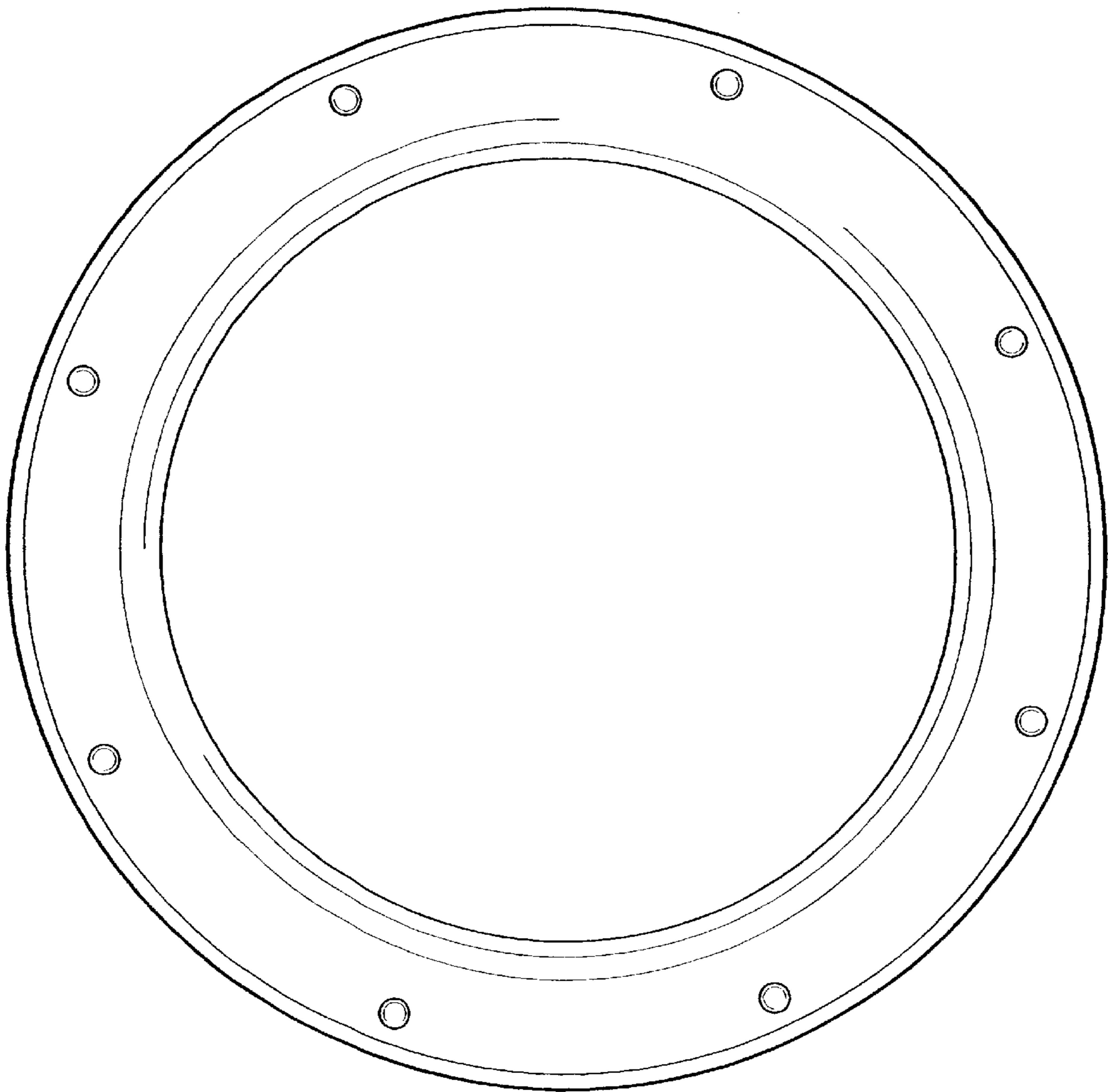




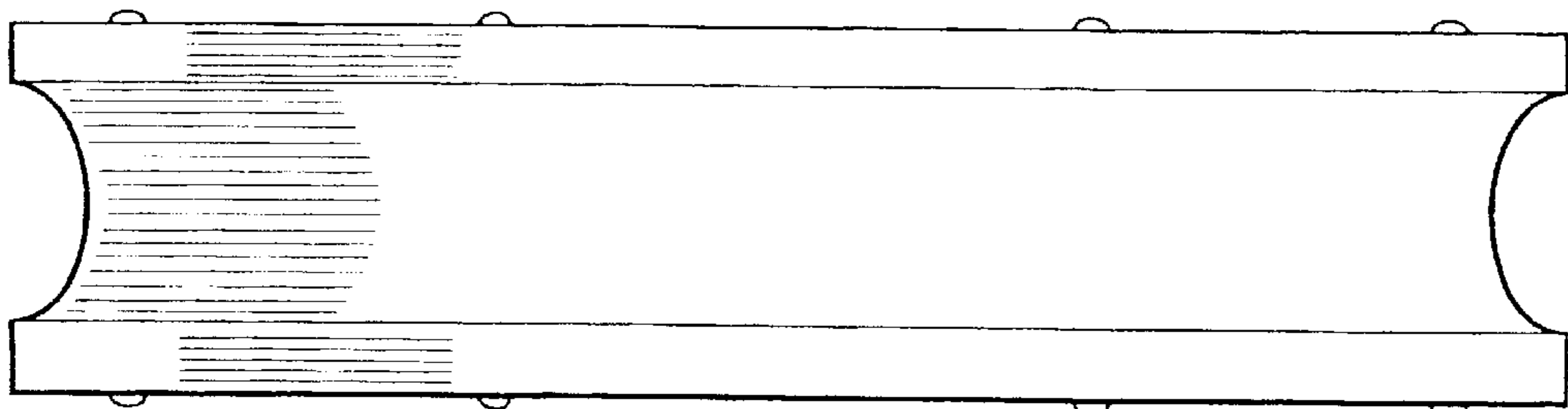
**Fig. 1.**



**Fig. 2.**



**Fig. 3.**



**Fig. 4.**