



US00D435921S

(12) **United States Design Patent**
Braley et al.

(10) **Patent No.:** **US D435,921 S**

(45) **Date of Patent:** **** Jan. 2, 2001**

(54) **STRING OF DECORATIVE LIGHTS**

DESCRIPTION

(76) Inventors: **Jennifer A. Braley; John H. Braley**,
both of 88 Morrill Hill Rd., Andover,
NH (US) 03216

(**) Term: **14 Years**

(21) Appl. No.: **29/096,821**

(22) Filed: **Nov. 20, 1998**

(51) **LOC (7) Cl.** **26-05**

(52) **U.S. Cl.** **D26/25**

(58) **Field of Search** D26/25, 73, 118,
D26/125; 362/806, 808, 810; D11/138,
163; D21/548, 549, 550

(56) **References Cited**

U.S. PATENT DOCUMENTS

- D. 374,293 * 10/1996 Streger et al. D26/25
- D. 411,319 * 6/1999 Baker D26/25

* cited by examiner

Primary Examiner—Susan J. Lucas

(74) *Attorney, Agent, or Firm*—Michael J. Persson;
Lawson, Philpot & Persson, P.C.

(57) **CLAIM**

The ornamental design for a string of decorative lights, as shown and described.

FIG. 1 is a perspective view of a first embodiment of a string of decorative lights showing replicas of Chevrolet, automobile, a Pontiac automobile, and a Ford automobile on the light string.

FIGS. 2 through 7 are respectively side, perspective, front, rear, top, and bottom views of the Chevrolet automobile hung from the light string, the Ford and Pontiac being omitted for convenience of illustration;

FIG. 8 is a perspective view of a second embodiment of a string of Chevrolet race cars only.

FIGS. 9 through 14 are respectively side, perspective, front, rear, top, and bottom views of the Ford automobile hung from the light string, the Chevrolet and Pontiac being omitted for convenience of illustration

FIG. 15 is a side perspective view of a third embodiment of the design consisting of a string of Ford race cars;

FIGS. 16 through 21 are respectively side, perspective, front, rear, top, and bottom views of the Pontiac automobile hung from the light string, the Chevrolet and Ford being omitted for convenience of illustration; and

FIG. 22 is a fourth embodiment of the design consisting of a string of Pontiac race cars.

The light string is understood to have indefinite length.

The broken lines are shown for illustrative purposes and are not part of the claimed design.

1 Claim, 22 Drawing Sheets

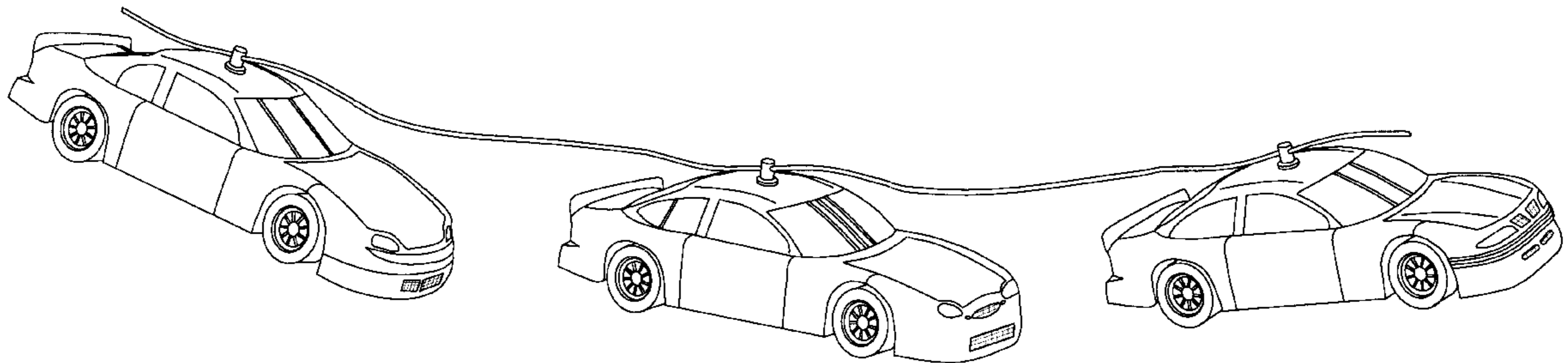

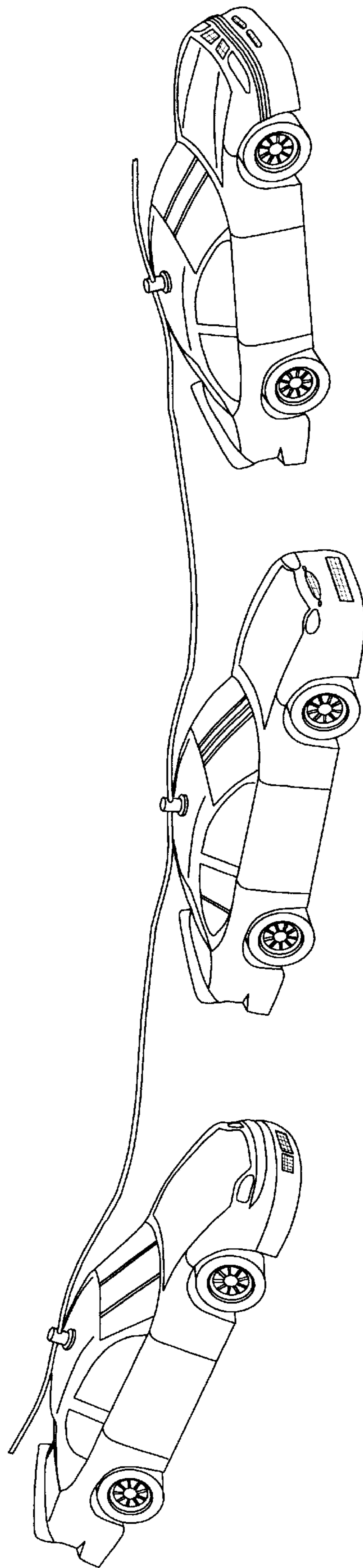

FIG. 1

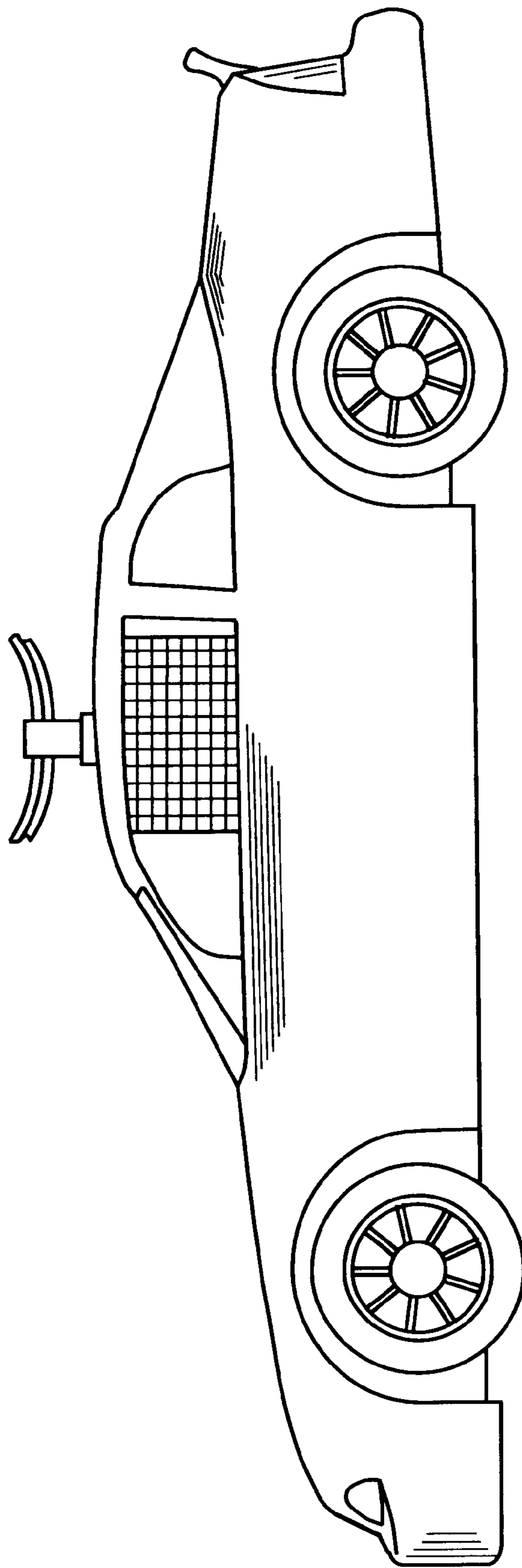

FIG. 2

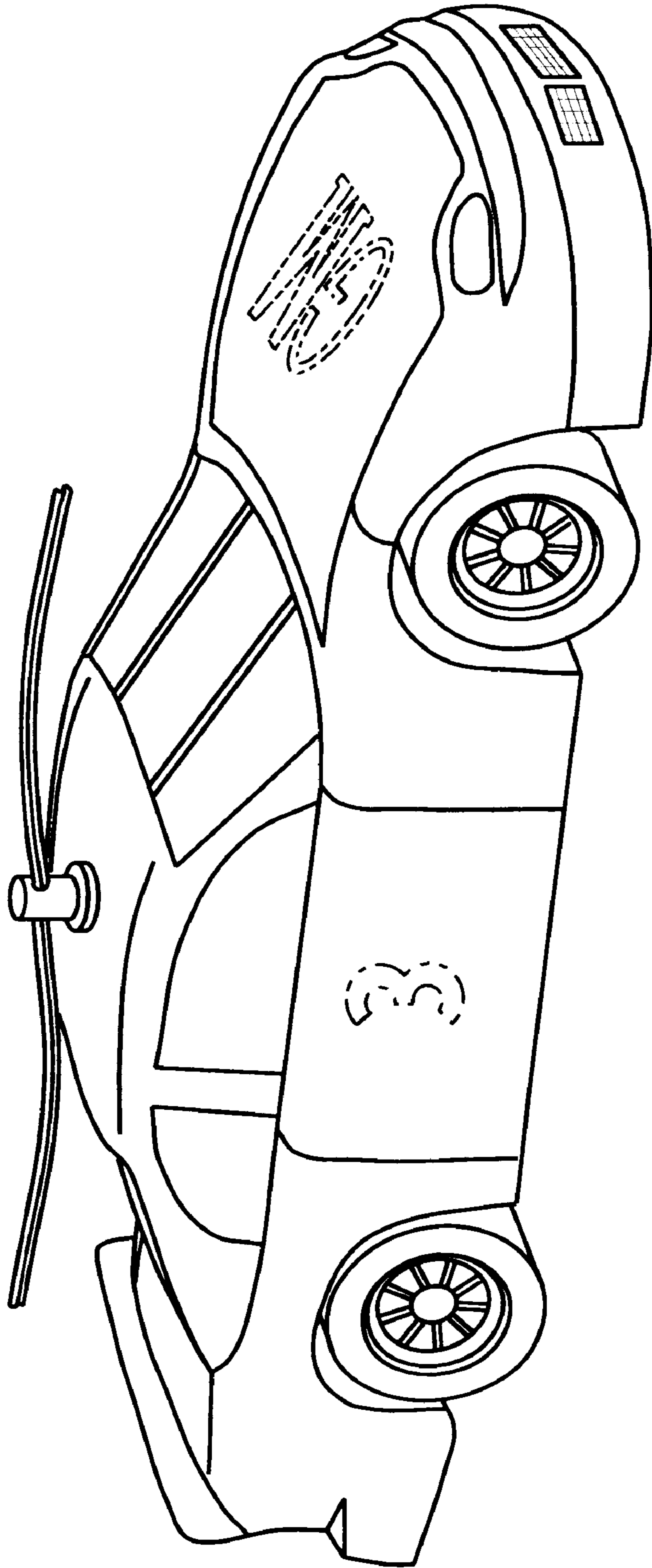

FIG. 3

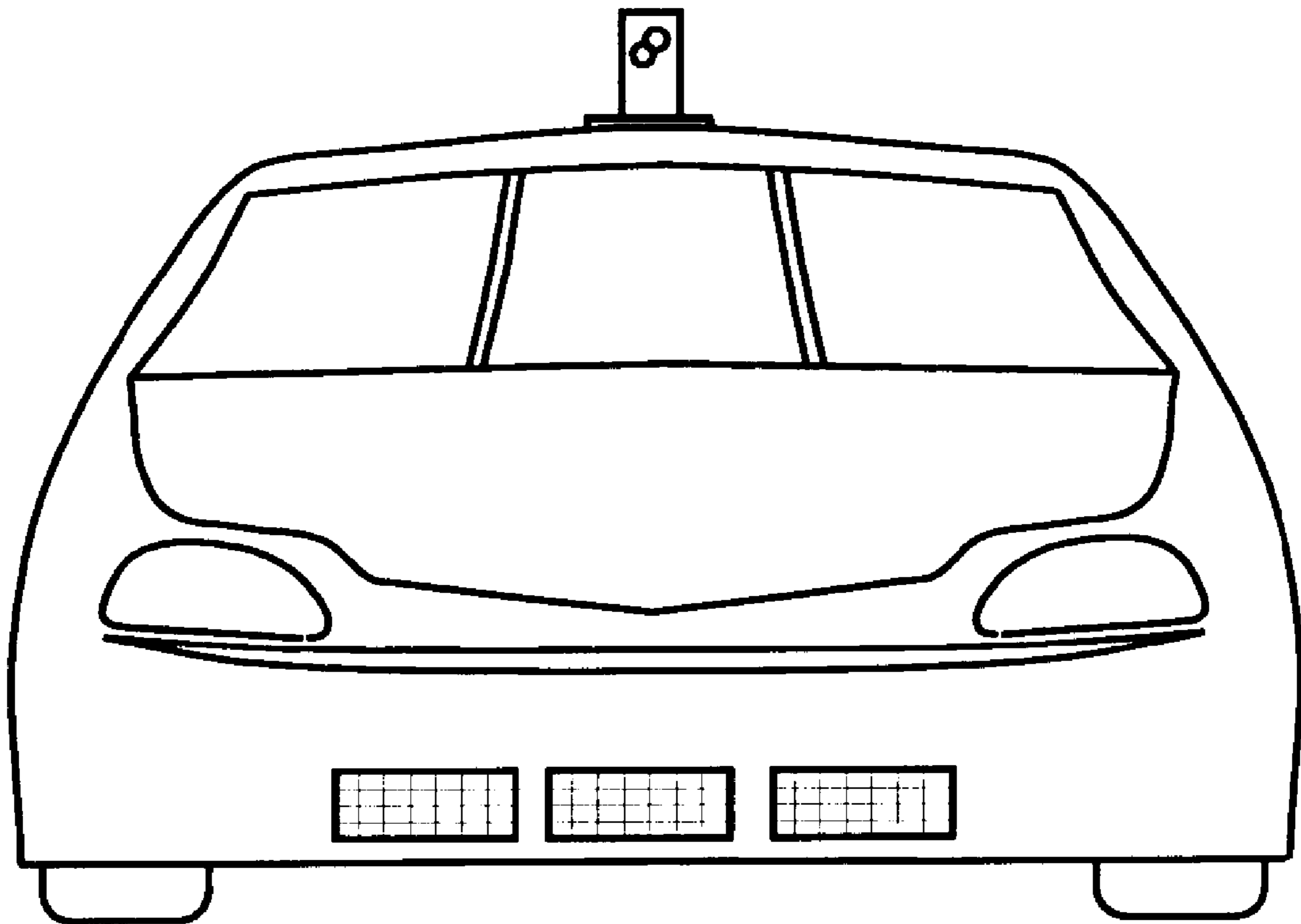

FIG. 4

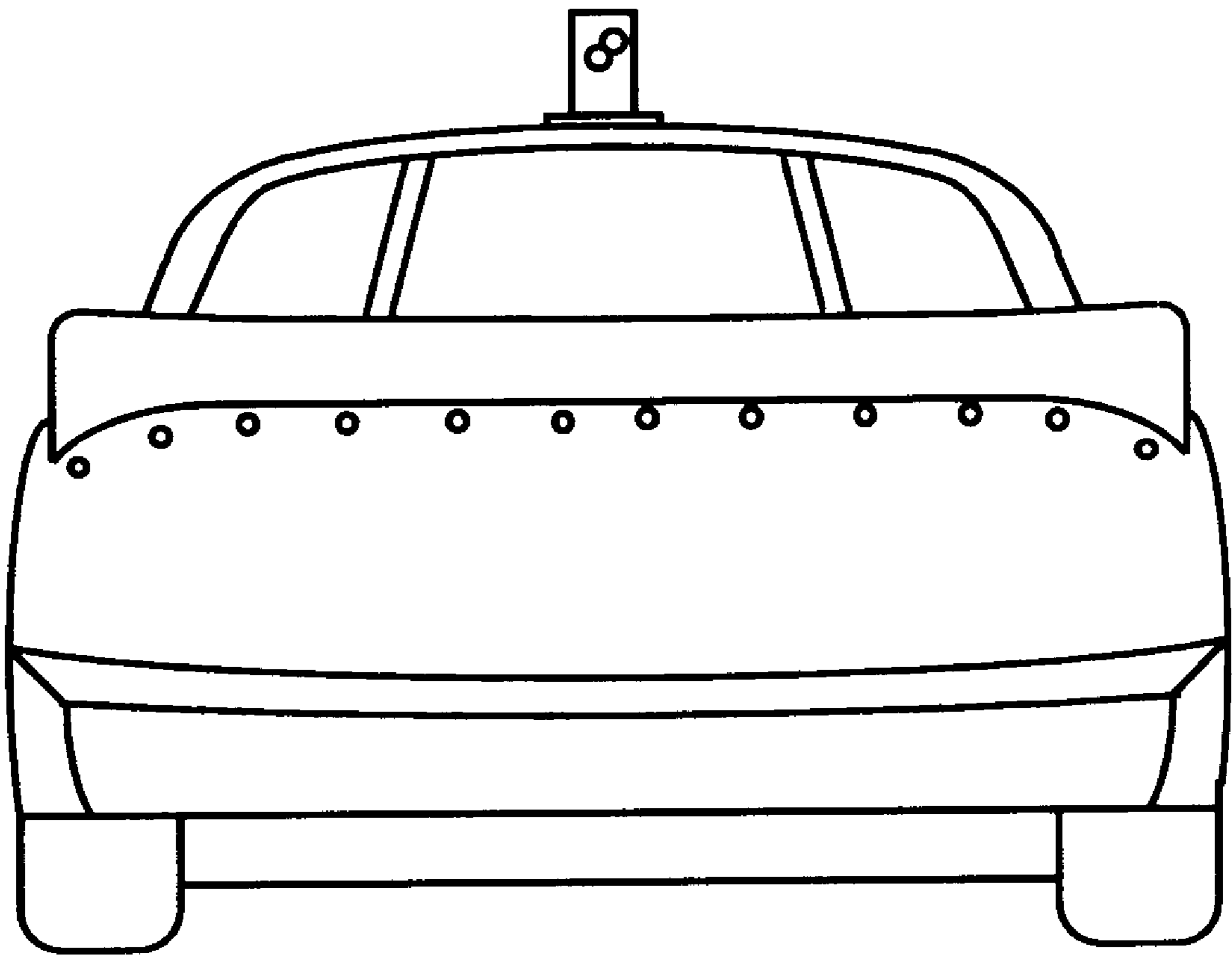

FIG. 5

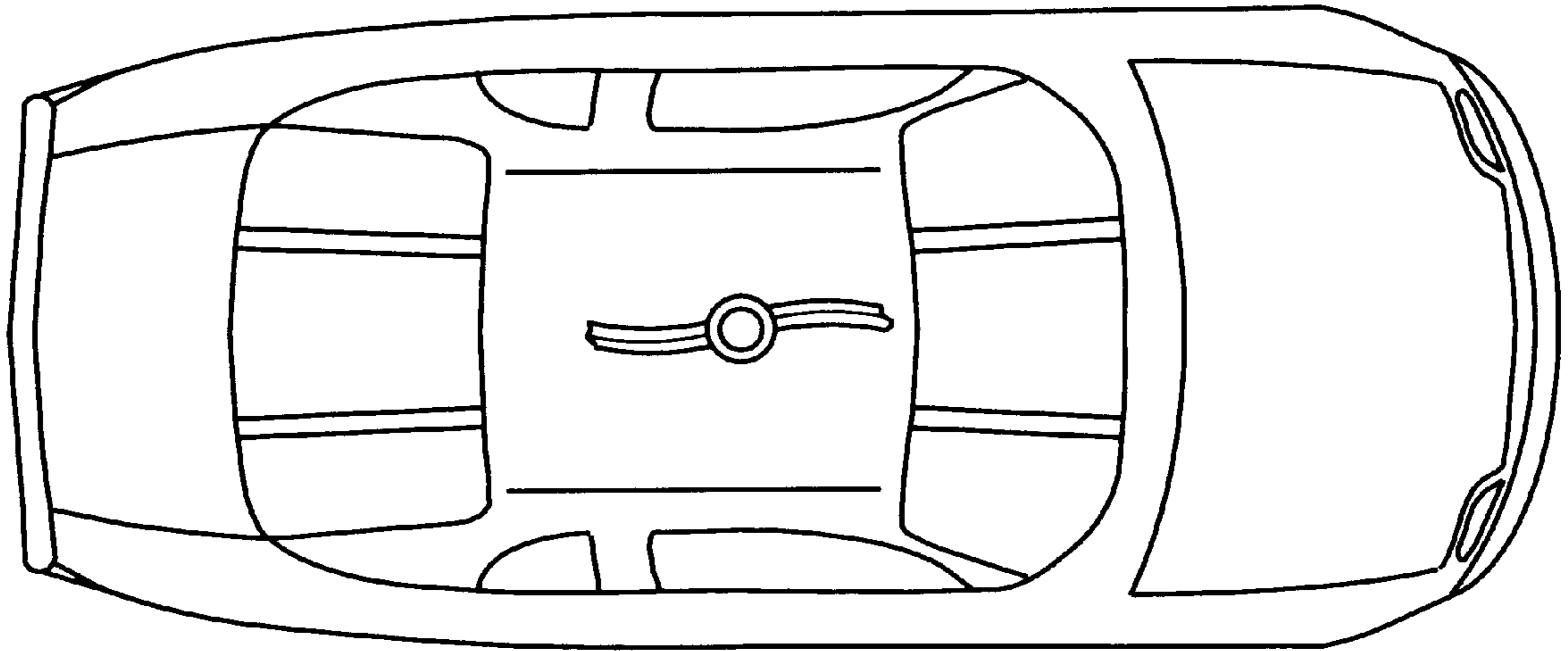

FIG. 6

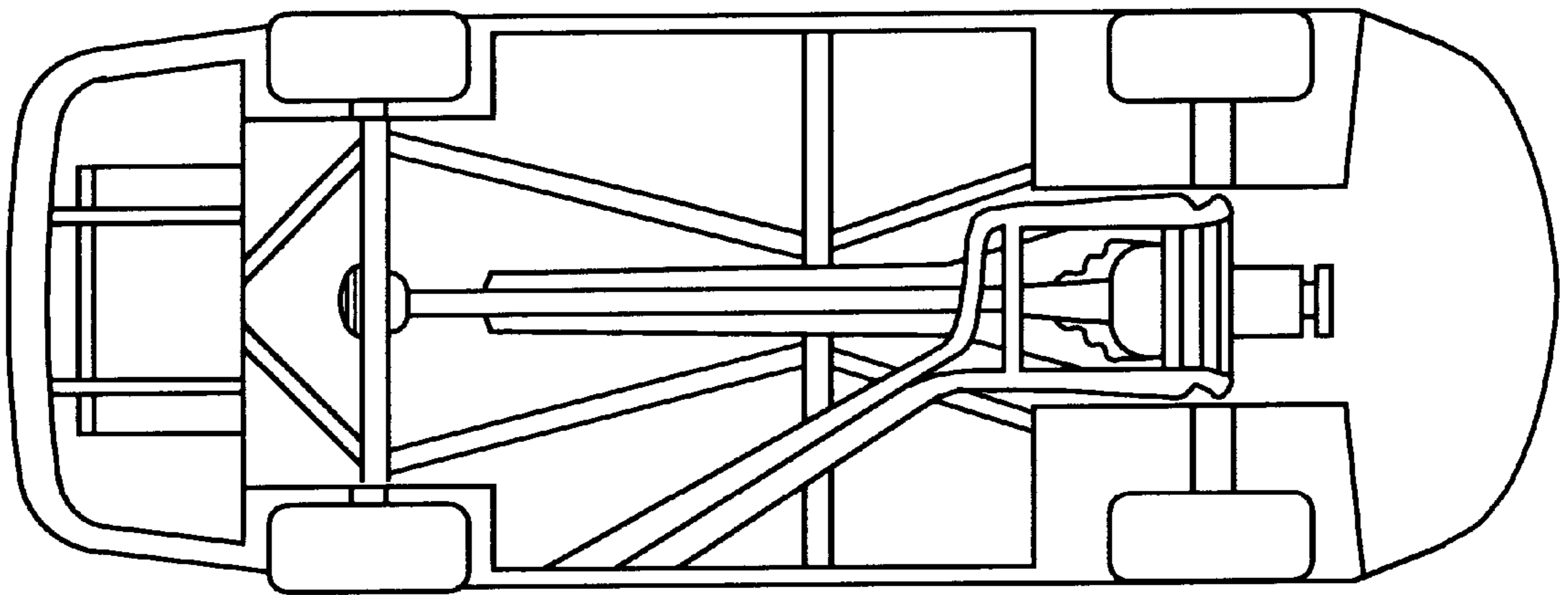

FIG. 7

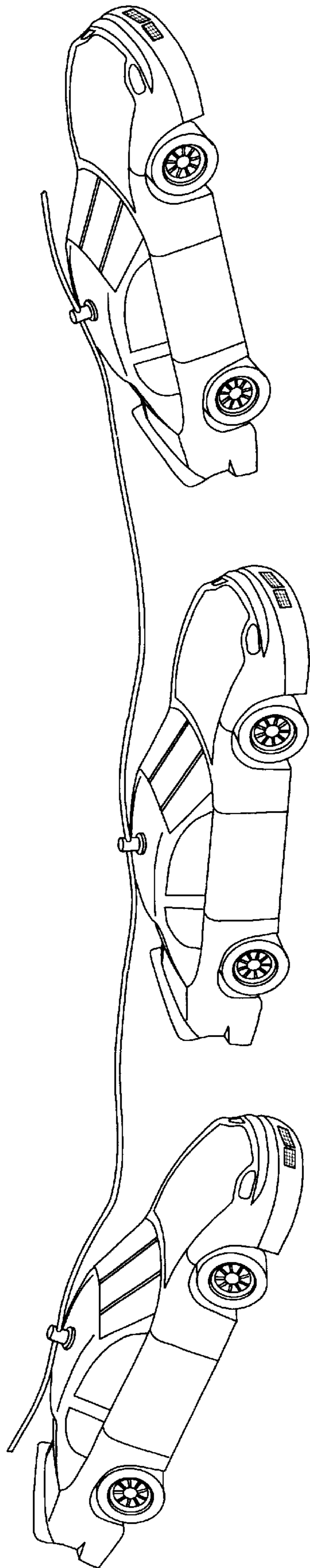

FIG. 8

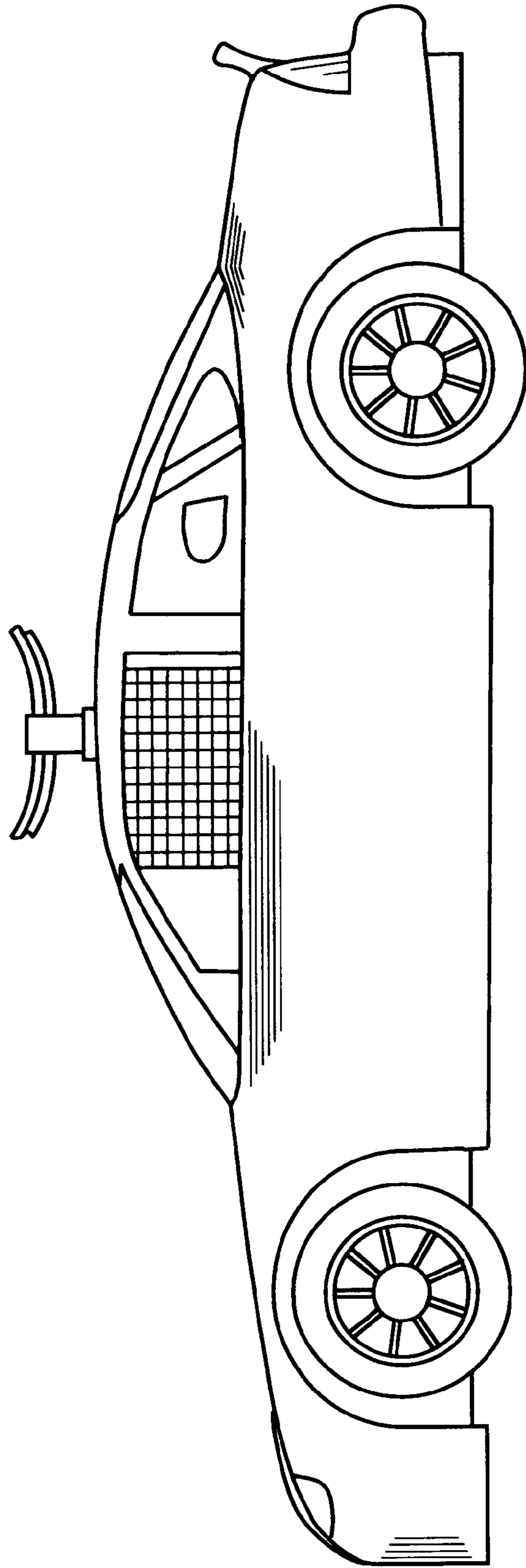

FIG. 9

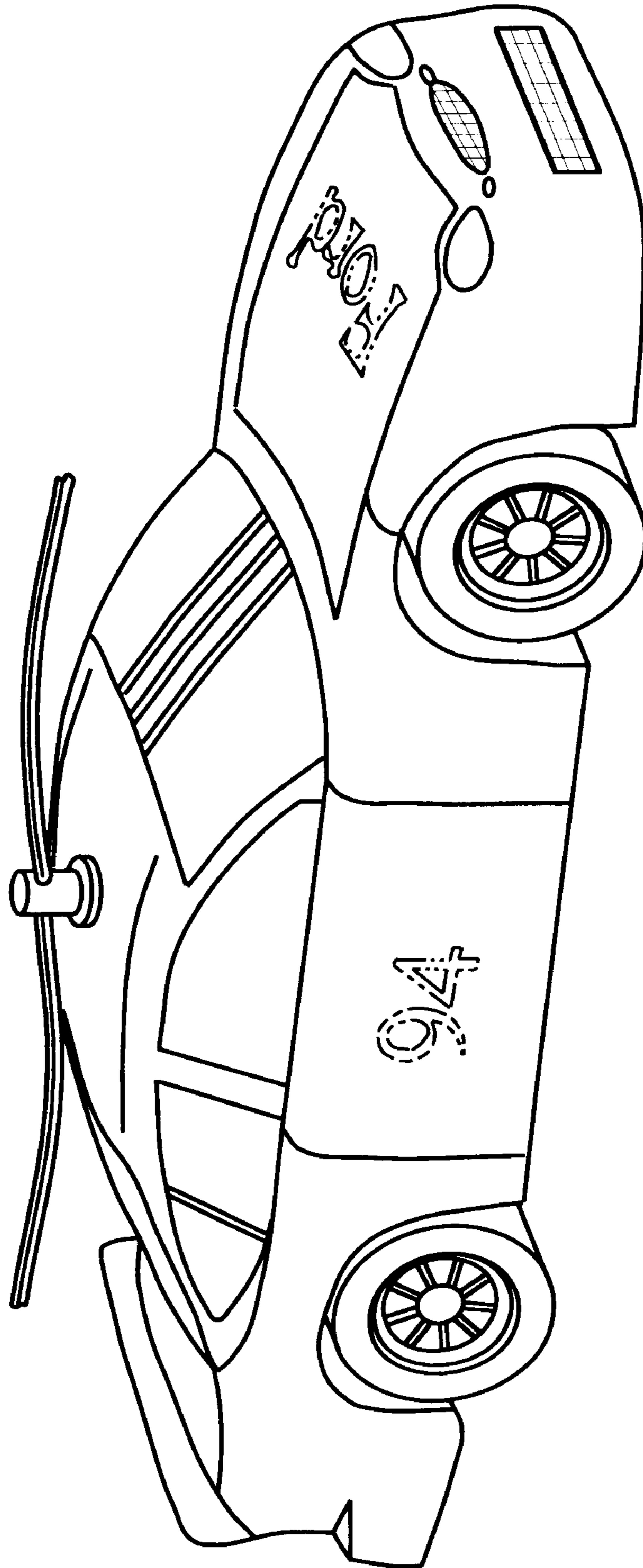

FIG. 10

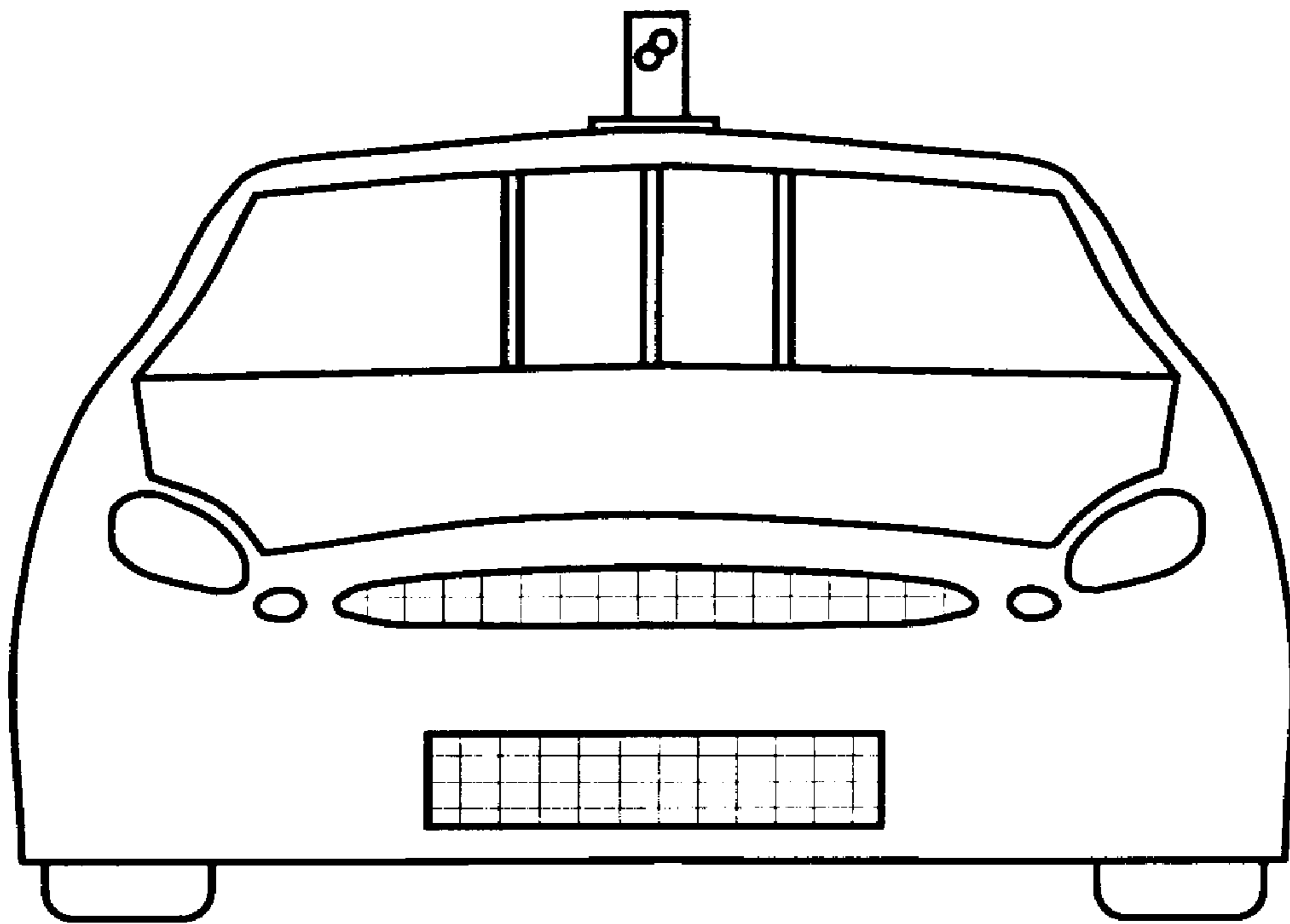

FIG. 11

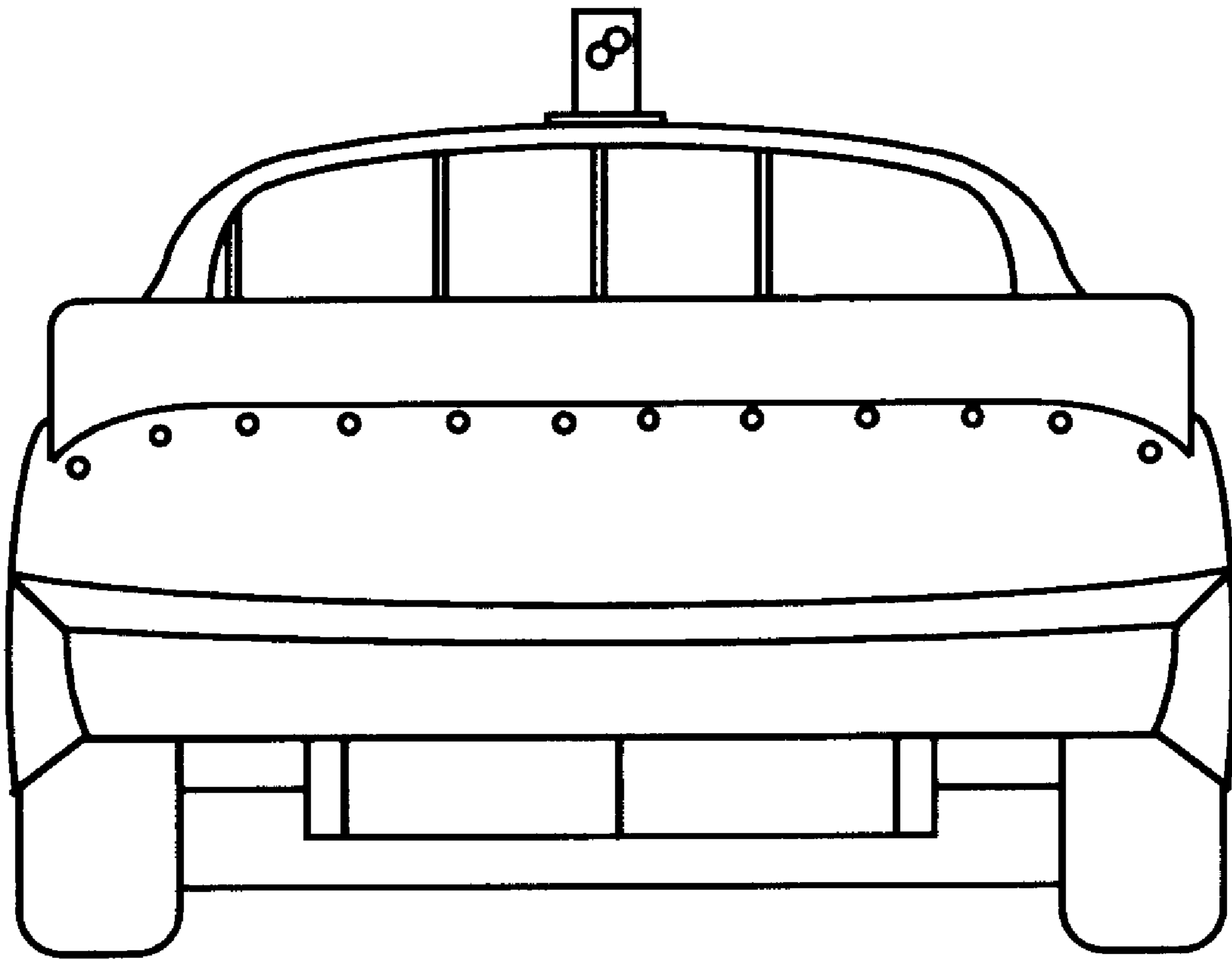

FIG. 12

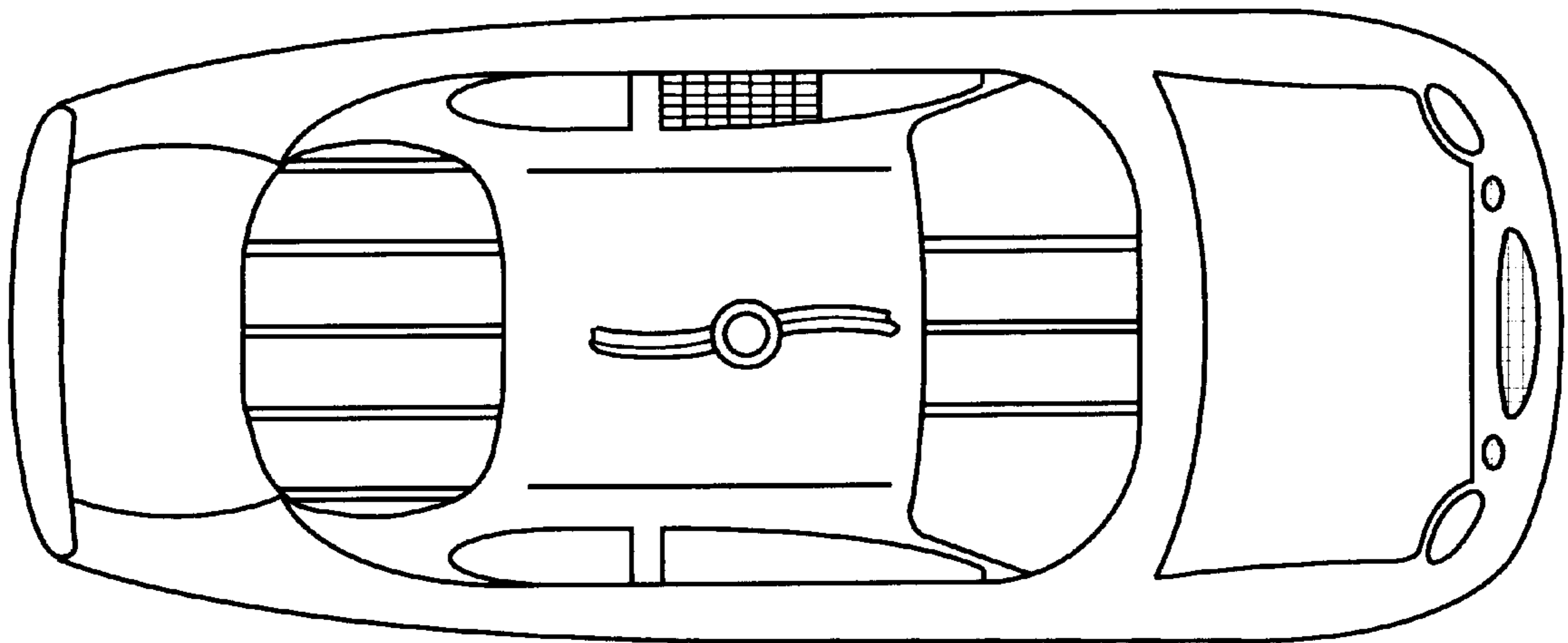

FIG. 13

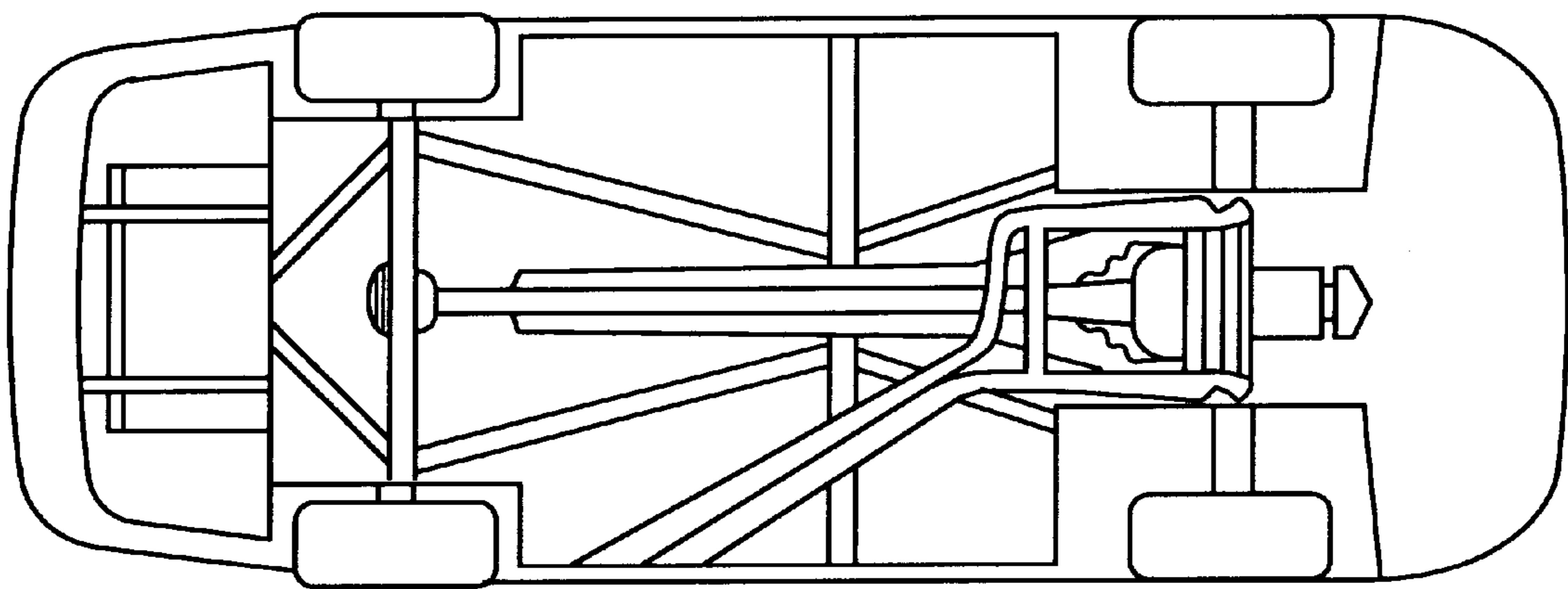

FIG. 14

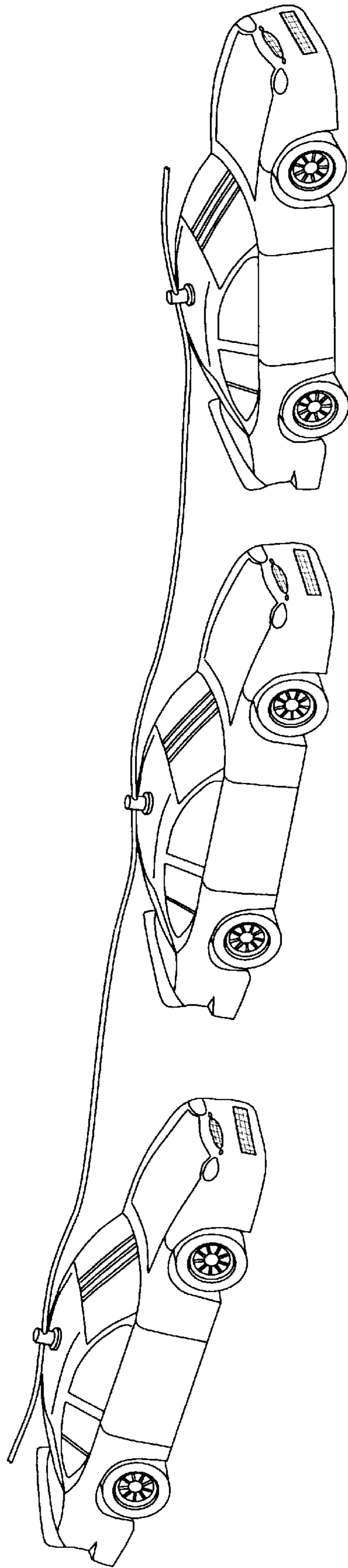

FIG. 15

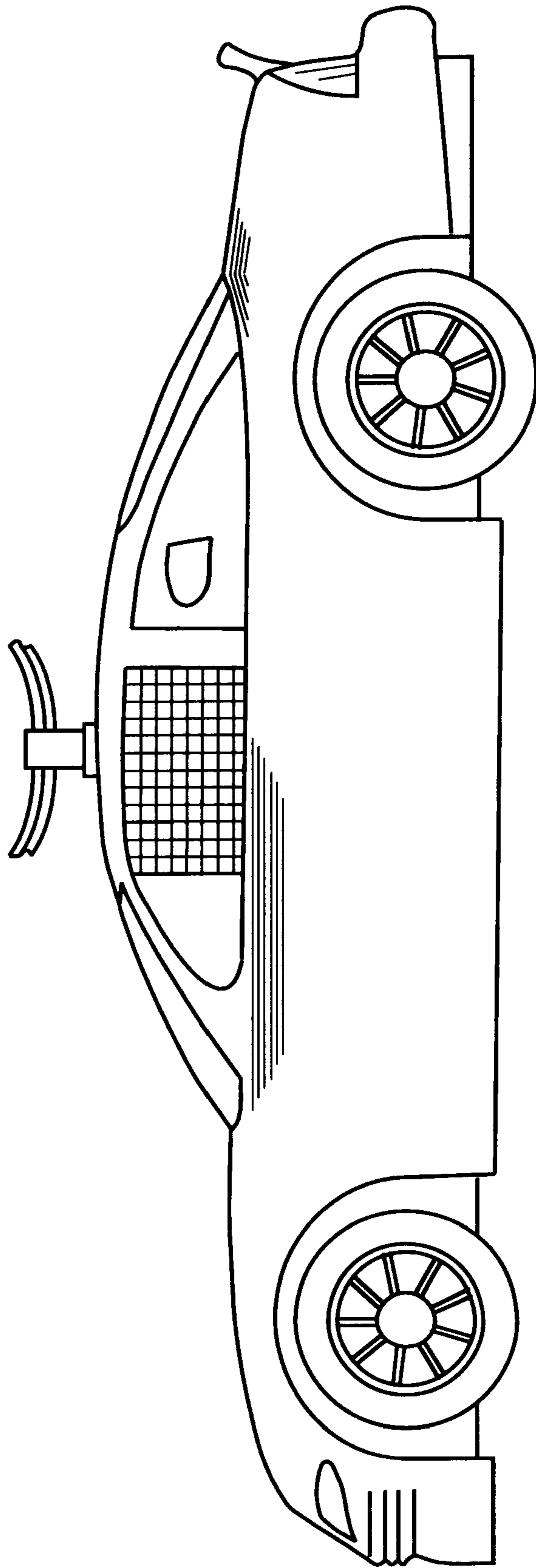

FIG. 16

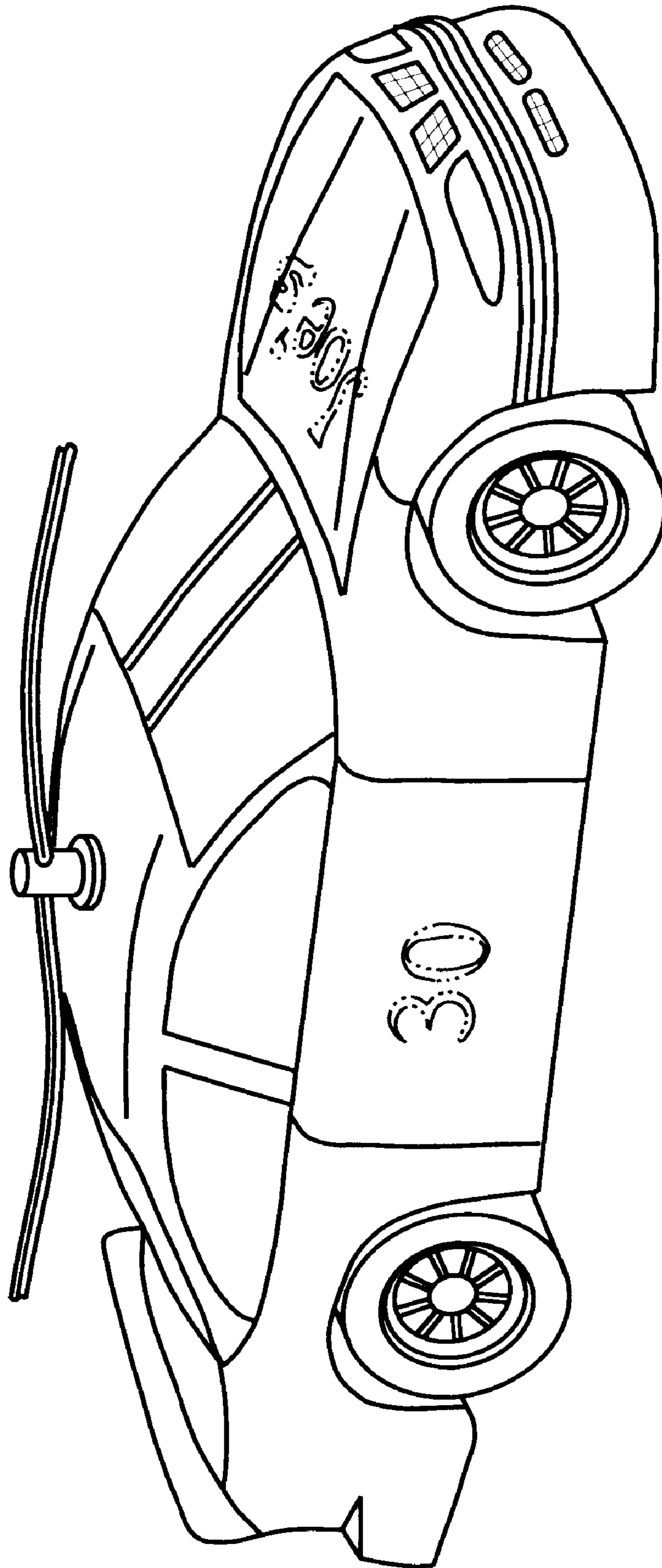

FIG. 17

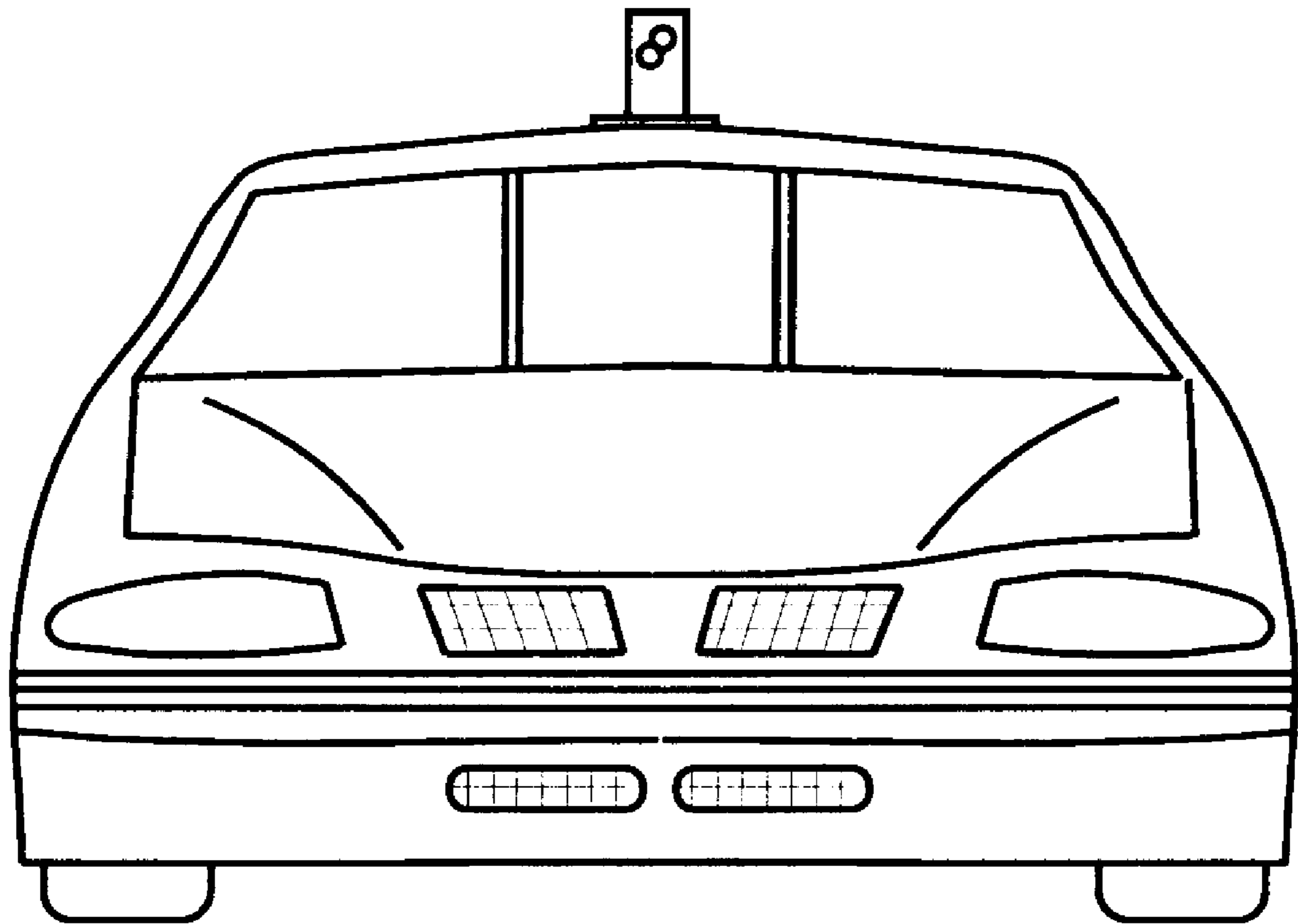

FIG. 18

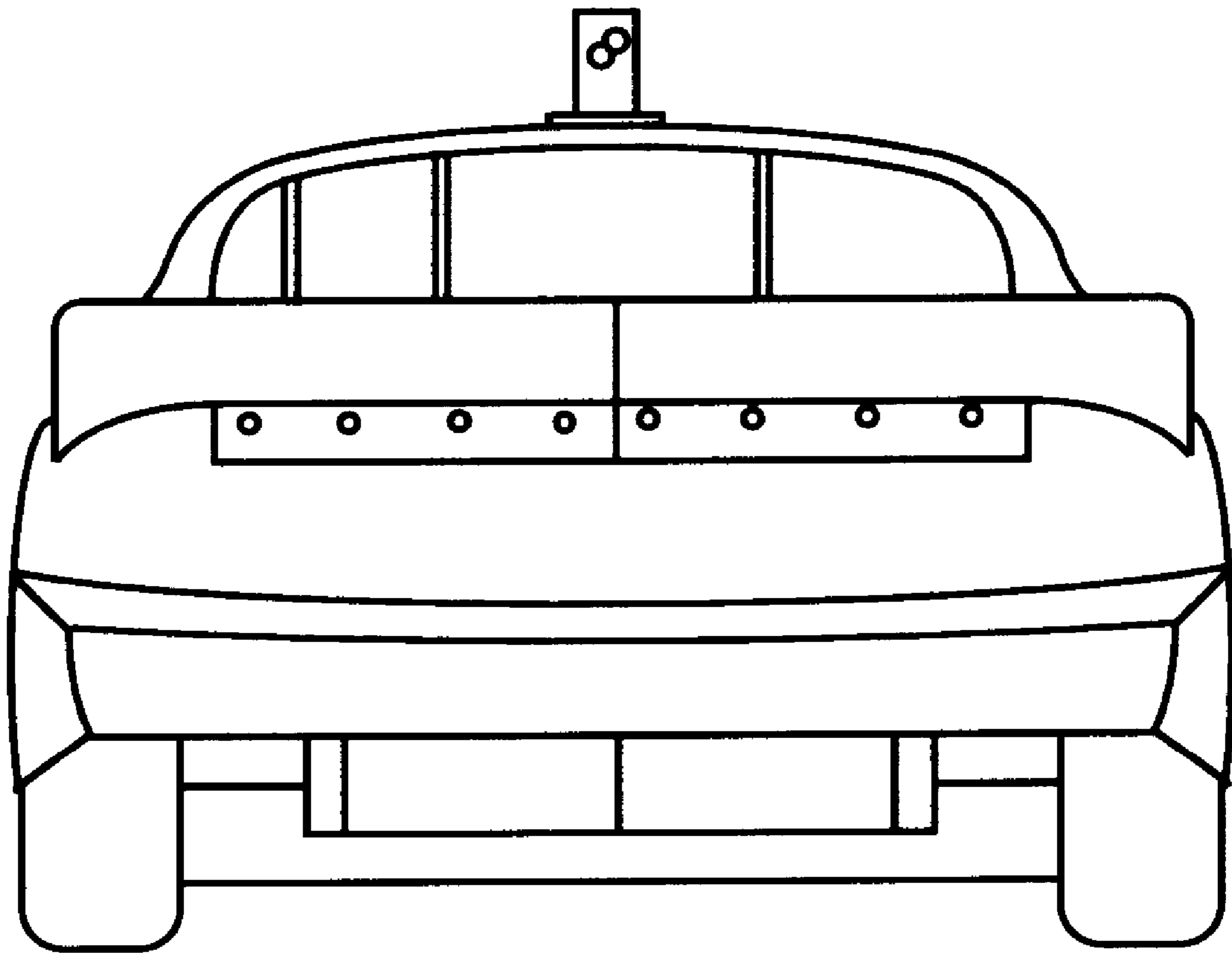

FIG. 19

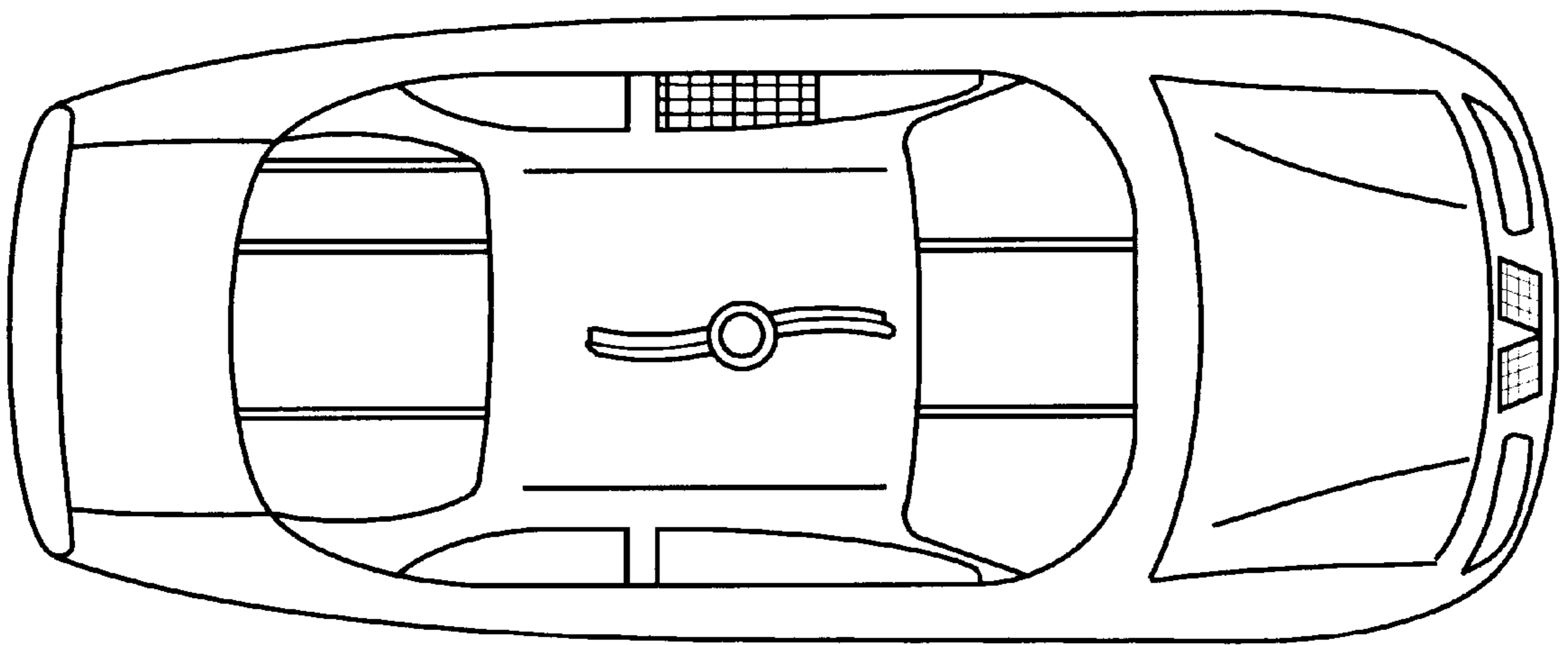

FIG. 20

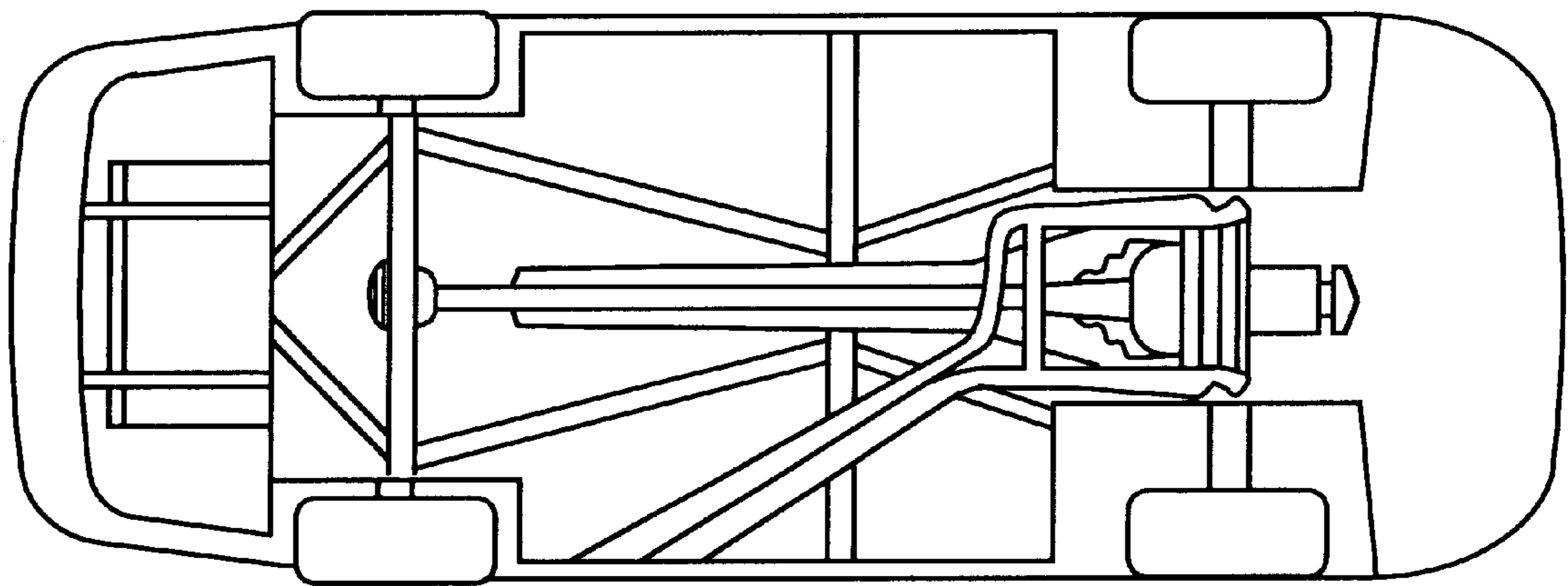

FIG. 21

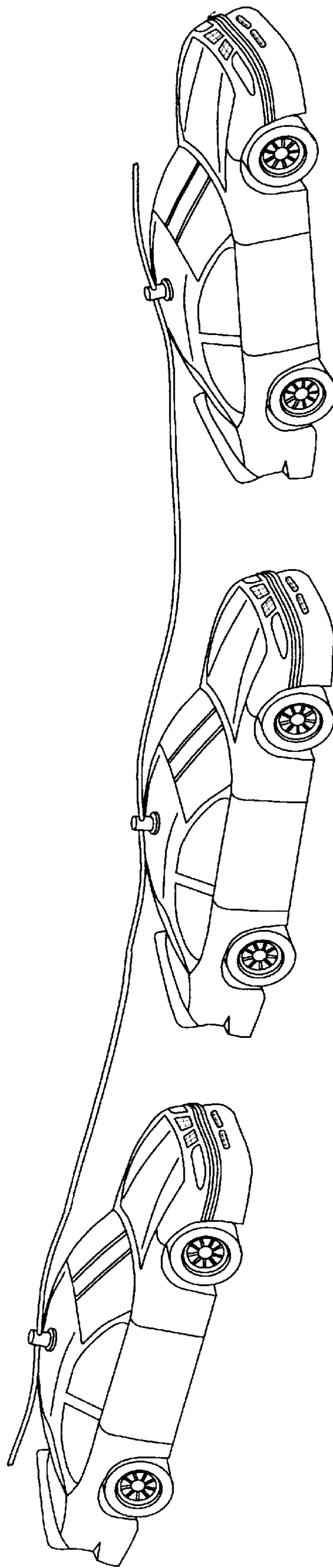

FIG. 22