



US00D435817S

(12) **United States Design Patent**  
**Lai**

(10) **Patent No.:** **US D435,817 S**

(45) **Date of Patent:** **\*\* Jan. 2, 2001**

(54) **REAR AIR GUIDE**

(75) Inventor: **Pink Lai**, Königsbach-Stein (DE)

(73) Assignee: **Dr. Ing. h.c.F. Porsche**  
**Aktiengesellschaft**, Stuttgart (DE)

(\*\*) Term: **14 Years**

(21) Appl. No.: **29/117,748**

(22) Filed: **Feb. 1, 2000**

(30) **Foreign Application Priority Data**

Aug. 12, 1999 (DE) ..... 4 99 07 253

(51) **LOC (7) Cl.** ..... **12-16**

(52) **U.S. Cl.** ..... **D12/181**

(58) **Field of Search** ..... D12/181, 191,  
D12/91, 196, 400; 160/133, DIG. 1; 280/848;  
296/82, 180.1, 180.2, 208, 180.3-180.5

(56) **References Cited**

**U.S. PATENT DOCUMENTS**

- D. 290,453 \* 6/1987 Konen et al. .... D12/181
- D. 290,454 \* 6/1987 Menking et al. .... D12/181
- D. 291,978 \* 9/1987 Parr et al. .... D12/181
- D. 322,238 \* 12/1991 Kanai ..... D12/181
- D. 373,558 \* 9/1996 Saleen ..... D12/181
- D. 376,341 \* 12/1996 Kovach et al. .... D12/181
- D. 377,160 \* 1/1997 Murkett ..... D12/181
- D. 377,331 \* 1/1997 Murkett ..... D12/181
- D. 401,199 \* 11/1998 Kovach et al. .... D12/181
- D. 403,638 \* 1/1999 Boniface et al. .... D12/181
- D. 409,963 \* 5/1999 Mobius et al. .... D12/181

- D. 420,314 \* 2/2000 Kulla et al. .... D12/181
- D. 422,544 \* 4/2000 Carlson et al. .... D12/181
- D. 423,430 \* 4/2000 Minh ..... D12/181
- 5,934,740 \* 8/1999 Moebius et al. .... 296/180.1

\* cited by examiner

*Primary Examiner*—Stacia Cadmus

(74) *Attorney, Agent, or Firm*—Evenson, McKeown,  
Edwards & Lenahan, P.L.L.C.

(57) **CLAIM**

The ornamental design for a rear air guide, as shown and described.

**DESCRIPTION**

FIG. 1 is a front view of a rear air guide, showing my new design;  
 FIG. 2 is a right side view thereof;  
 FIG. 3 is a left side view thereof;  
 FIG. 4 is a left side perspective view thereof;  
 FIG. 5 is a right side perspective view thereof;  
 FIG. 6 is a front view of the rear air guide of FIG. 1, shown in closed position;  
 FIG. 7 is a left side view of the rear air guide of FIG. 6;  
 FIG. 8 is a right side view of the rear air guide of FIG. 6;  
 FIG. 9 is a left side perspective view of the rear air guide of FIG. 6; and,  
 FIG. 10 is a right side perspective view of the rear air guide of FIG. 6.

The dash lines show depict environment and are not part of the claimed design.

**1 Claim, 5 Drawing Sheets**

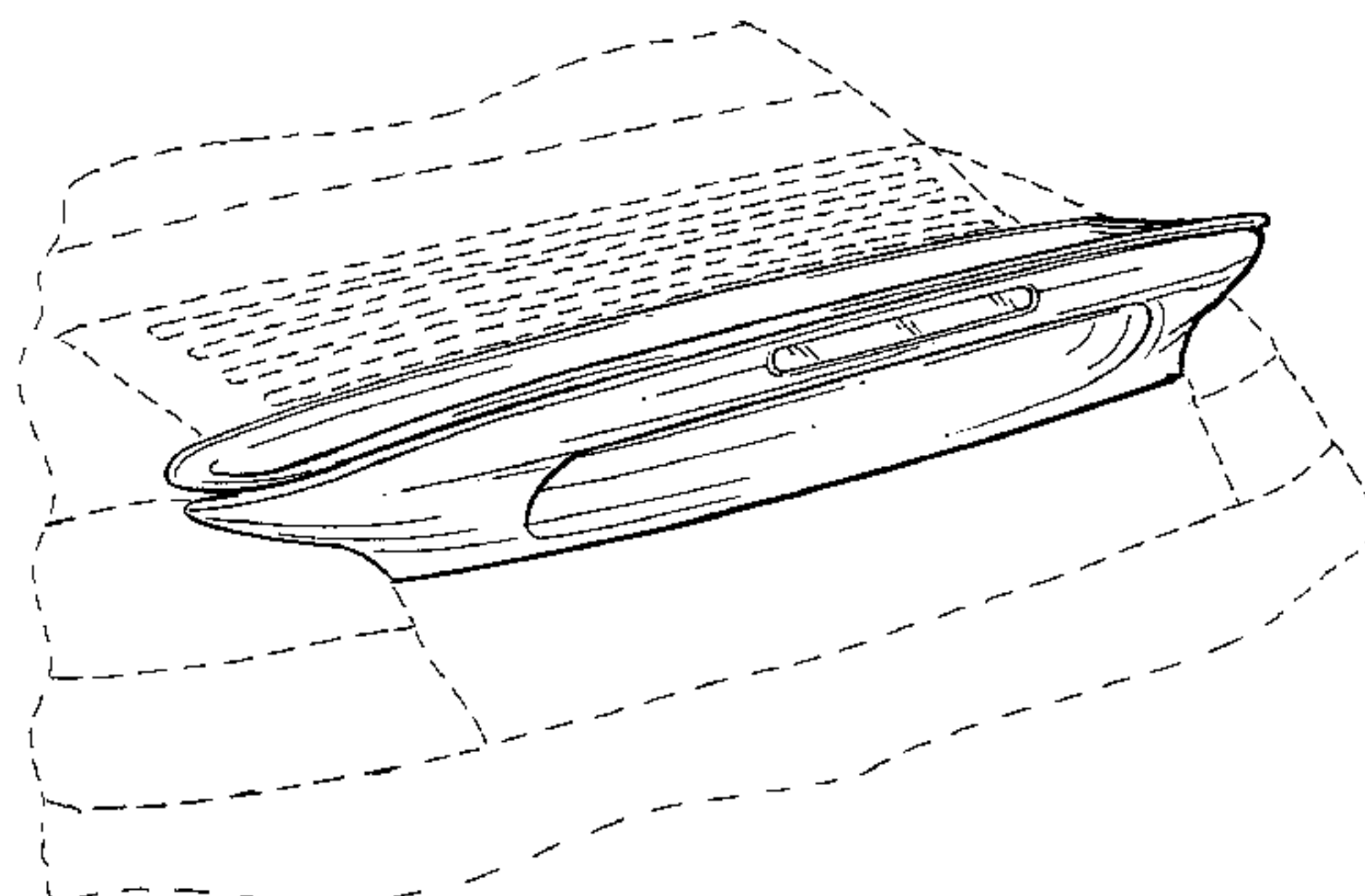
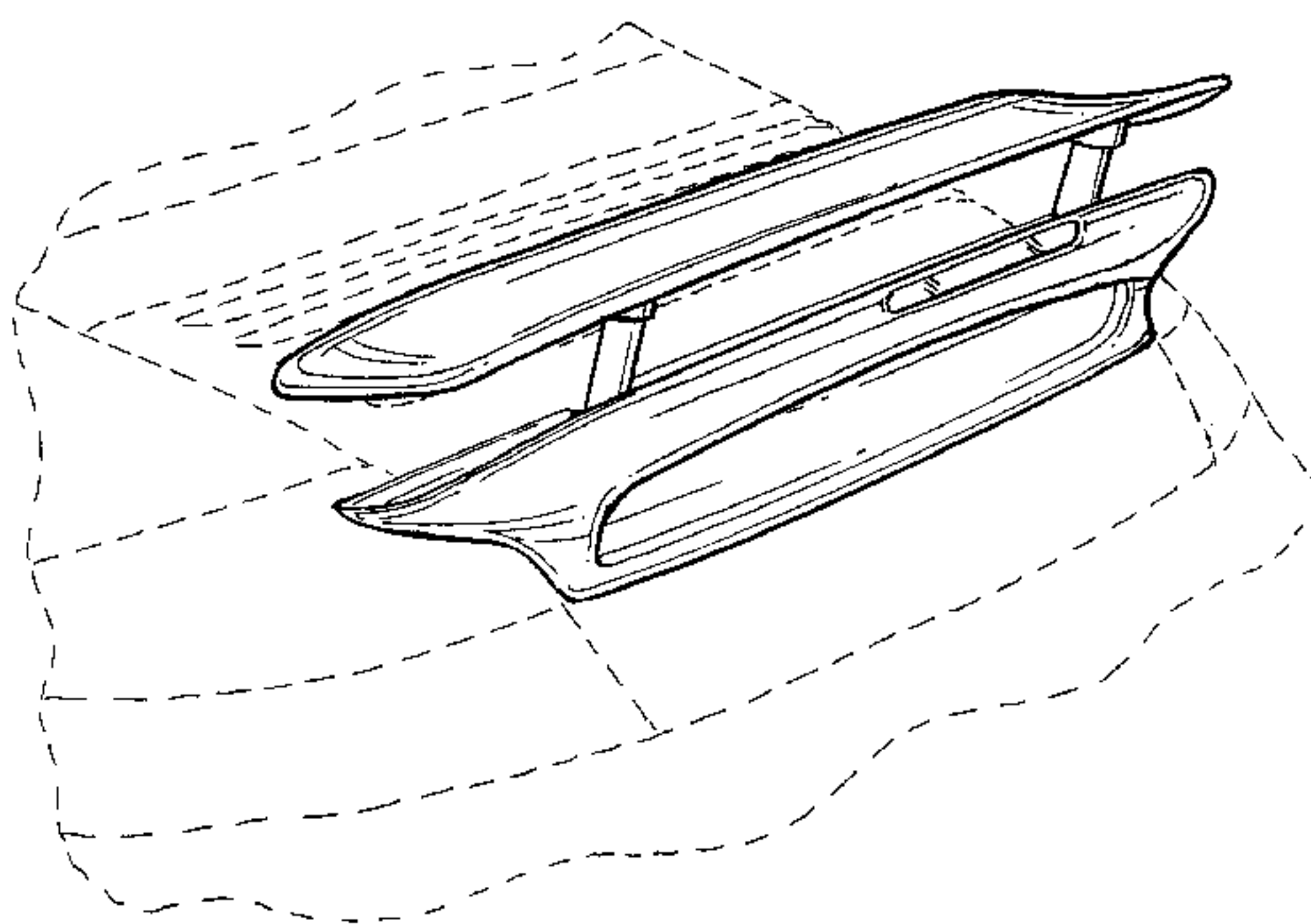

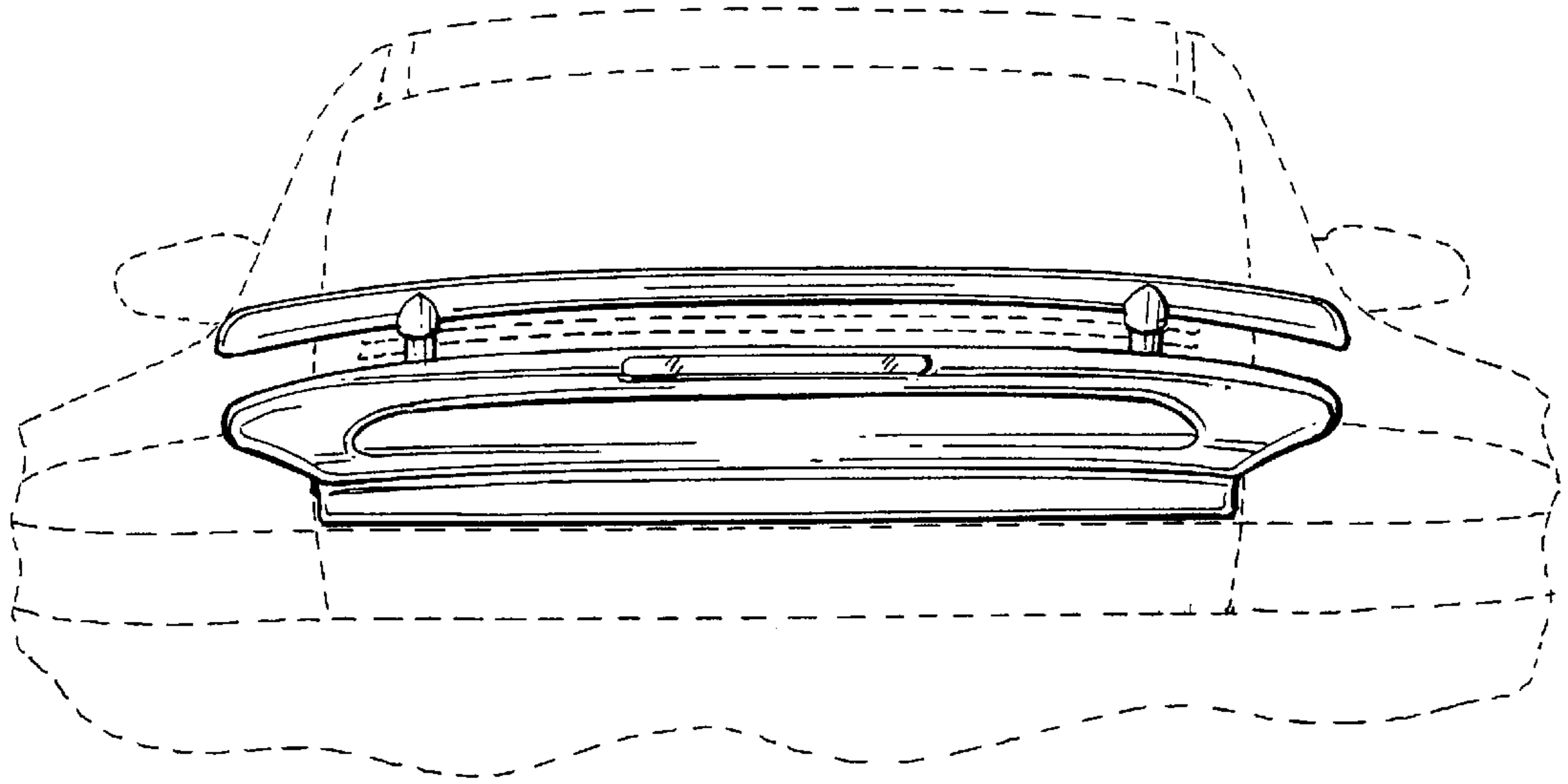

FIG. 1

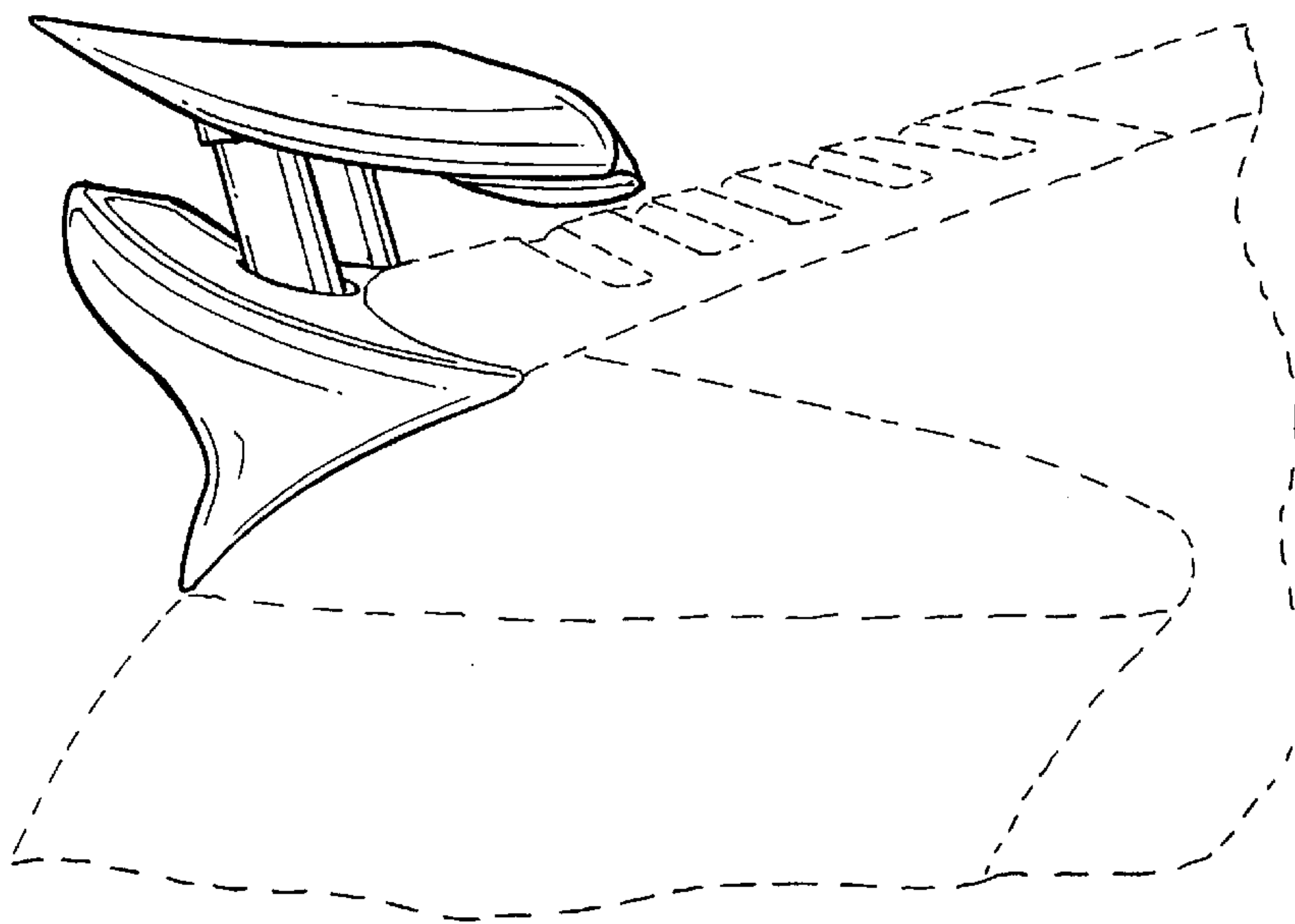

FIG. 2

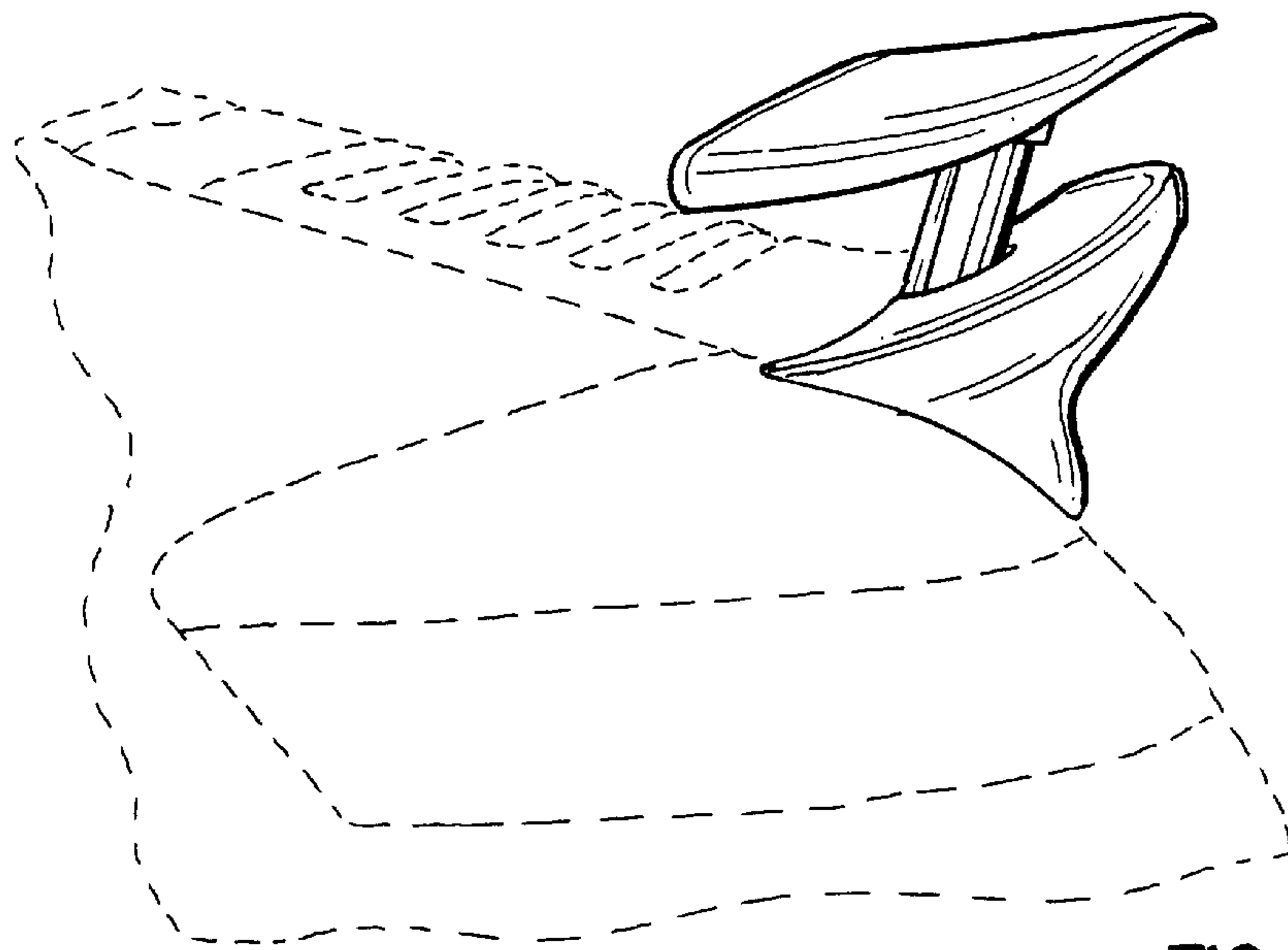

FIG. 3

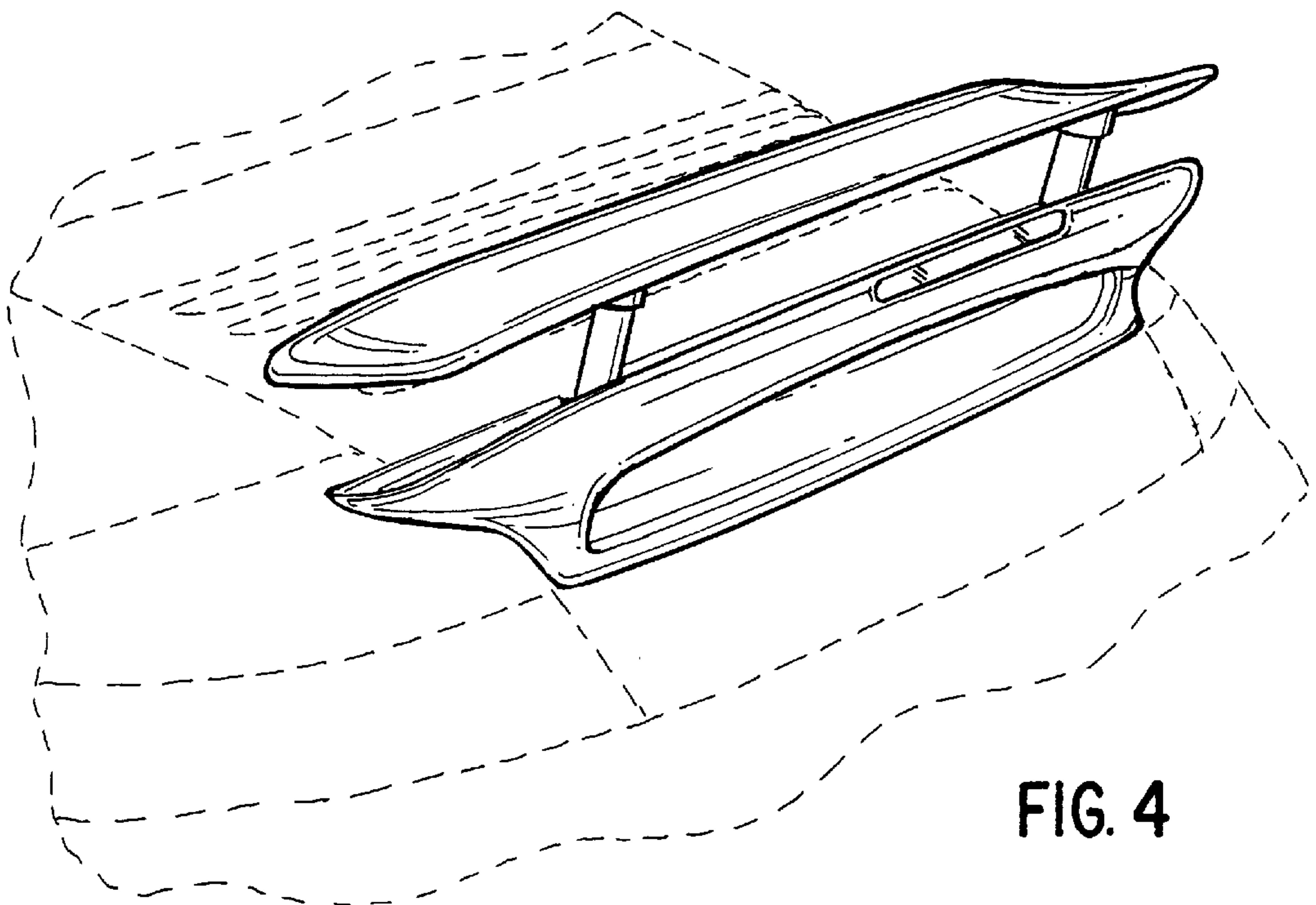

FIG. 4

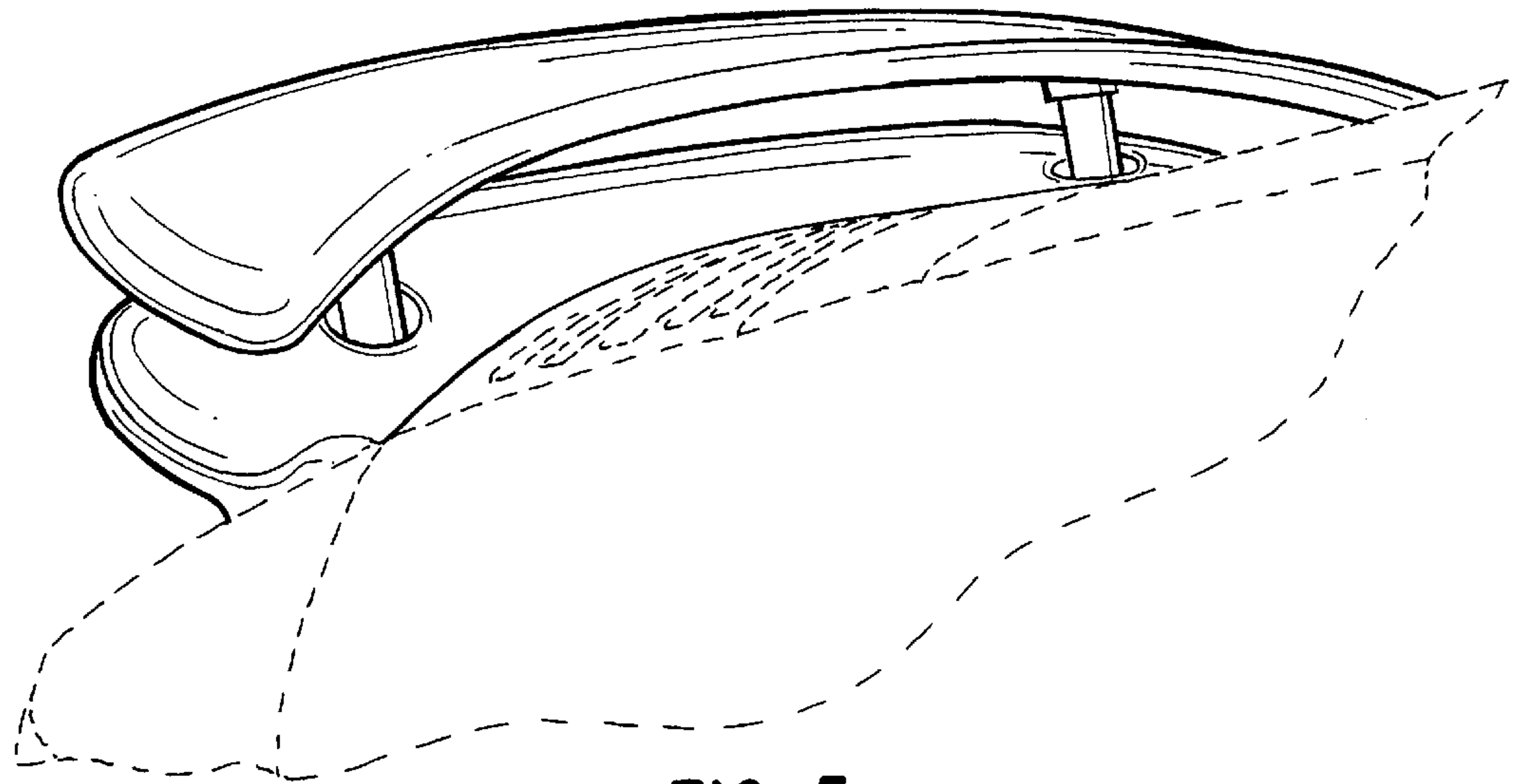

FIG. 5

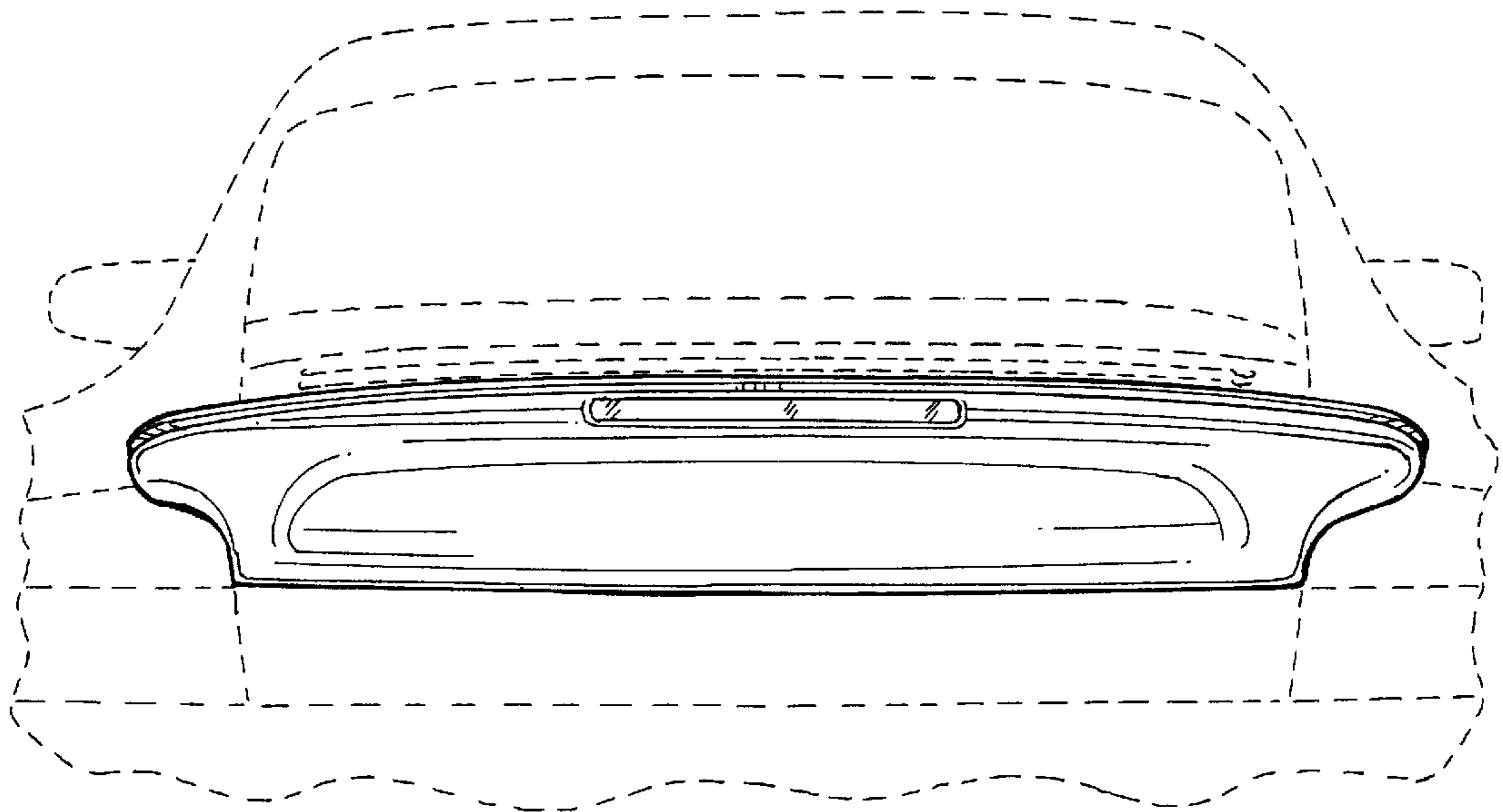

FIG. 6

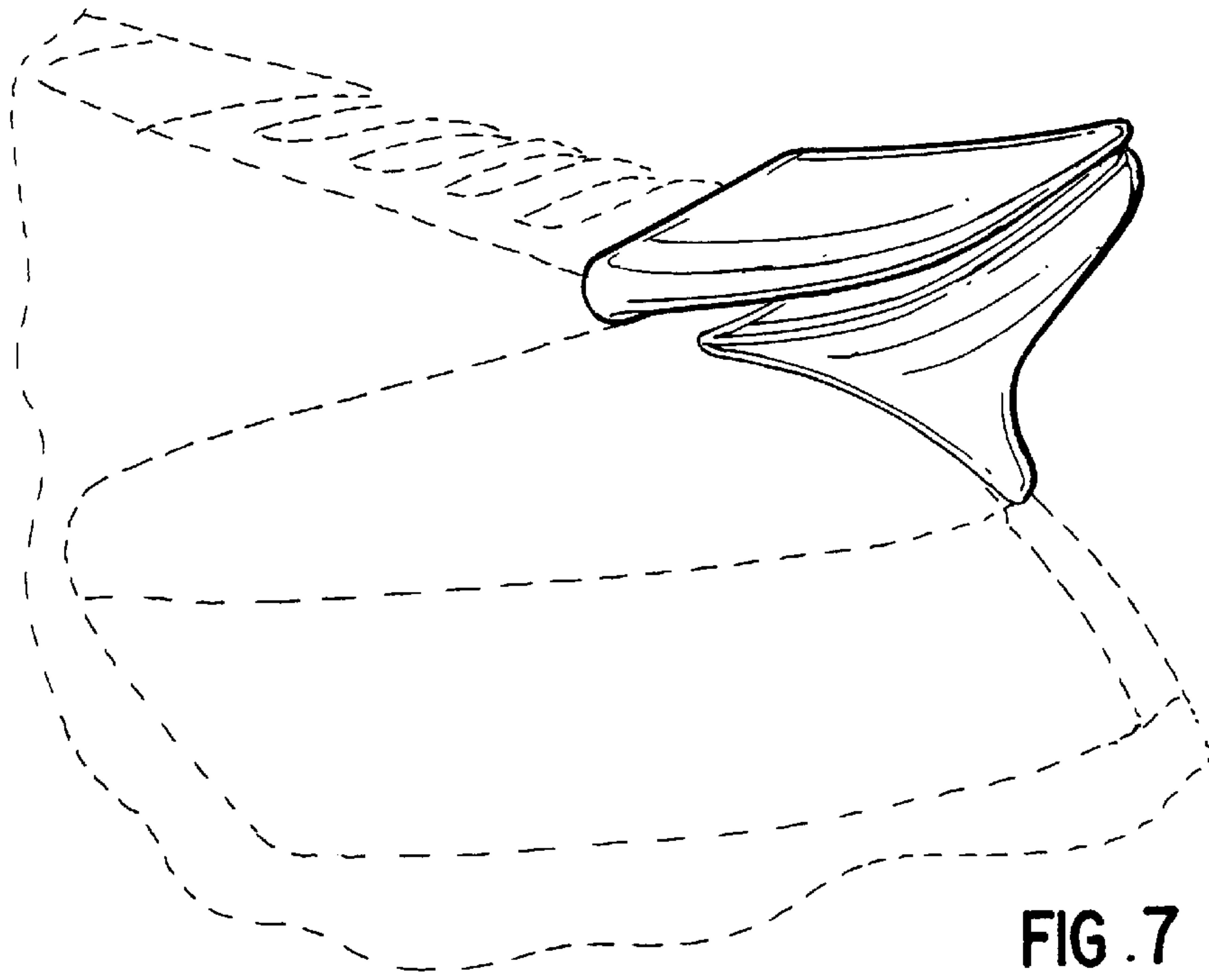

FIG. 7

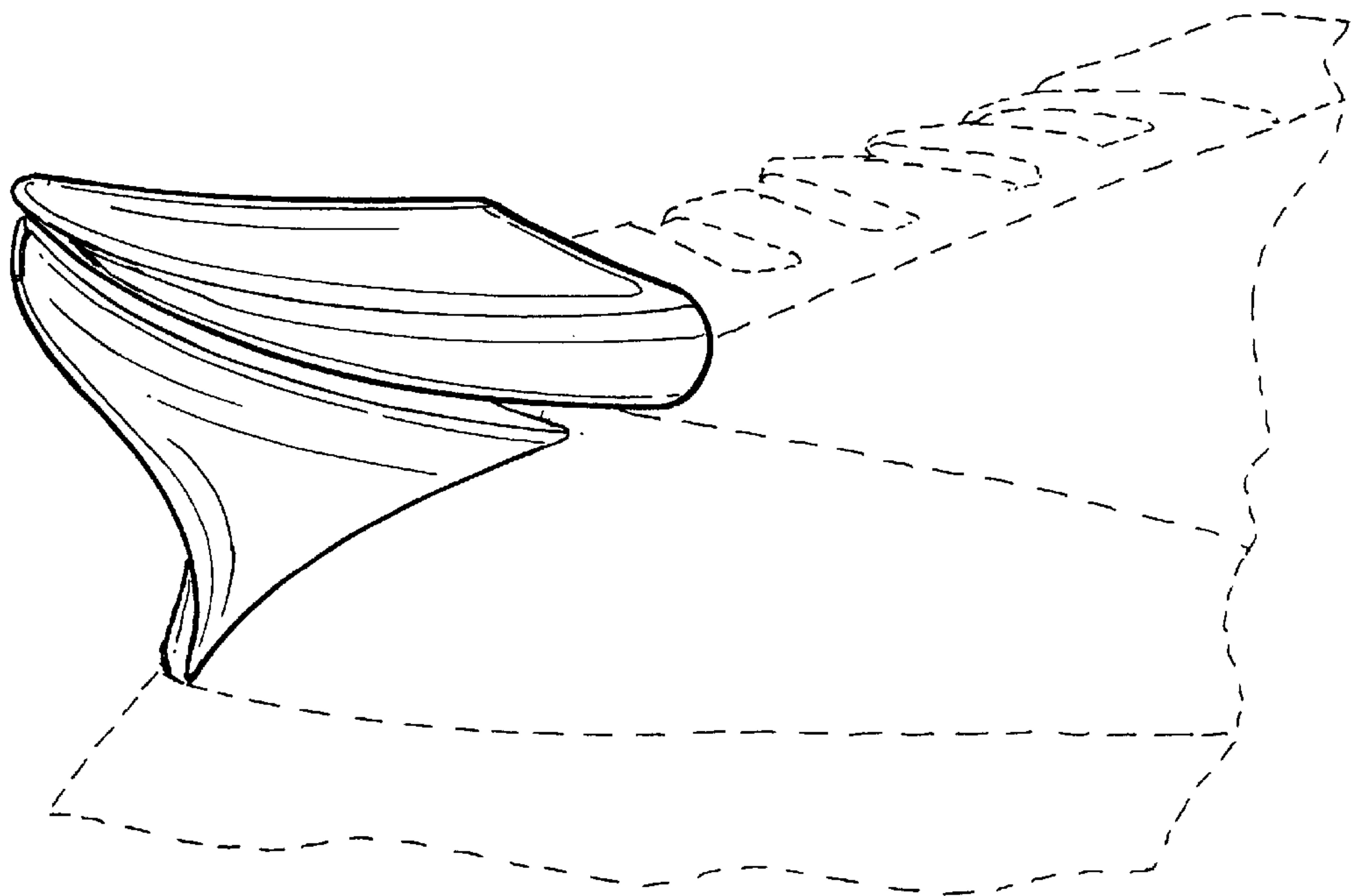

FIG. 8



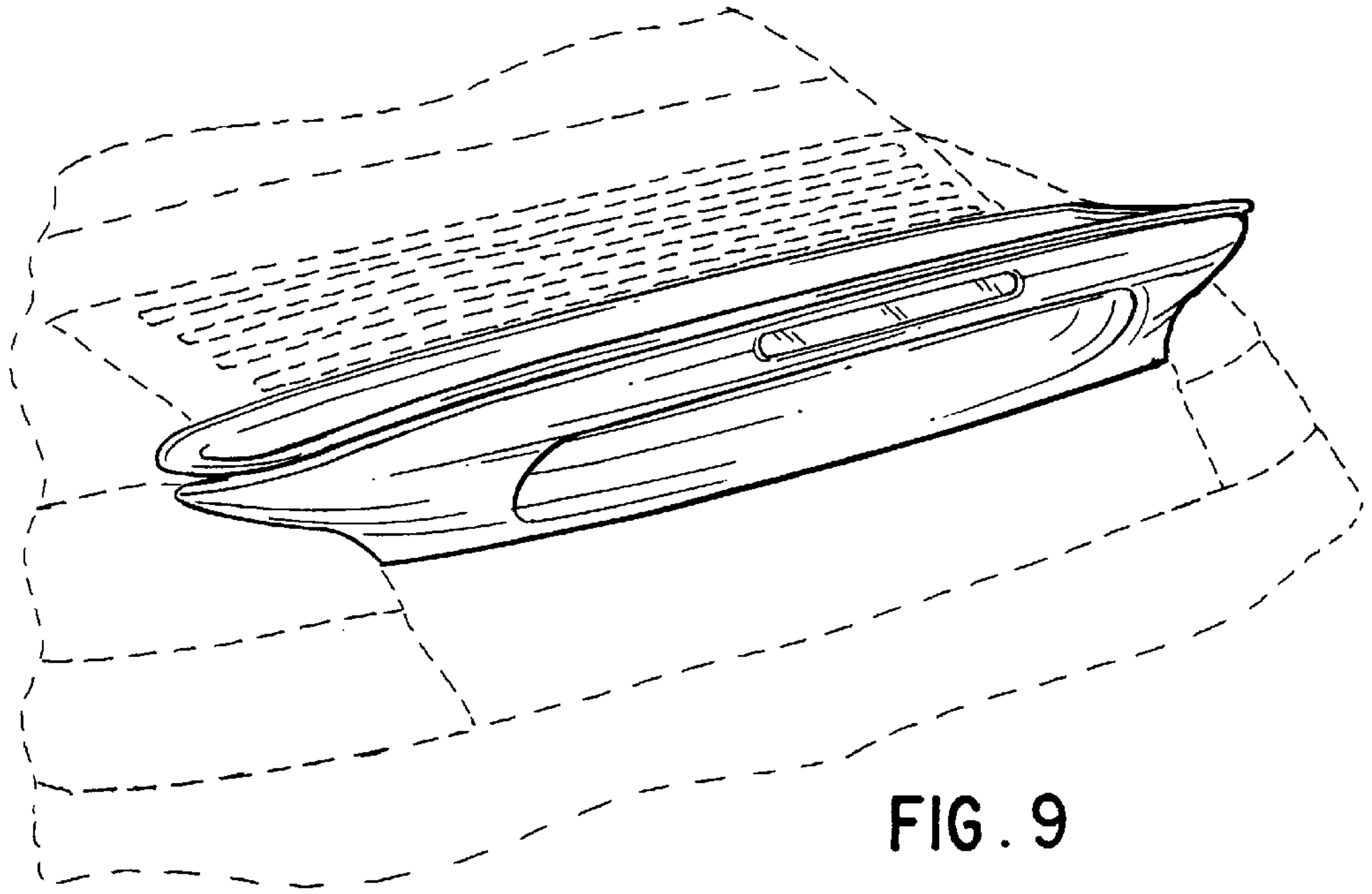

FIG. 9

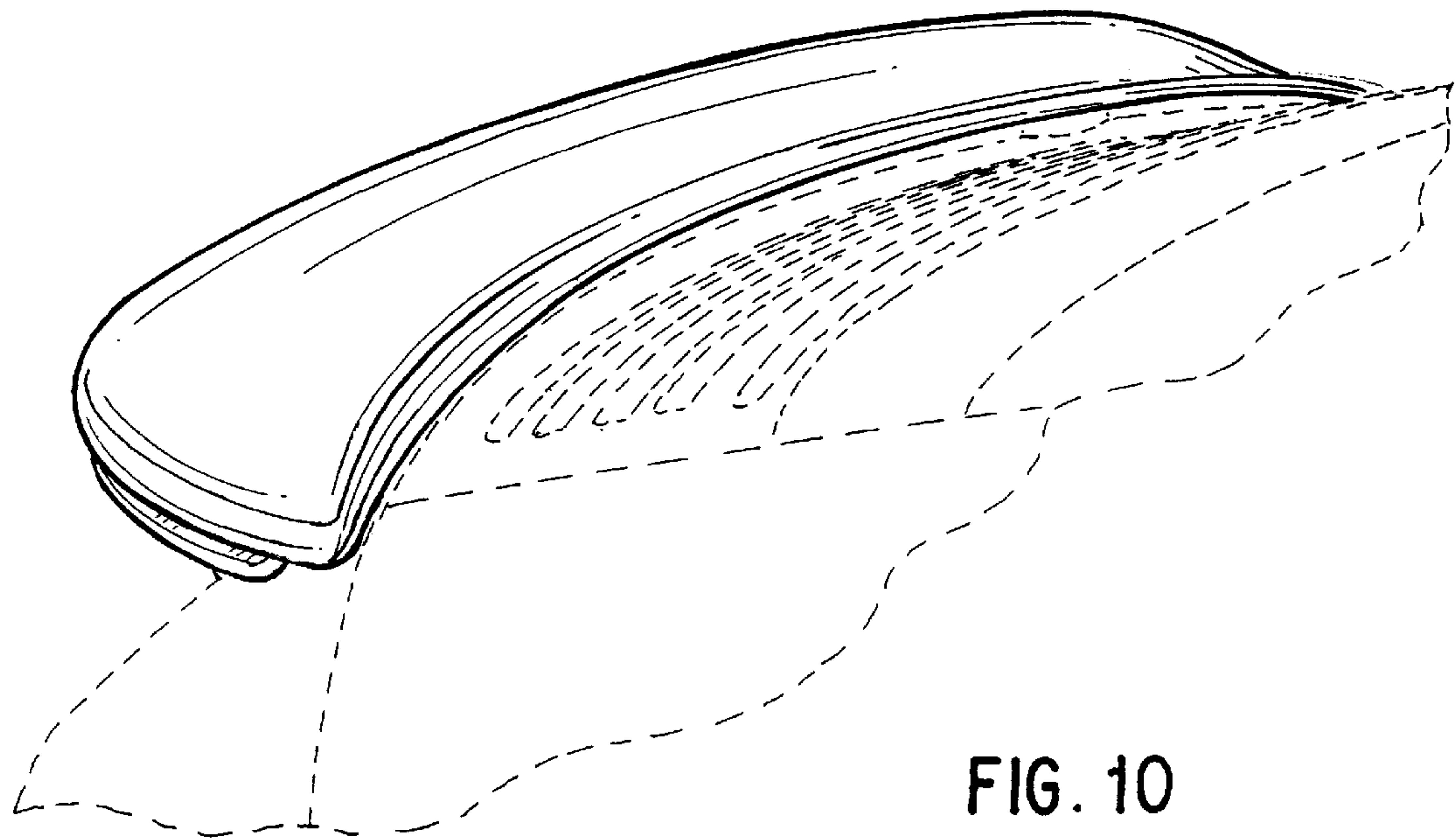

FIG. 10