



US00D435780S

(12) **United States Design Patent**
Tieu

(10) **Patent No.:** **US D435,780 S**

(45) **Date of Patent:** **** Jan. 2, 2001**

(54) **LATCH ASSEMBLY**

(75) **Inventor:** **Loc B. Tieu**, Exton, PA (US)

(73) **Assignee:** **Southco**, Concordville, PA (US)

(**) **Term:** **14 Years**

(21) **Appl. No.:** **29/094,107**

(22) **Filed:** **Sep. 25, 1998**

(51) **LOC (7) Cl.** **08-07**

(52) **U.S. Cl.** **D8/331; D8/336**

(58) **Field of Search** **D8/330, 331, 300, D8/301, 302, 310, 333, 336, 341; 292/336.3, 95, 102, 103, 110, 113, 111; 16/420, 446**

(56) **References Cited**

U.S. PATENT DOCUMENTS

121,168	*	11/1871	Hannan	16/446
D. 276,888	*	12/1984	Jaeger	D8/330
D. 324,636	*	3/1992	Schlack et al.	D8/331
D. 413,056	*	8/1999	Sokurenko	D8/331
3,847,423	*	11/1974	Gley	292/113

4,522,436		6/1985	Hoen et al.	.	
4,890,869	*	1/1990	Langkamp	292/113
5,669,638		9/1997	Anderson et al.	.	

* cited by examiner

Primary Examiner—Susan J. Lucas
Assistant Examiner—Jennifer Rivard
(74) *Attorney, Agent, or Firm*—Paul & Paul

(57) **CLAIM**

The ornamental design for a latch assembly, as shown and described.

DESCRIPTION

FIG. 1 is perspective view of a latch assembly embodying my new design;
FIG. 2 is a top plan view thereof;
FIG. 3 is rear view thereof;
FIG. 4 is a left side elevational view thereof;
FIG. 5 is a front view thereof;
FIG. 6 is a right side elevational view thereof; and,
FIG. 7 is a bottom plan view thereof.

1 Claim, 1 Drawing Sheet

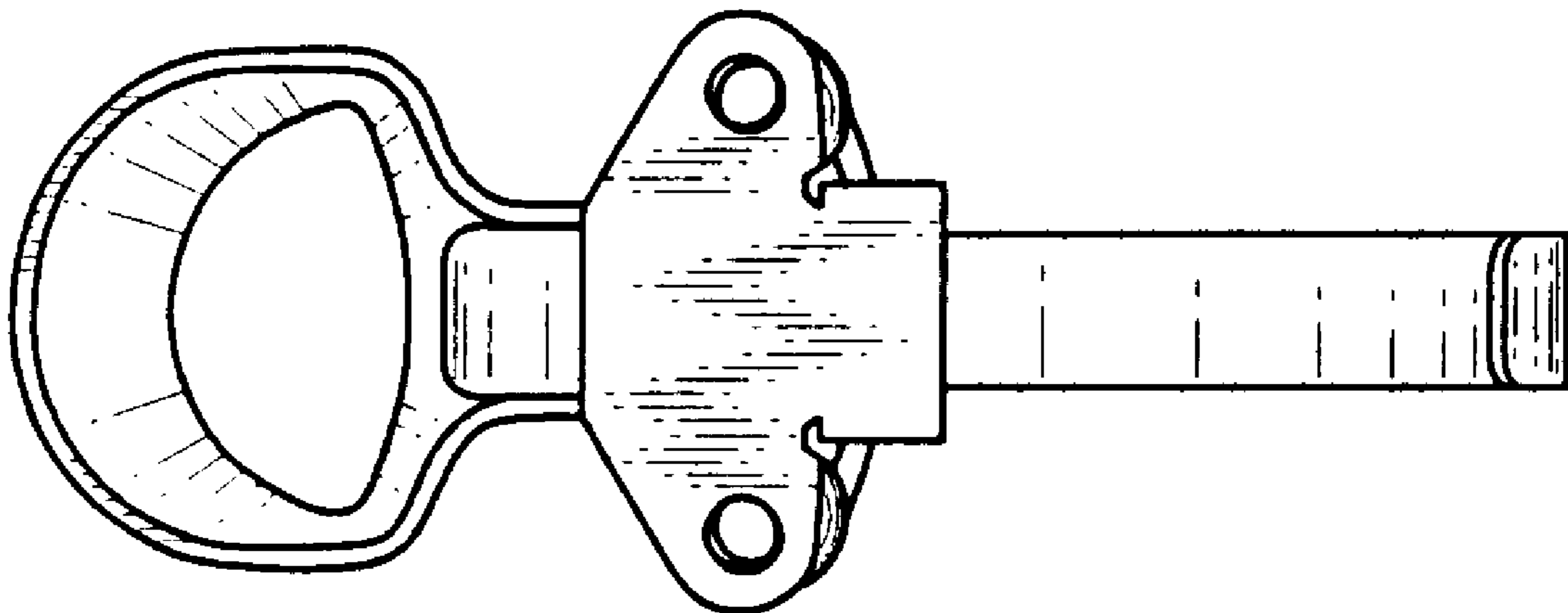

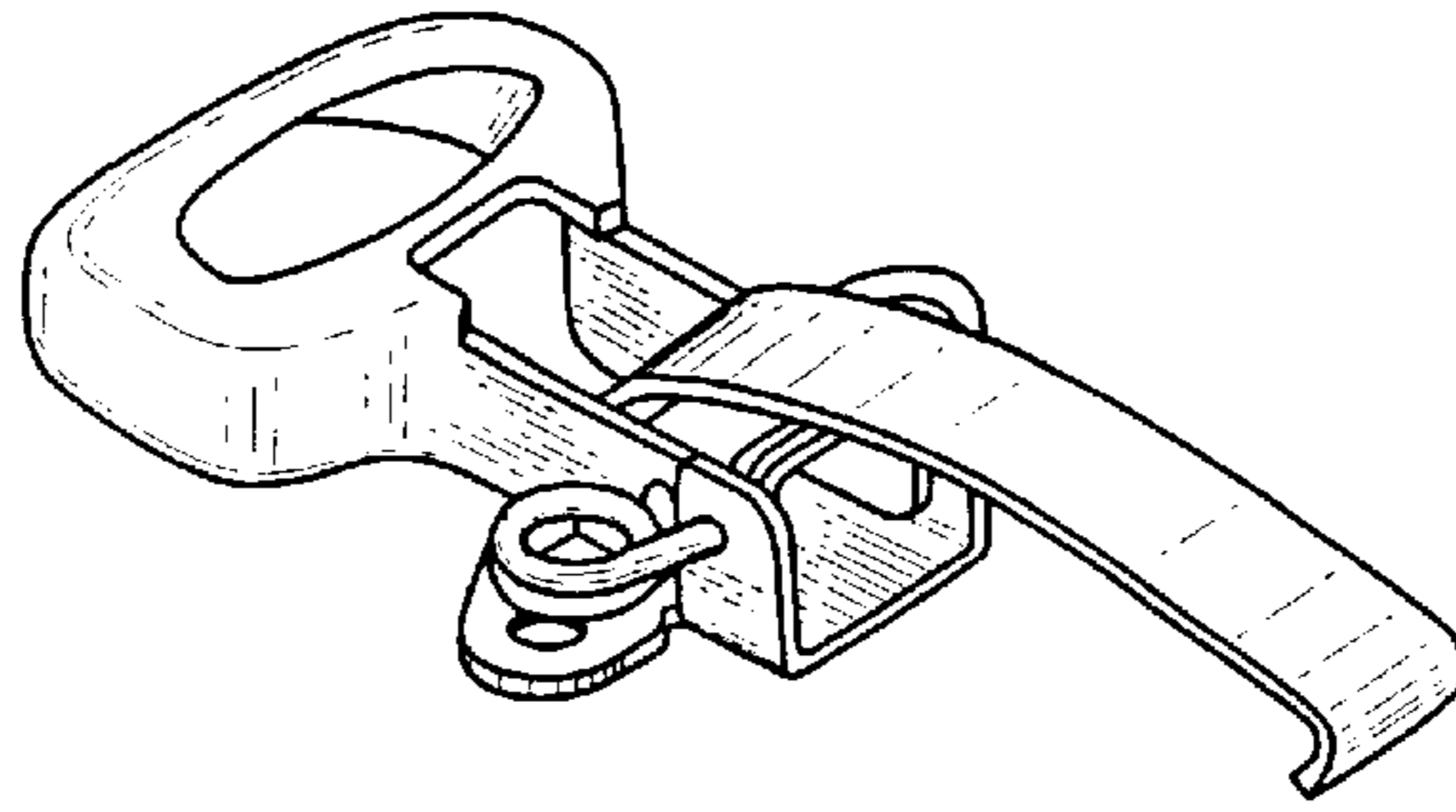

FIG. 1

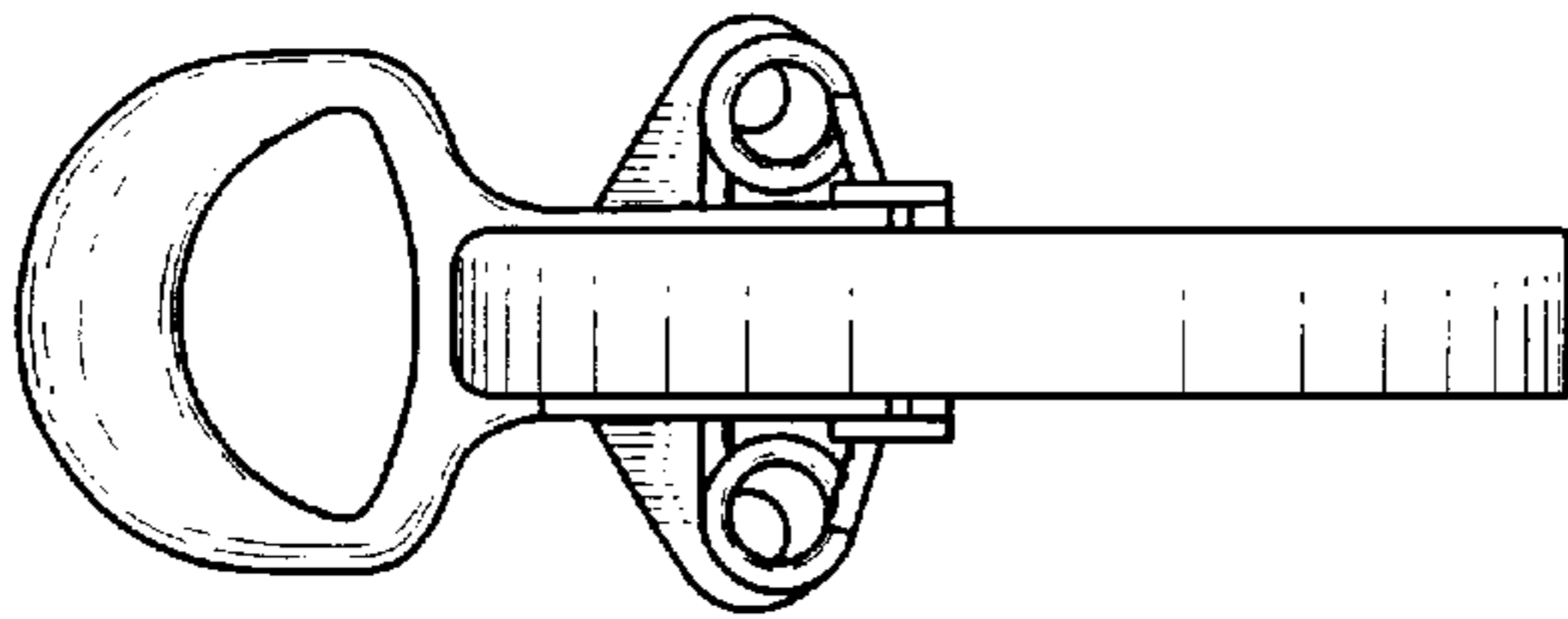

FIG. 2

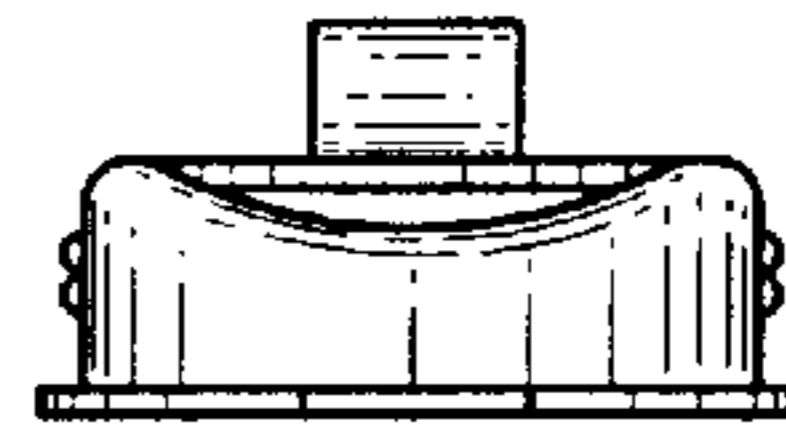

FIG. 3

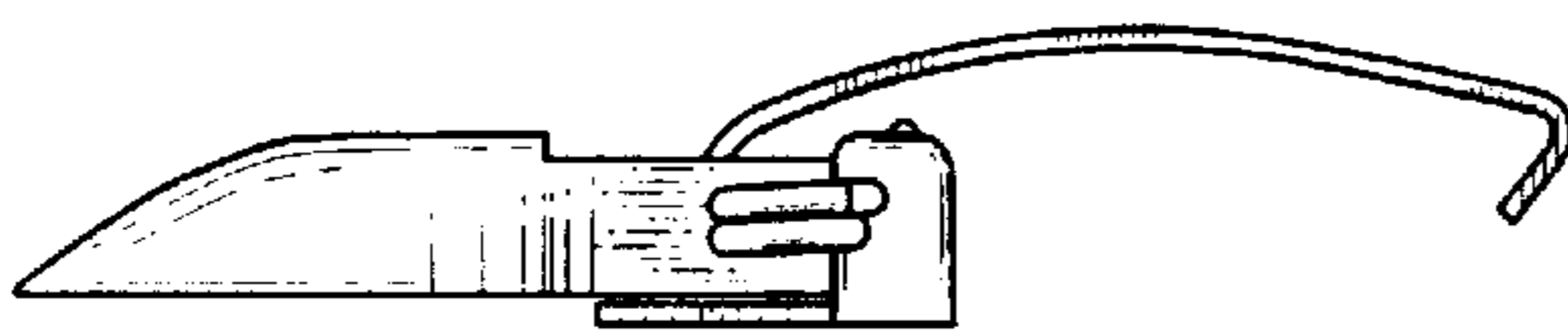

FIG. 4



FIG. 5

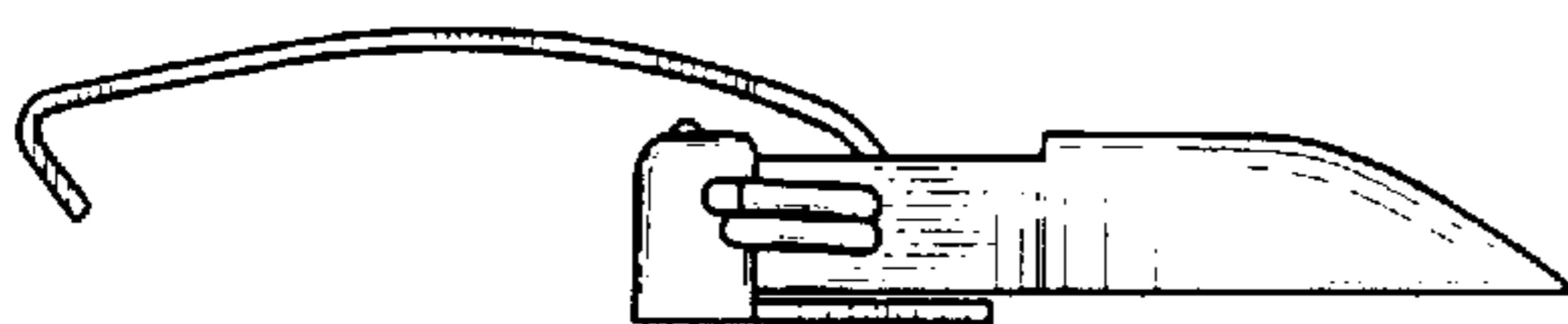

FIG. 6

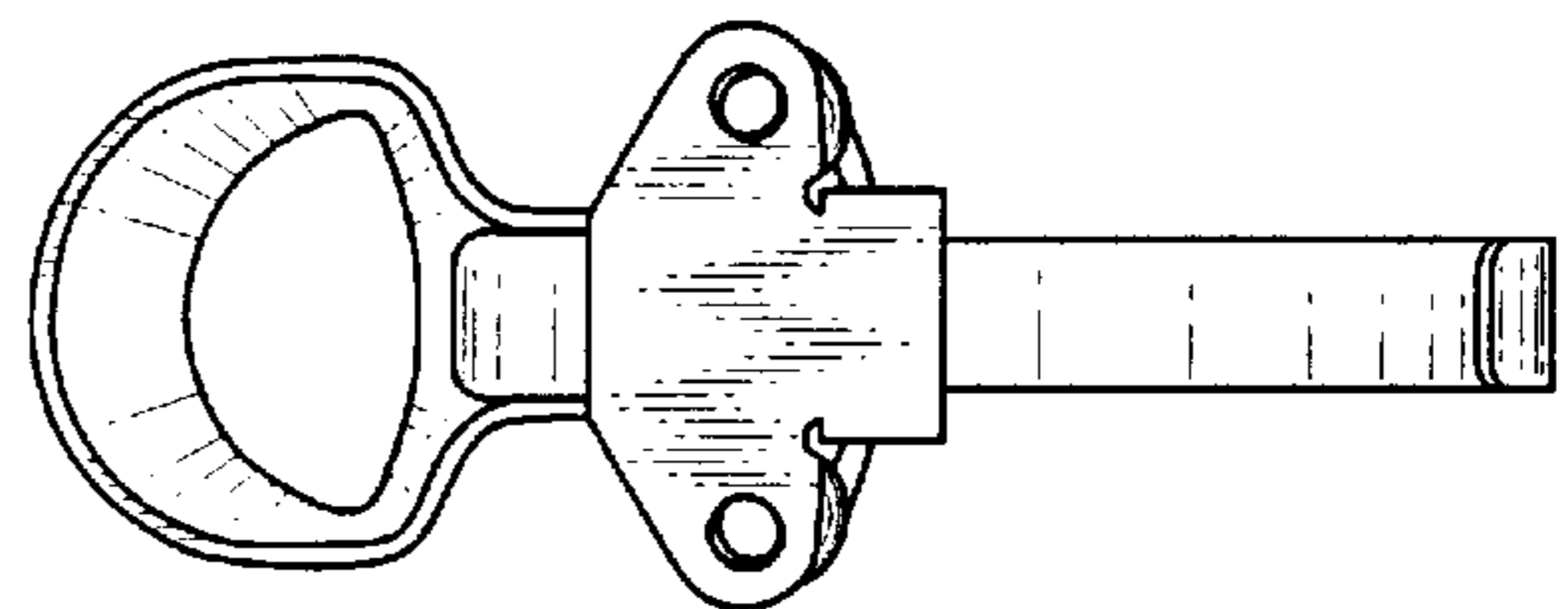

FIG. 7