



US00D435652S

United States Patent [19]

Nazarifar et al.

[11] Patent Number: Des. 435,652

[45] Date of Patent: ** Dec. 26, 2000

[54] SHIELDED FEMALE CONNECTOR

[75] Inventors: Nader Nazarifar, Laguna Niguel; Richard A. Rossback, Irvine; Gary P. Sorensen, Lake Forest, all of Calif.

[73] Assignee: Alcon Laboratories, Inc.

[**] Term: 14 Years

[21] Appl. No.: 29/102,713

[22] Filed: Mar. 30, 1999

[51] LOC (7) Cl. 24-02

[52] U.S. Cl. D24/129; D23/262

[58] Field of Search D24/112, 129, D24/130; D23/259, 262; 285/40, 390; 604/403, 905, 530, 533, 535, 19, 22, 27, 35; 222/566, 567, 568, 571; 606/107

[56] References Cited

U.S. PATENT DOCUMENTS

221,864	11/1879	Robbins .	
D. 302,729	8/1989	Stephens et al.	D24/129
D. 303,291	9/1989	Magrath	D24/129
D. 327,318	6/1992	Dudar et al.	D24/112
D. 363,542	10/1995	Parris et al.	D24/129
D. 395,502	6/1998	Deily et al.	D24/112
591,136	10/1897	Lucas .	
696,059	3/1902	Line .	
714,476	11/1902	Grubbs .	
761,643	6/1904	Backman .	

(List continued on next page.)

FOREIGN PATENT DOCUMENTS

1218237	6/1966	Germany .
67082	11/1943	Norway .
587987	5/1947	United Kingdom .
2198963	6/1988	United Kingdom .

OTHER PUBLICATIONS

Qosina 1999 Components, pp. cover, 36, 54, 55.
Borla 1999 Plastic and Rubber Components for Medical Use, pp. 3, 32-35, 44-45m 47m 49, 50, 60.

Primary Examiner—James Gandy
Assistant Examiner—Reid Hecker
Attorney, Agent, or Firm—Jeffrey S. Schira

[57] CLAIM

The ornamental design for a shielded female connector, as shown and described.

DESCRIPTION

FIG. 1 is an upper, left, rear perspective view of a first embodiment of the shielded female connector of the present invention.

FIG. 2 is an upper, left, front perspective view of a first embodiment of the shielded female connector of the present invention.

FIG. 3 is an upper plan view of a first embodiment of the shielded female connector of the present invention.

FIG. 4 is a front elevational view of a first embodiment of the shielded female connector of the present invention.

FIG. 5 is a left elevational view of a first embodiment of the shielded female connector of the present invention.

FIG. 6 is a rear elevational view of a first embodiment of the shielded female connector of the present invention.

FIG. 7 is an upper, left, rear perspective view of a second embodiment of the shielded female connector of the present invention.

FIG. 8 is an upper, right, front perspective view of a second embodiment of the shielded female connector of the present invention.

FIG. 9 is an upper plan view of a second embodiment of the shielded female connector of the present invention.

FIG. 10 is a front elevational view of a second embodiment of the shielded female connector of the present invention.

FIG. 11 is a left elevational view of a second embodiment of the shielded female connector of the present invention; and,

FIG. 12 is a rear elevational view of a second embodiment of the shielded female connector of the present invention.

The connector of the present invention is used as a fluid connector during microsurgery, particularly ophthalmic surgery, to connect irrigation and aspiration tubings between a surgical handpiece and a control console.

1 Claim, 8 Drawing Sheets

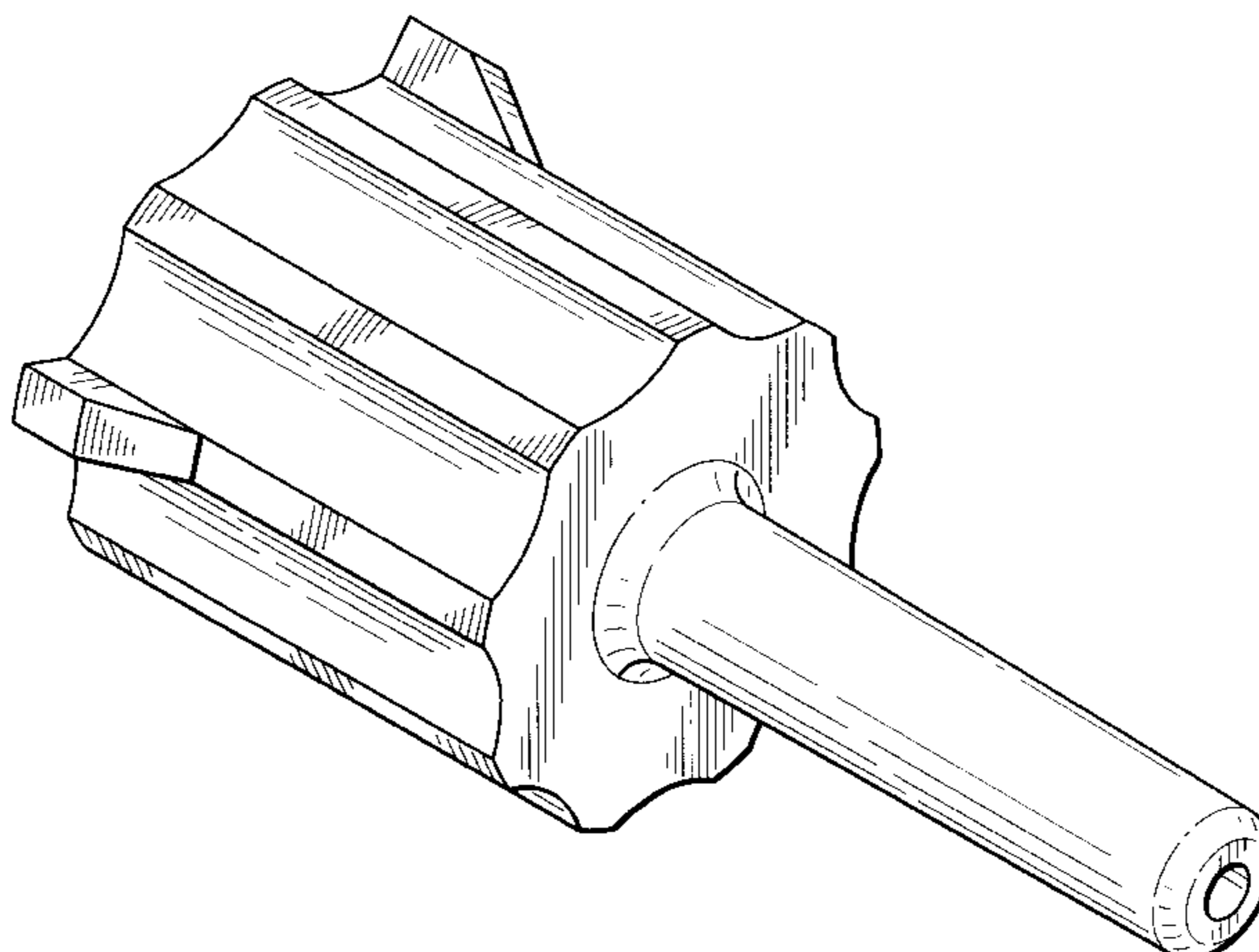

Des. 435,652

Page 2

U.S. PATENT DOCUMENTS						
			4,983,160	1/1991	Steppe et al.	604/22
809,759	1/1906	Toole et al. .	5,176,415	1/1993	Chokisi .	
928,055	7/1909	Johnson et al. .	5,267,984	12/1993	Doherty	604/905
936,566	10/1909	Rosendahl .	5,312,377	5/1994	Dalton	604/905
2,284,216	5/1942	Kunkel .	5,380,301	1/1995	Prichard et al.	604/533
4,508,367	4/1985	Oreopoulous et al. .	5,540,707	7/1996	Ressemann et al.	604/22
4,525,001	6/1985	Lumsden et al. .	5,620,427	4/1997	Werschmidt et al.	604/535
4,790,567	12/1988	Kawano et al. .	5,951,519	9/1999	Utterberg .	
4,808,154	2/1989	Freeman	6,042,586	3/2000	Kawano et al.	606/107

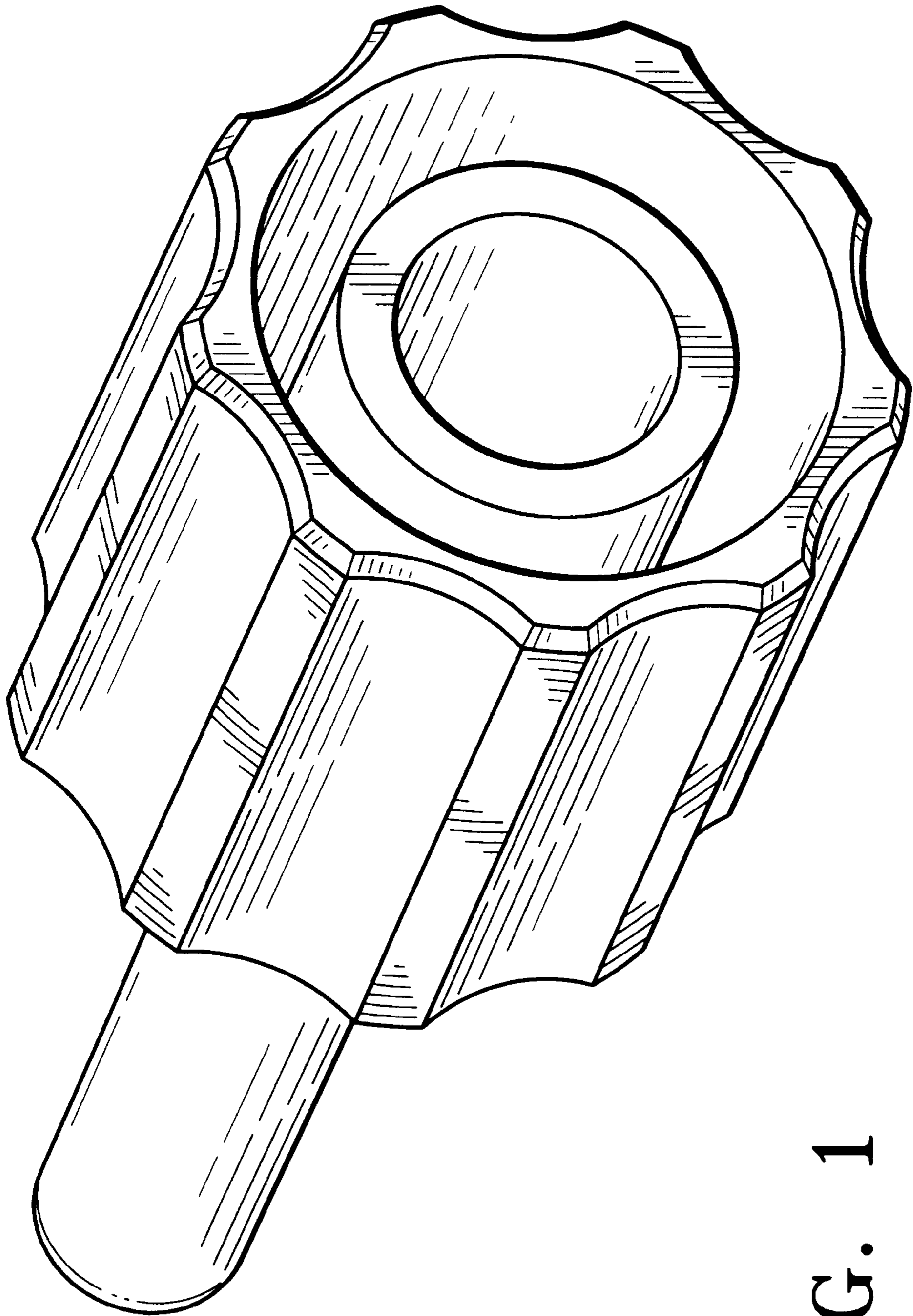

FIG. 1

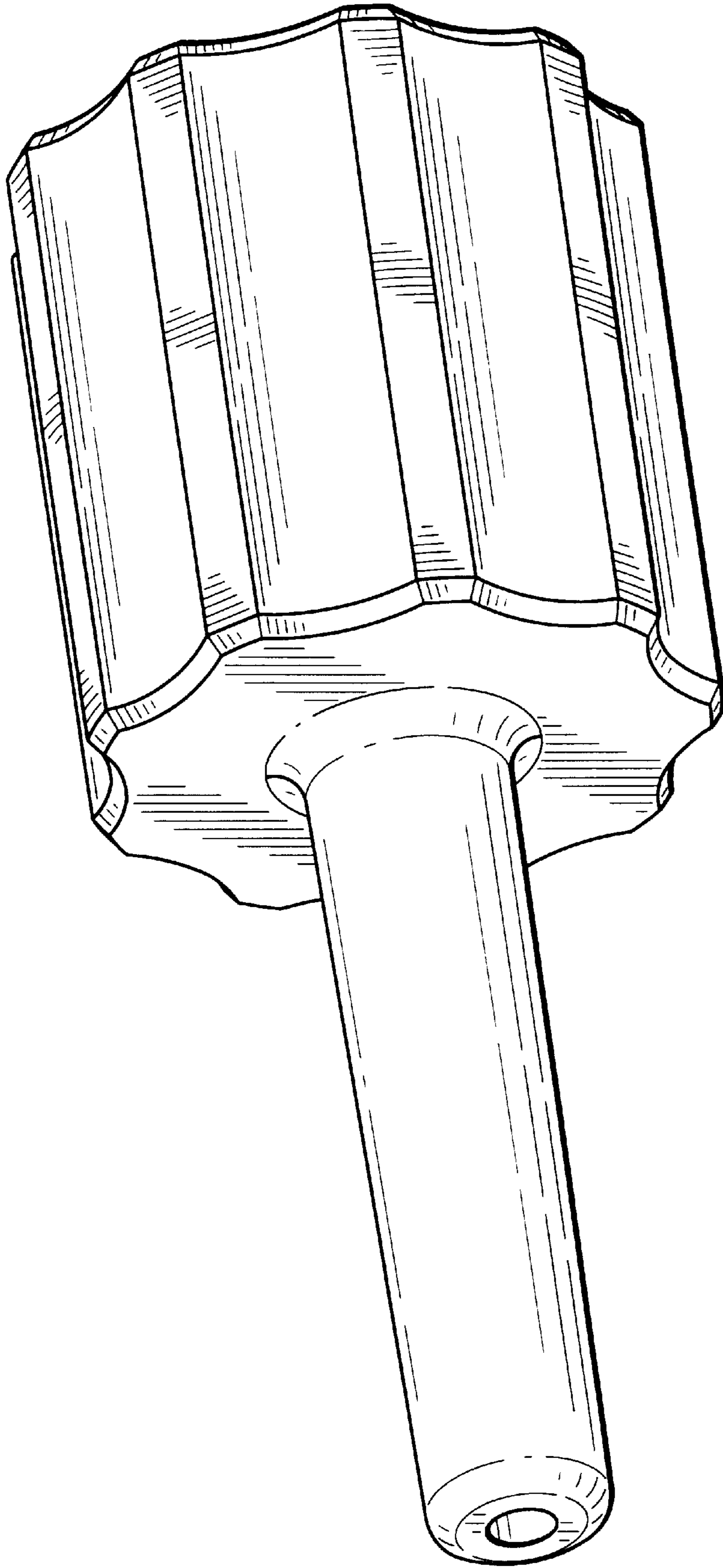

FIG. 2

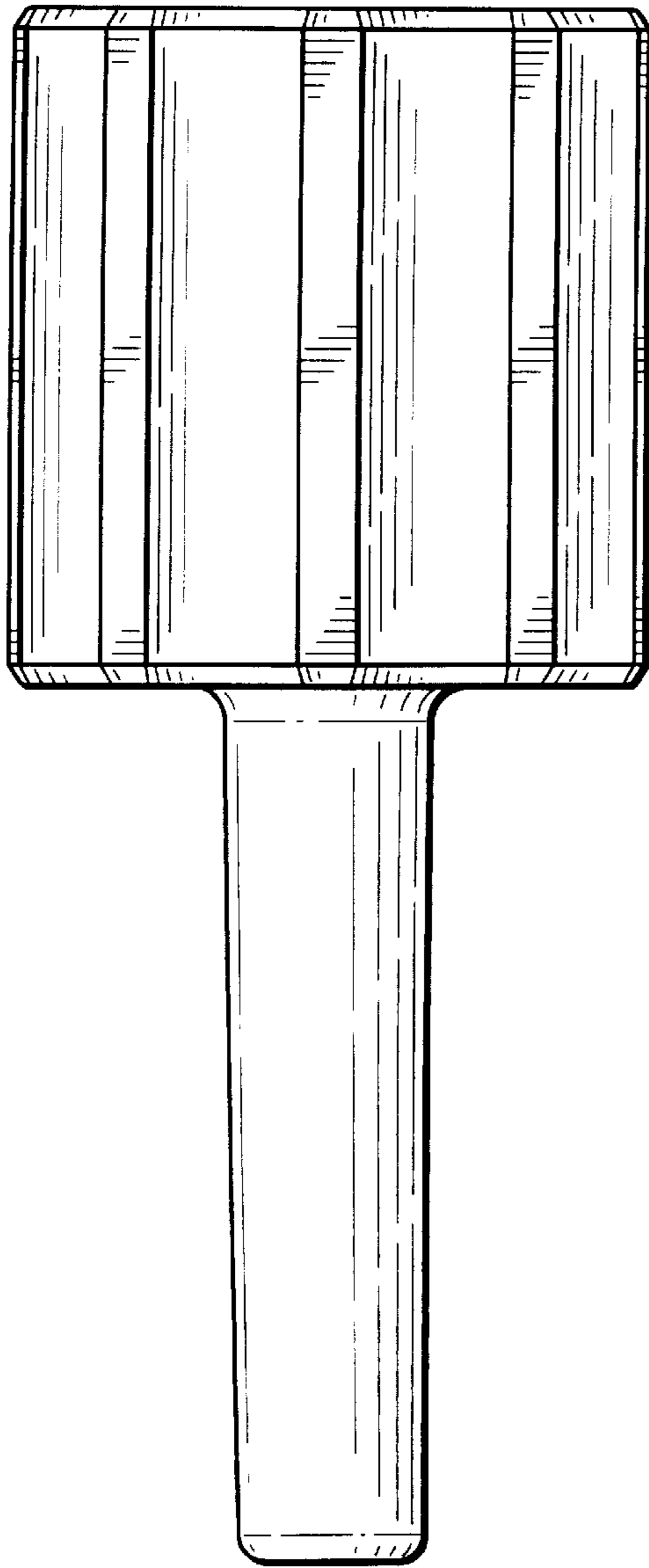

FIG. 3

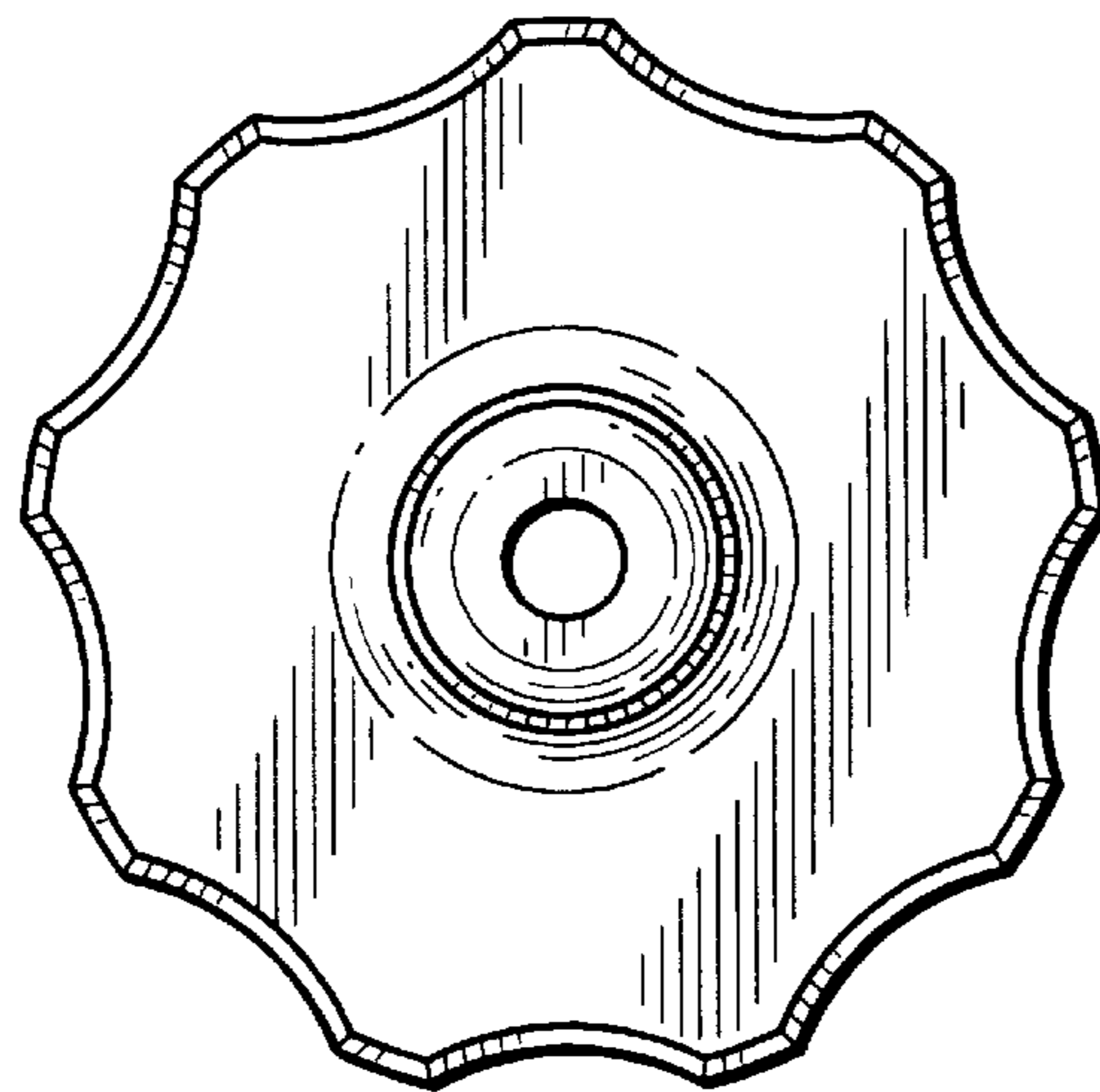

FIG. 4

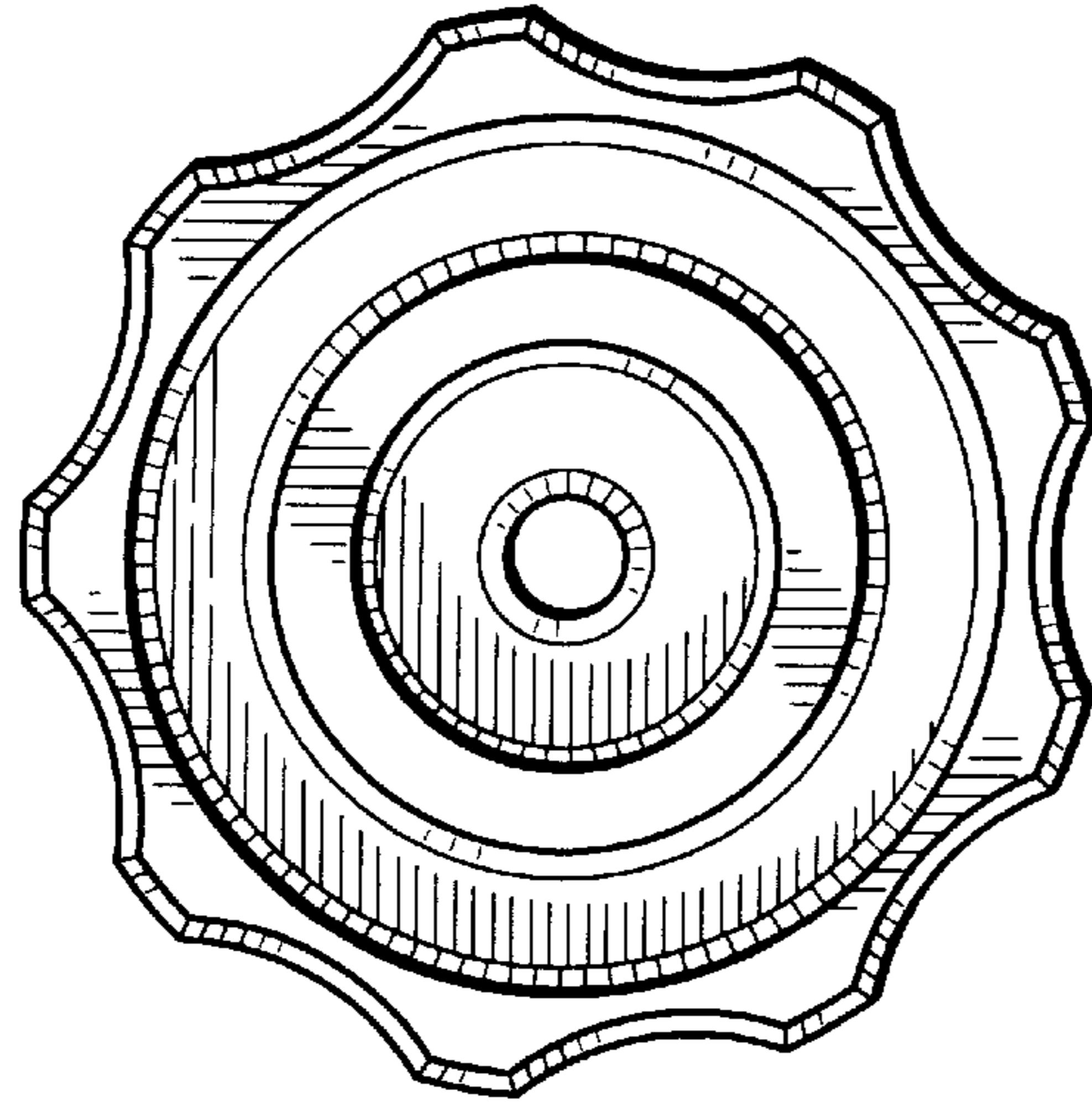

FIG. 6

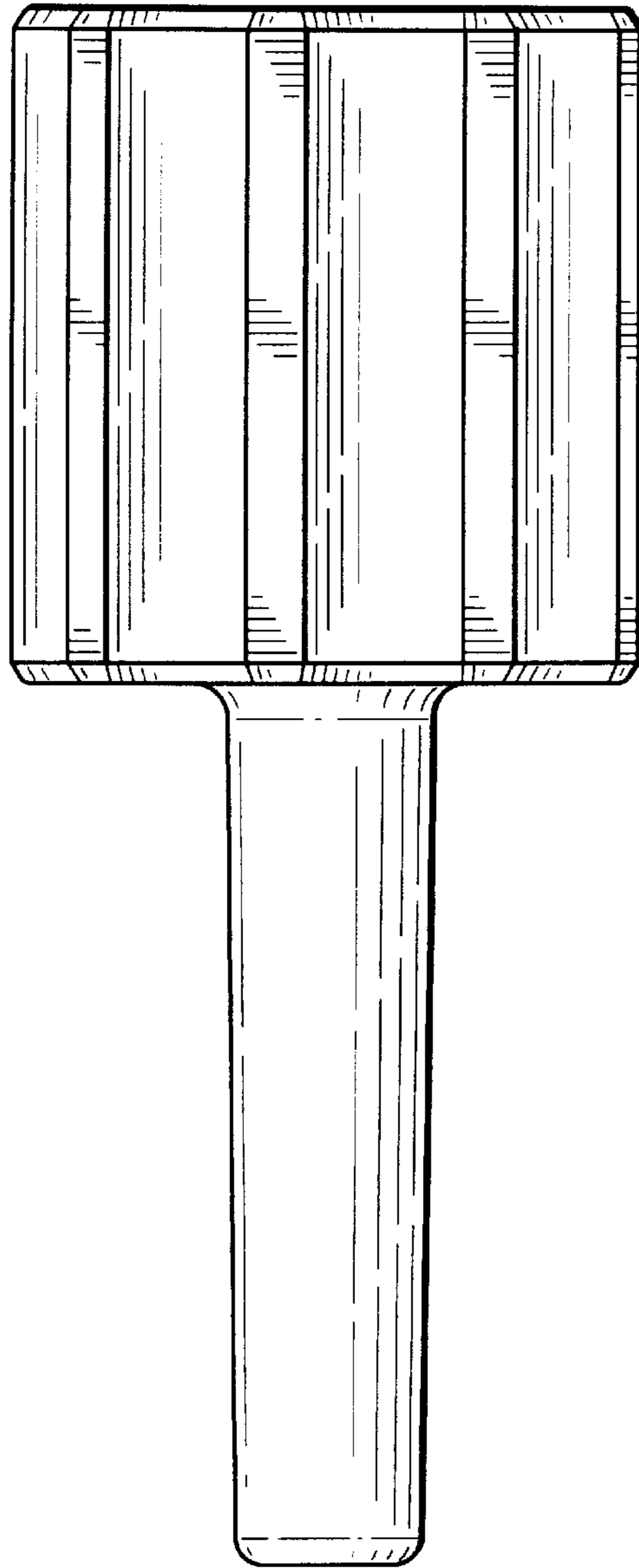

FIG. 5

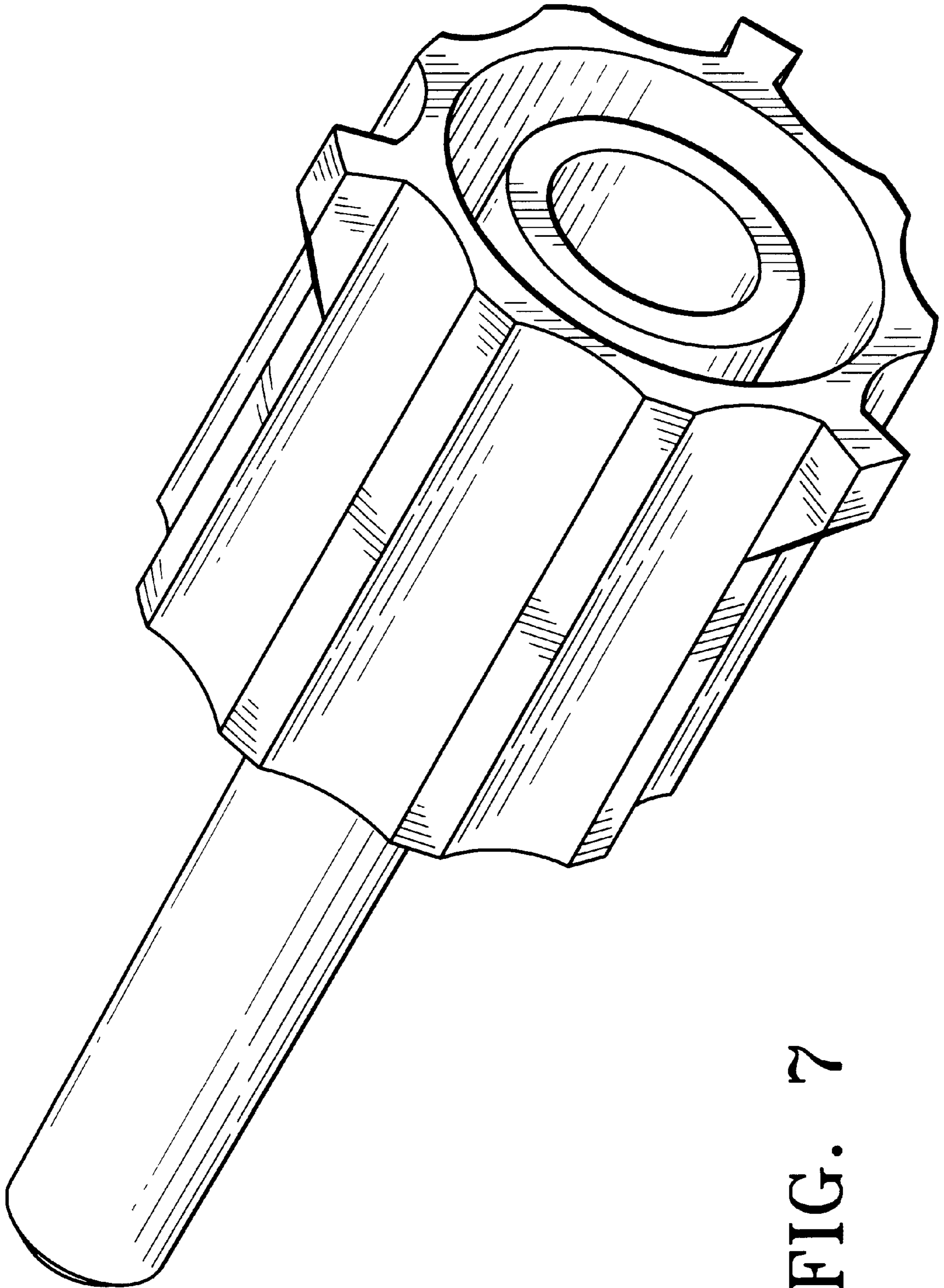
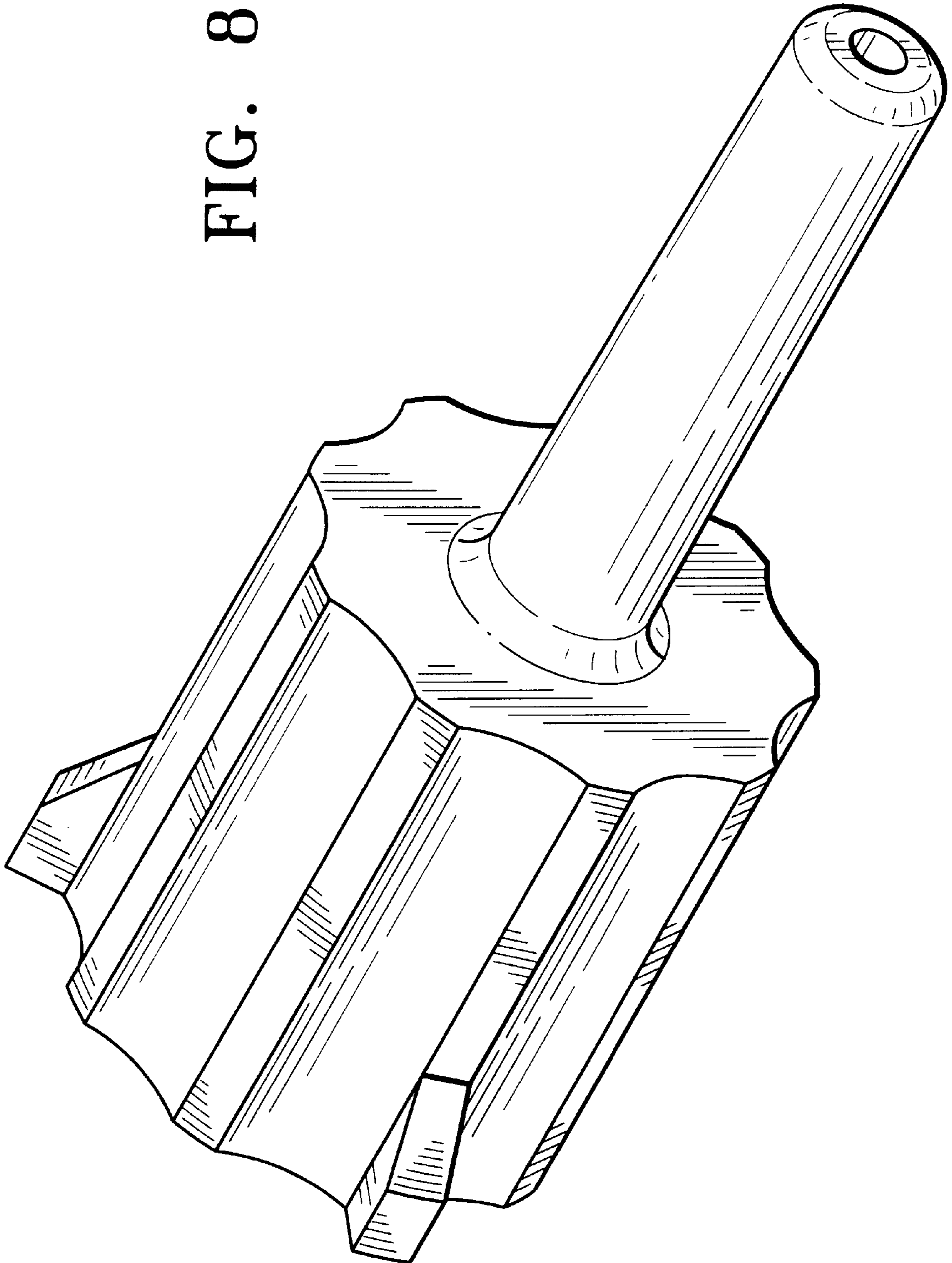

FIG. 7

FIG. 8



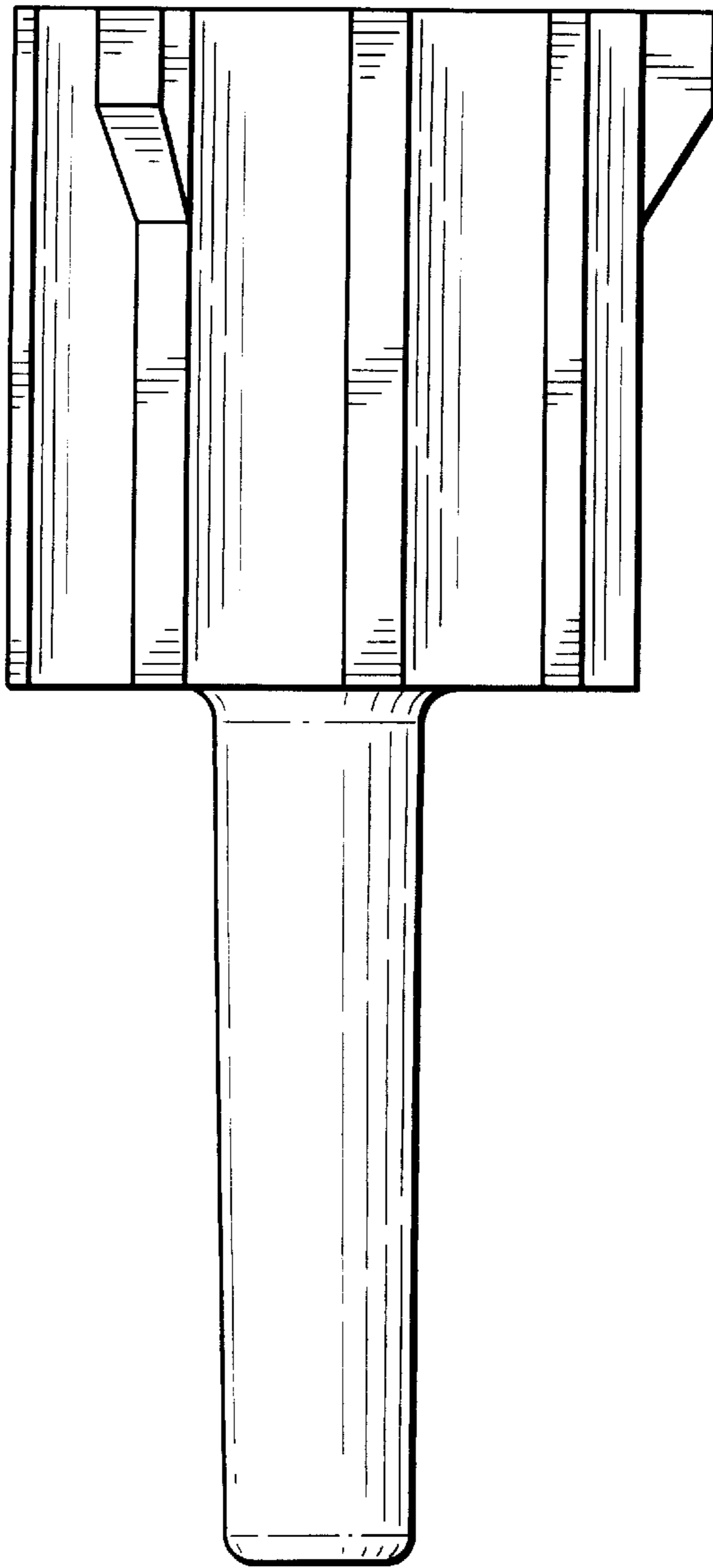

FIG. 9

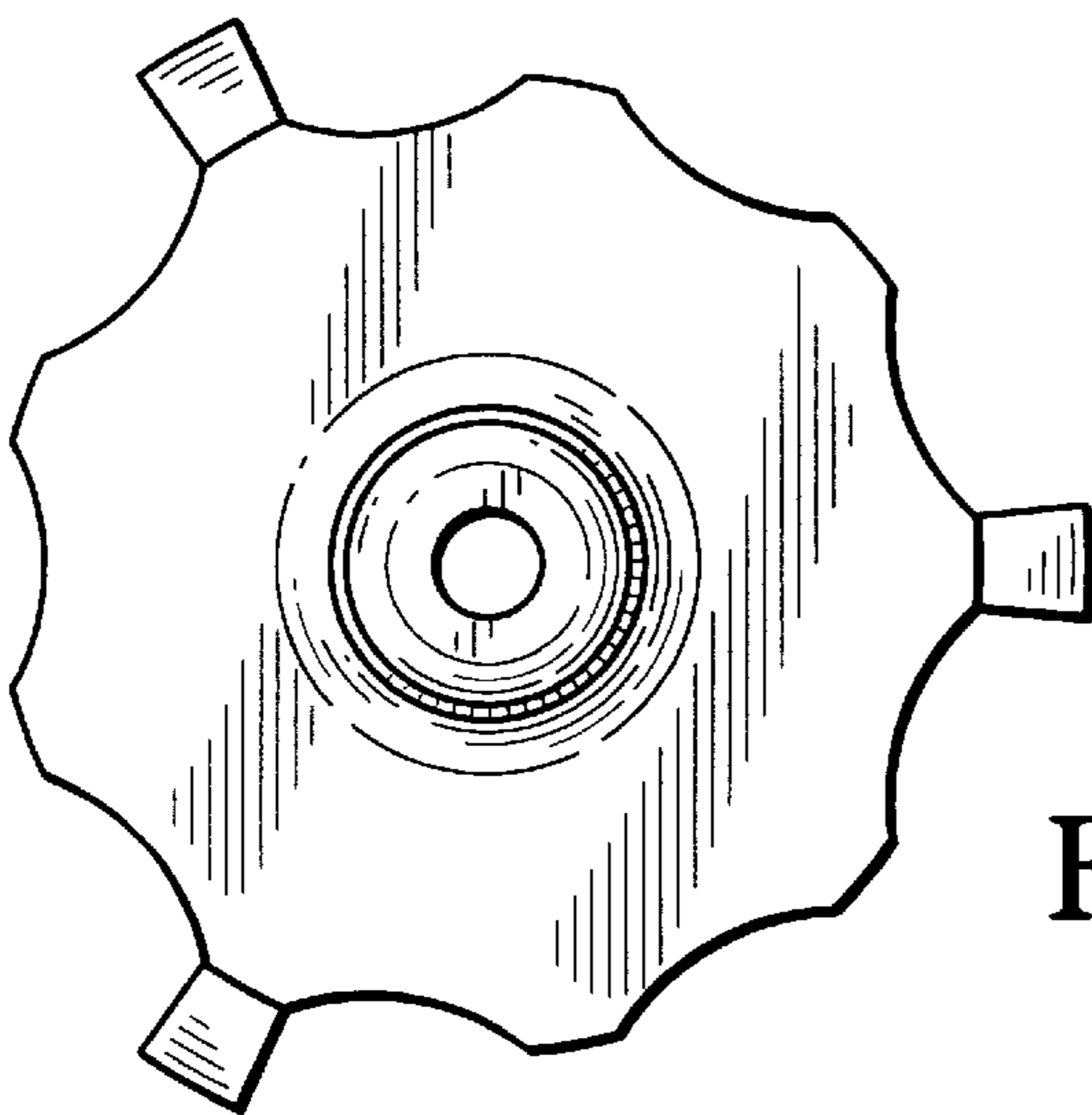

FIG. 10

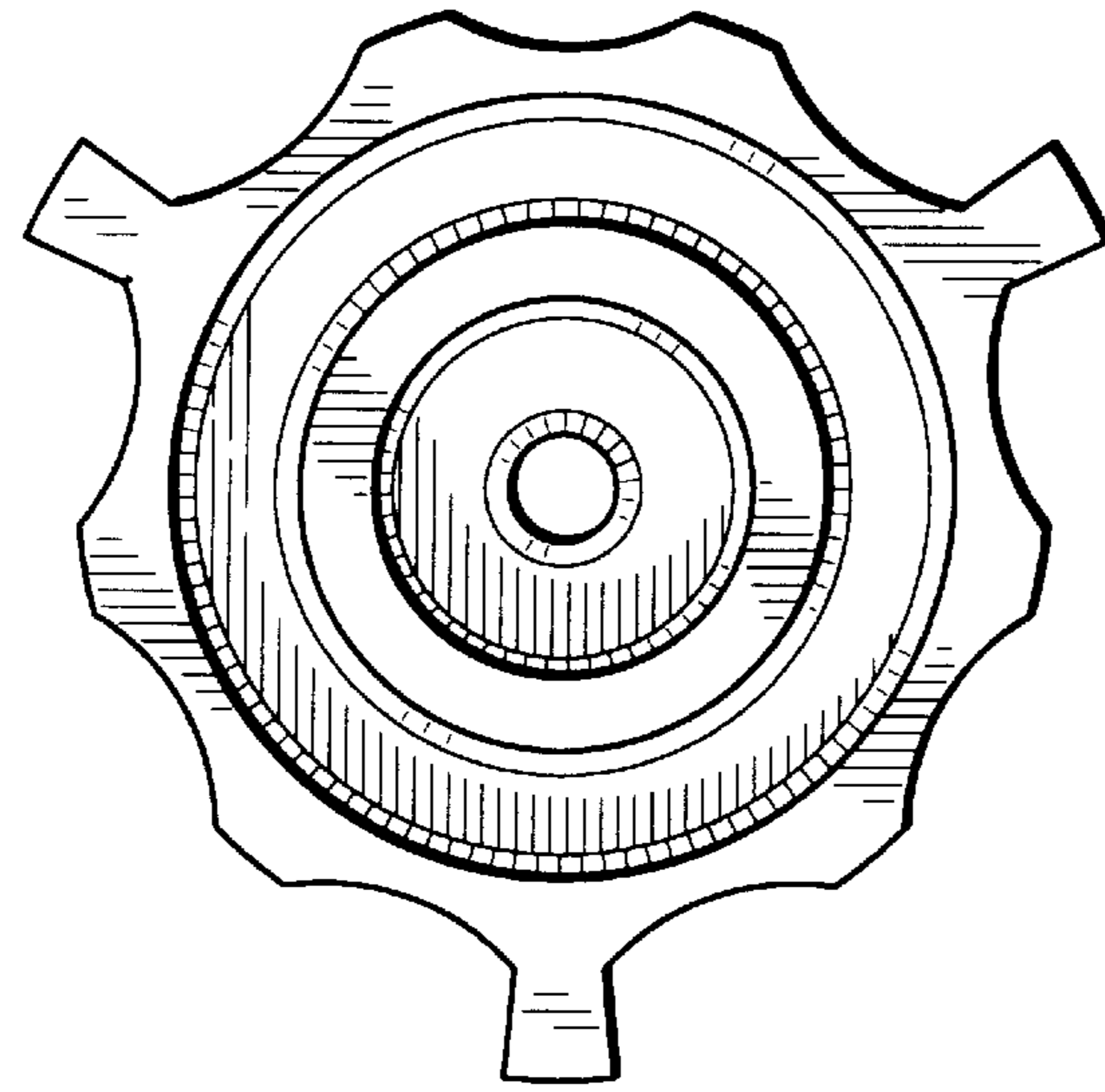

FIG. 12

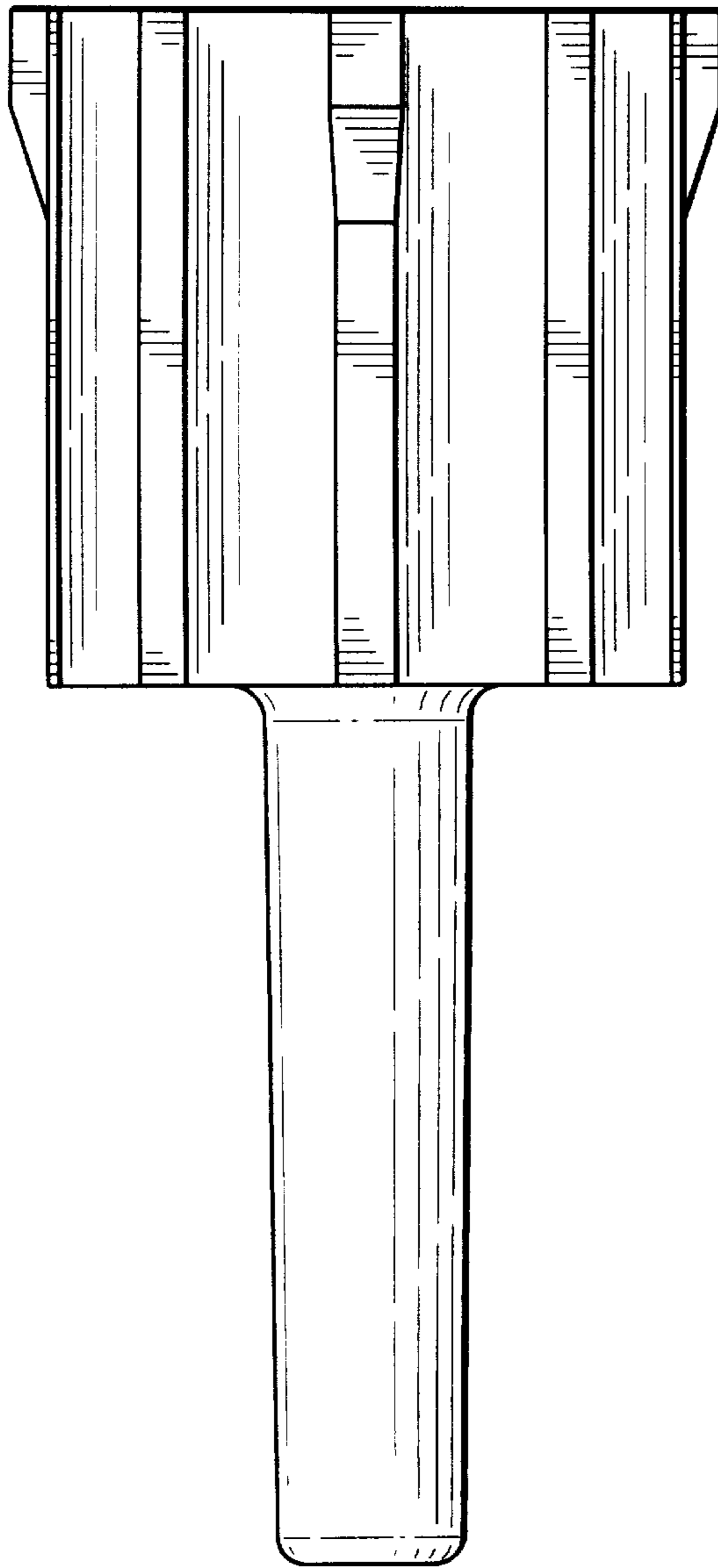

FIG. 11