



US00D435608S

United States Patent [19] Medeiros

[11] Patent Number: **Des. 435,608**

[45] Date of Patent: **** Dec. 26, 2000**

[54] **TOY RIDING VEHICLE**

[76] Inventor: **Matthew J. Medeiros**, 1688 Myles Way, Carson City, Nev. 89701

[**] Term: **14 Years**

[21] Appl. No.: **29/117,166**

[22] Filed: **Jan. 18, 2000**

[51] **LOC (7) Cl.** **21-01**

[52] **U.S. Cl.** **D21/421; D21/423; D21/424**

[58] **Field of Search** D21/419-435, D21/533, 534, 548-551, 561-563; D12/87, 88, 128, 130; 446/160, 447, 428, 456, 465, 470; 280/1.13, 87.01, 87.021, 87.041, 87.042, 87.051

[56] **References Cited**

U.S. PATENT DOCUMENTS

D. 210,087	2/1968	Higgins et al.	D21/423
D. 291,211	8/1987	Man	D21/423
2,045,983	6/1936	Ferrigno	D21/423
3,438,642	4/1969	Kite et al.	D21/421
4,279,043	7/1981	Saunders	280/87.041

5,538,268	7/1996	Miller	280/87.041
5,785,331	7/1998	Rappaport	280/87.041
5,839,740	11/1998	Seeger	280/87.01

Primary Examiner—Raphael Barkai
Attorney, Agent, or Firm—Brian C. Kelly

[57] **CLAIM**

The ornamental design for a toy riding vehicle, as shown and described.

DESCRIPTION

The invention is a design for a non motorized vehicle which is driven by the up and down motion of the pedals. This vehicle allows the rider to be upright rather than seated and also provides a stable wide stance platform.

FIG. 1 is a front perspective view of a toy riding vehicle showing my new design;

FIG. 2 is a top view thereof;

FIG. 3 is right side view thereof;

FIG. 4 is a left side view thereof;

FIG. 5 is a front view thereof;

FIG. 6 is a rear view thereof; and,

FIG. 7 is a bottom view thereof.

1 Claim, 3 Drawing Sheets

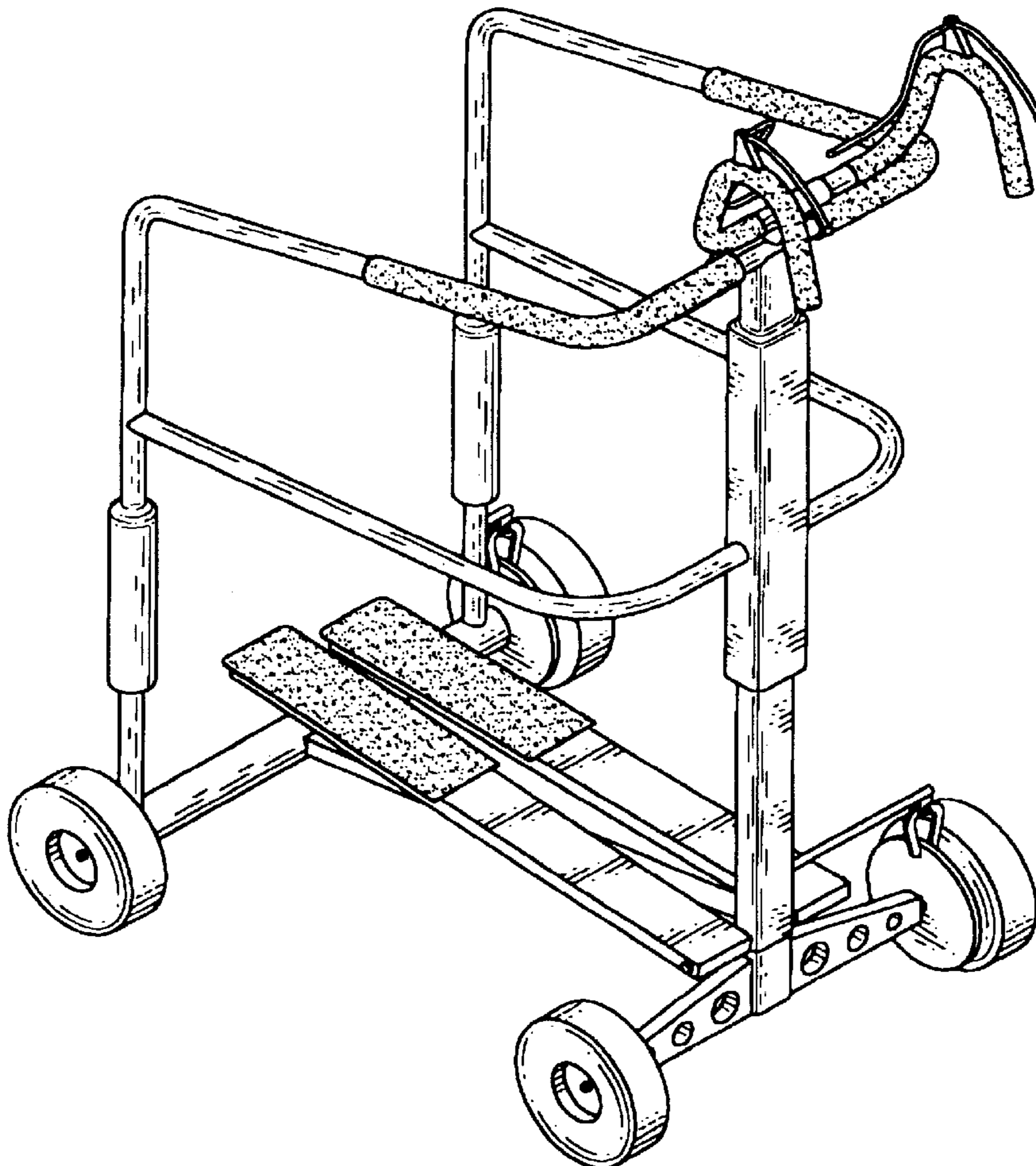

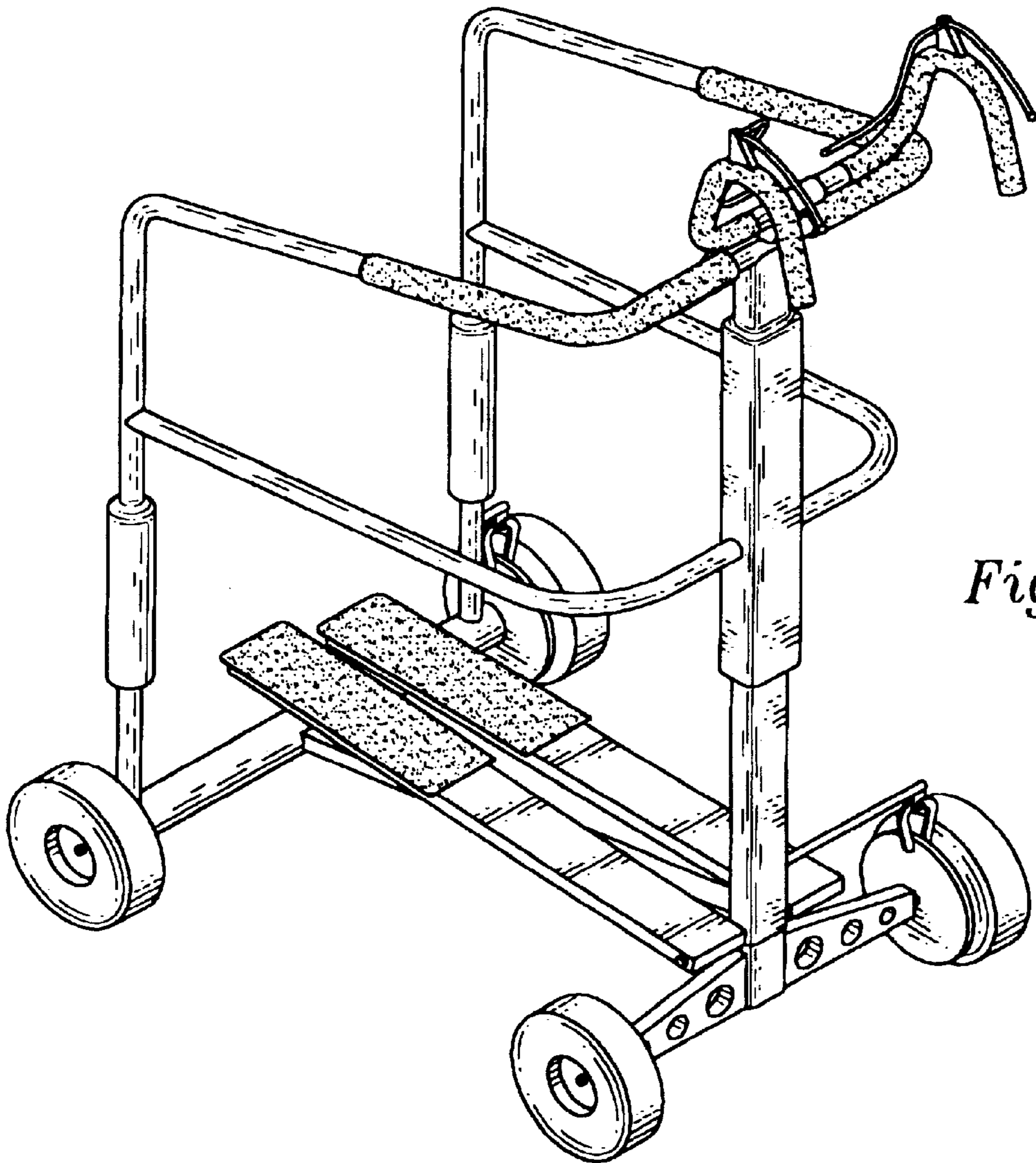

Fig. 1

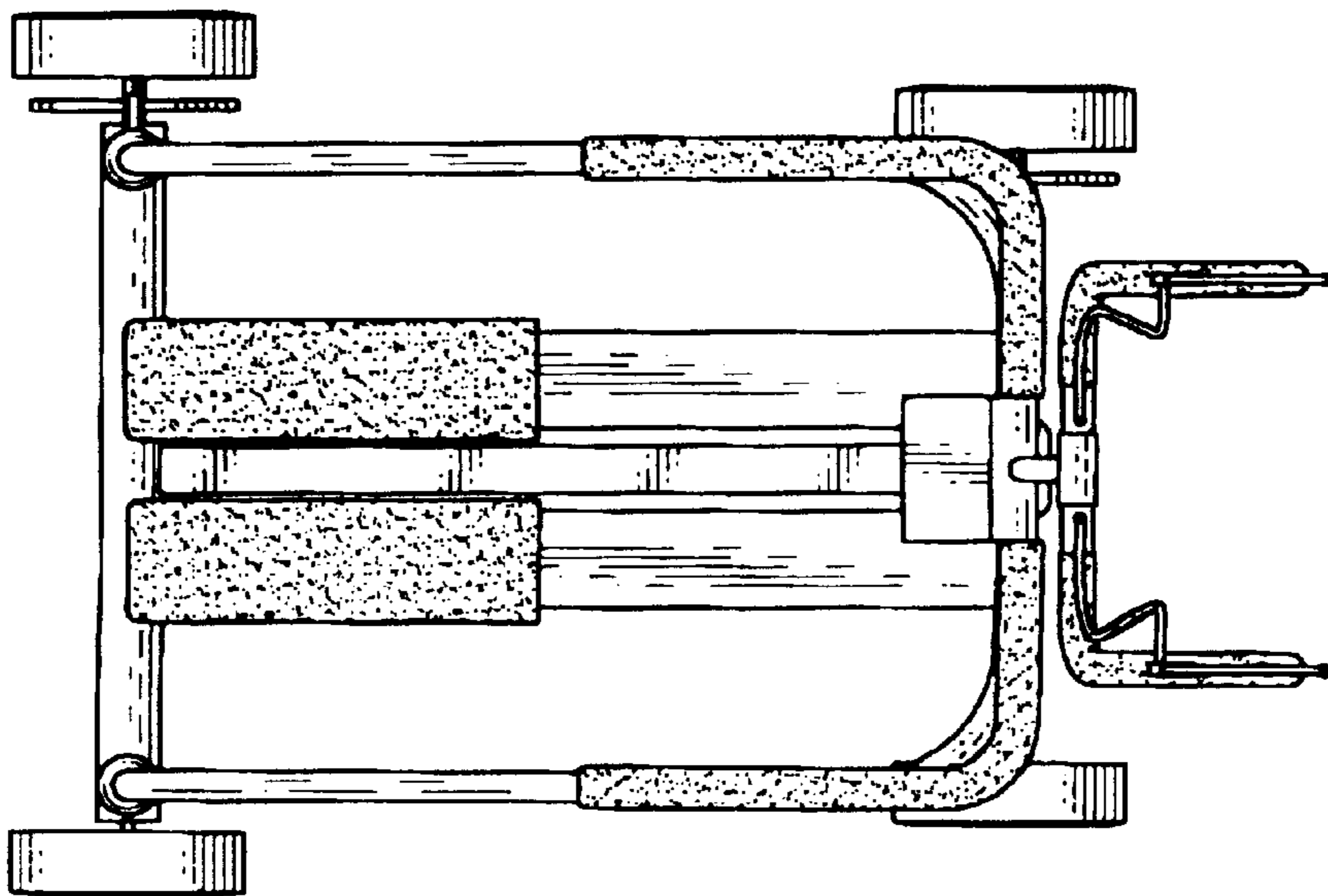

Fig. 2

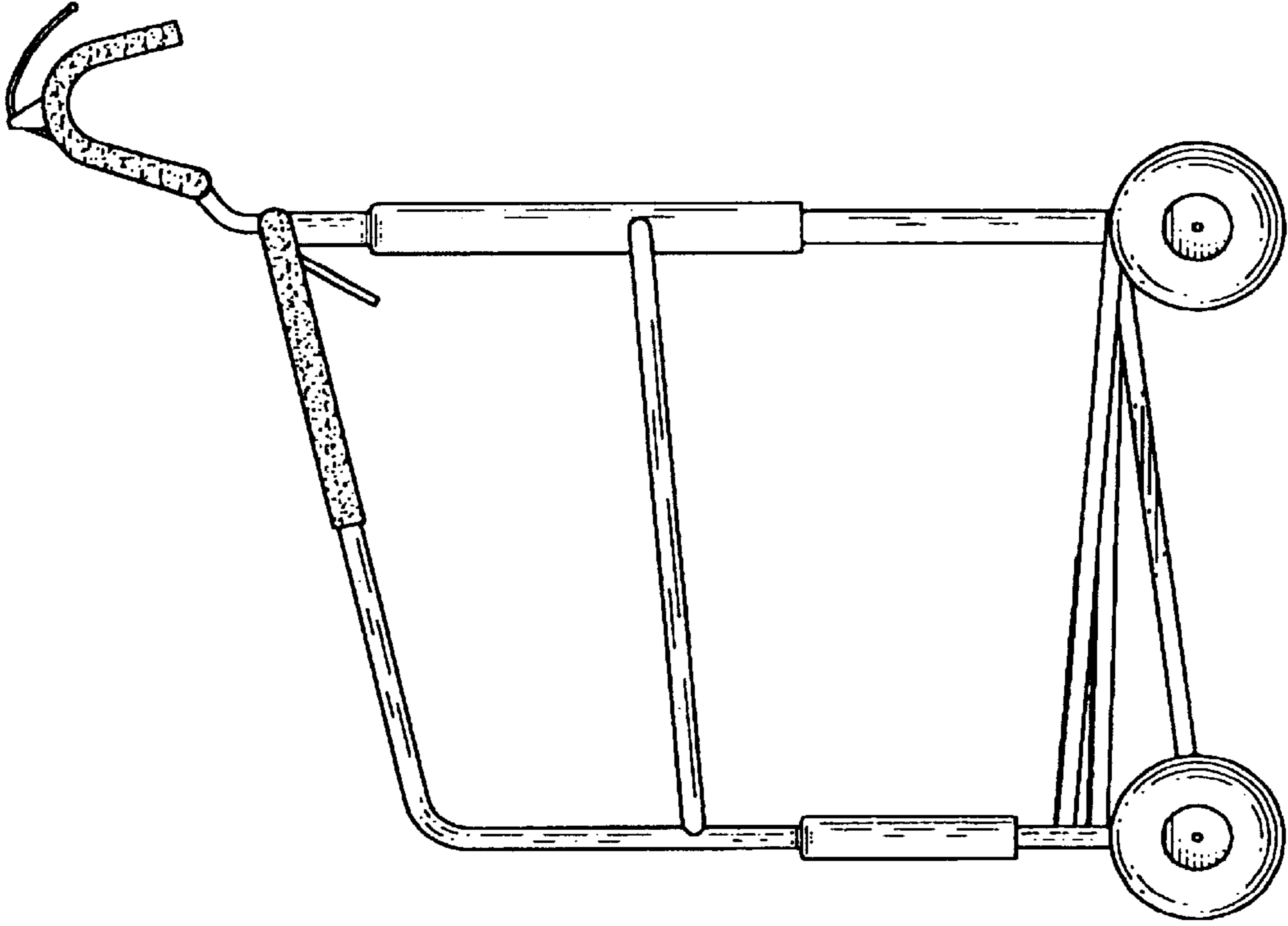

Fig. 4

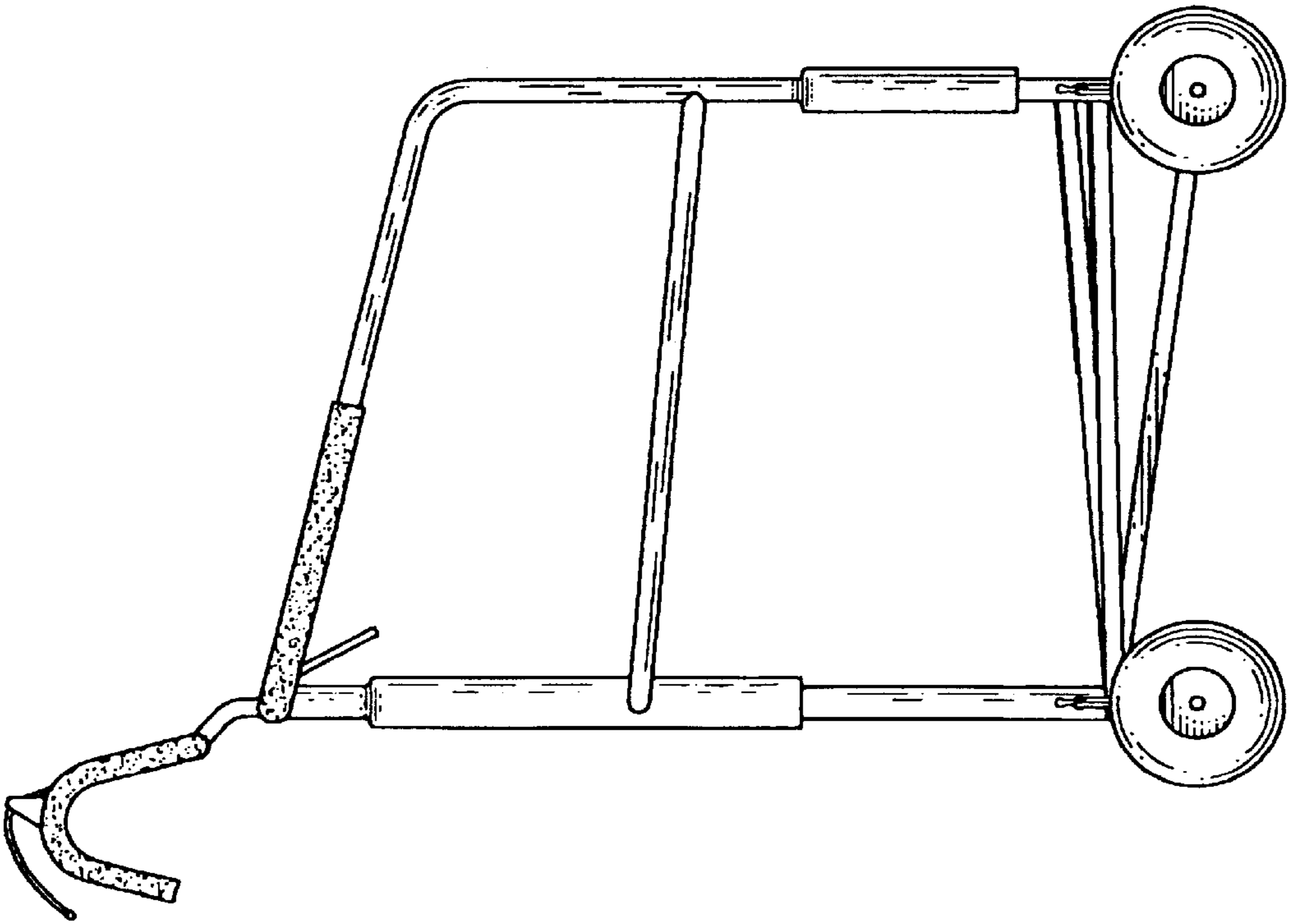

Fig. 3

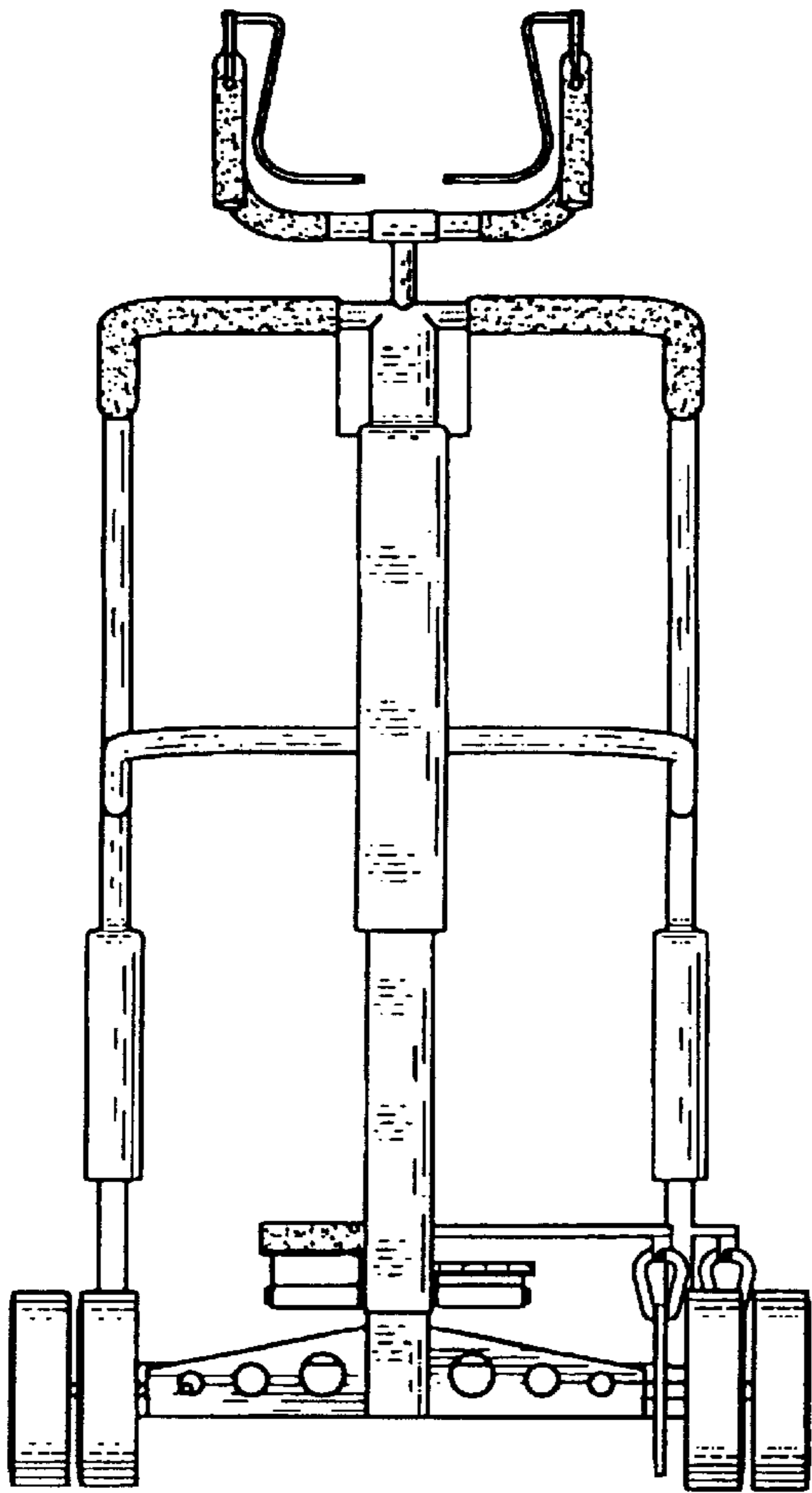

Fig. 5

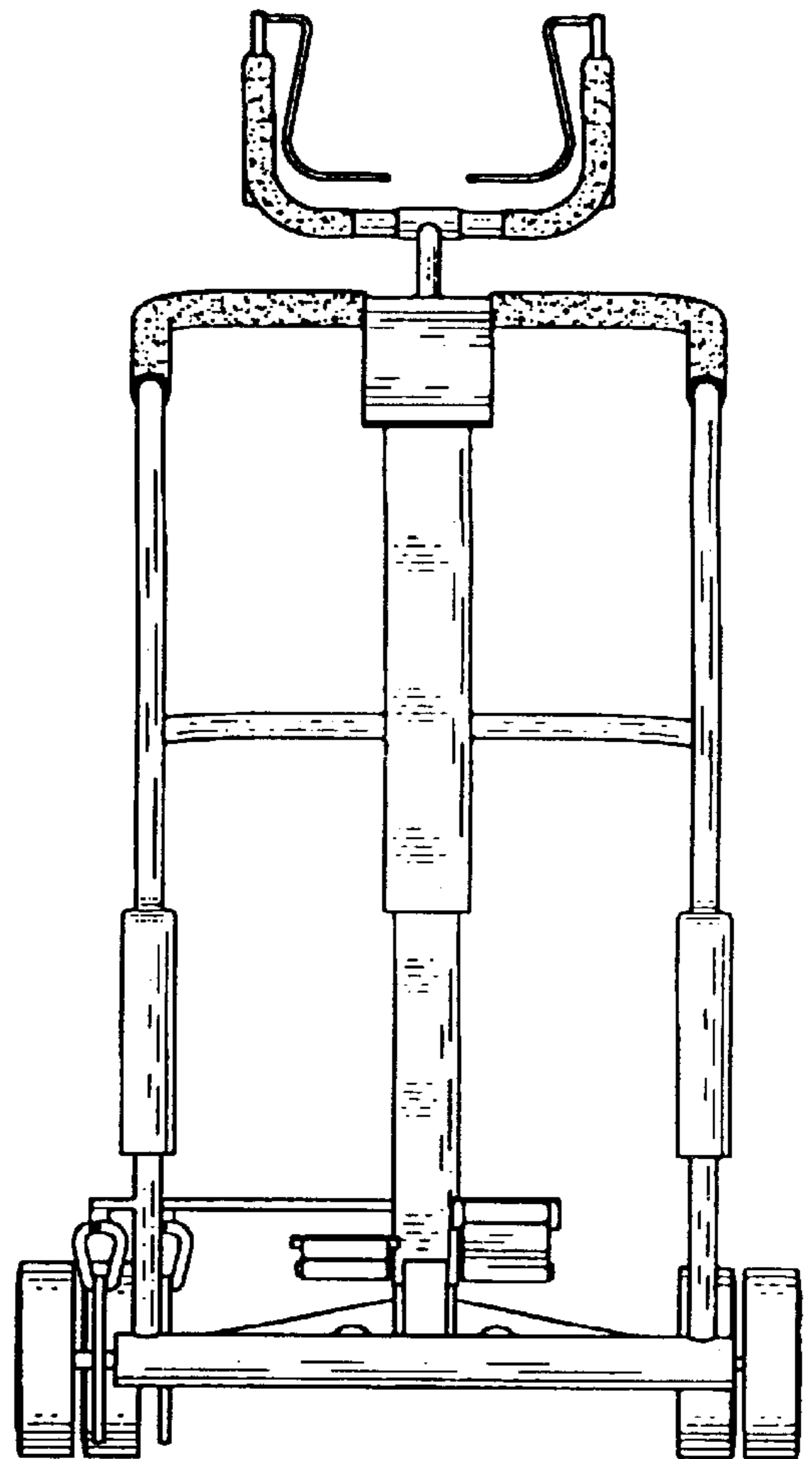

Fig. 6

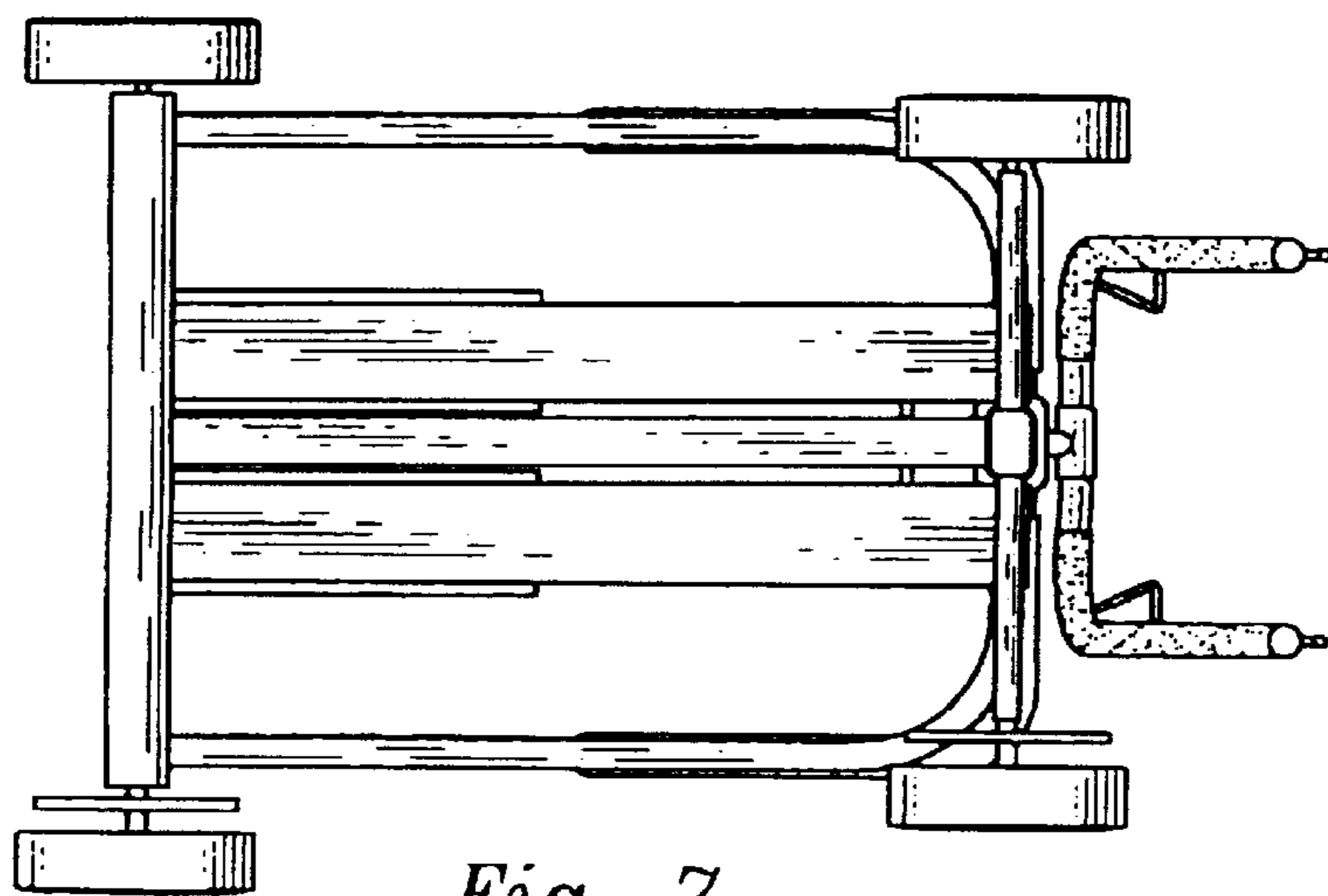

Fig. 7