



US00D435493S

United States Patent [19]
Jewell et al.

[11] **Patent Number: Des. 435,493**
[45] **Date of Patent: ** Dec. 26, 2000**

[54] **PATIENT TRANSPORT DEVICE**

[75] Inventors: **William Moody Jewell**, 18 Bayview Dr., Portland, Me. 04103; **James A. Moschenross**, Burbank, Calif.

[73] Assignee: **William Moody Jewell**, Portland, Me.

[**] Term: **14 Years**

[21] Appl. No.: **29/113,108**

[22] Filed: **Nov. 1, 1999**

[51] **LOC (7) Cl.** **12-12**

[52] **U.S. Cl.** **D12/128; D12/133**

[58] **Field of Search** **D12/128-133;**
5/627

[56] **References Cited**

U.S. PATENT DOCUMENTS

2,362,721	11/1944	Reynolds	5/627
2,678,452	5/1954	Beem et al.	.	
4,064,574	12/1977	Schnitzler	5/627
4,644,594	2/1987	Johnson	D12/128 X
4,751,754	6/1988	Bailey et al.	D12/128 X

Primary Examiner—Kay H. Chin
Attorney, Agent, or Firm—Diller, Ramik & Wight, PC

[57] **CLAIM**

The ornamental design for a patient transport device, as shown and described.

DESCRIPTION

FIG. 1 is a top perspective view of a patient transport device showing our new design in the prone position thereof; FIG. 2 is a side perspective view thereof; FIG. 3 is an end perspective view thereof; FIG. 4 is end perspective view thereof; FIG. 5 is an end perspective view thereof in one of several adjustable seat positions; FIG. 6 is a top perspective view of the seat position; FIG. 7 is a side elevational view of the seat position and the opposite unillustrated side being substantially a mirror image thereof; FIG. 8 is a side elevational view of another adjusted seat position; FIG. 9 is a top plan view of the patient support in the prone position; FIG. 10 is a bottom plan view of the prone position; FIG. 11 is a side elevational view of the prone position and the opposite unillustrated side being substantially a mirror image; and, FIG. 12 is an end elevational view and the opposite unillustrated side being a mirror image.

1 Claim, 4 Drawing Sheets

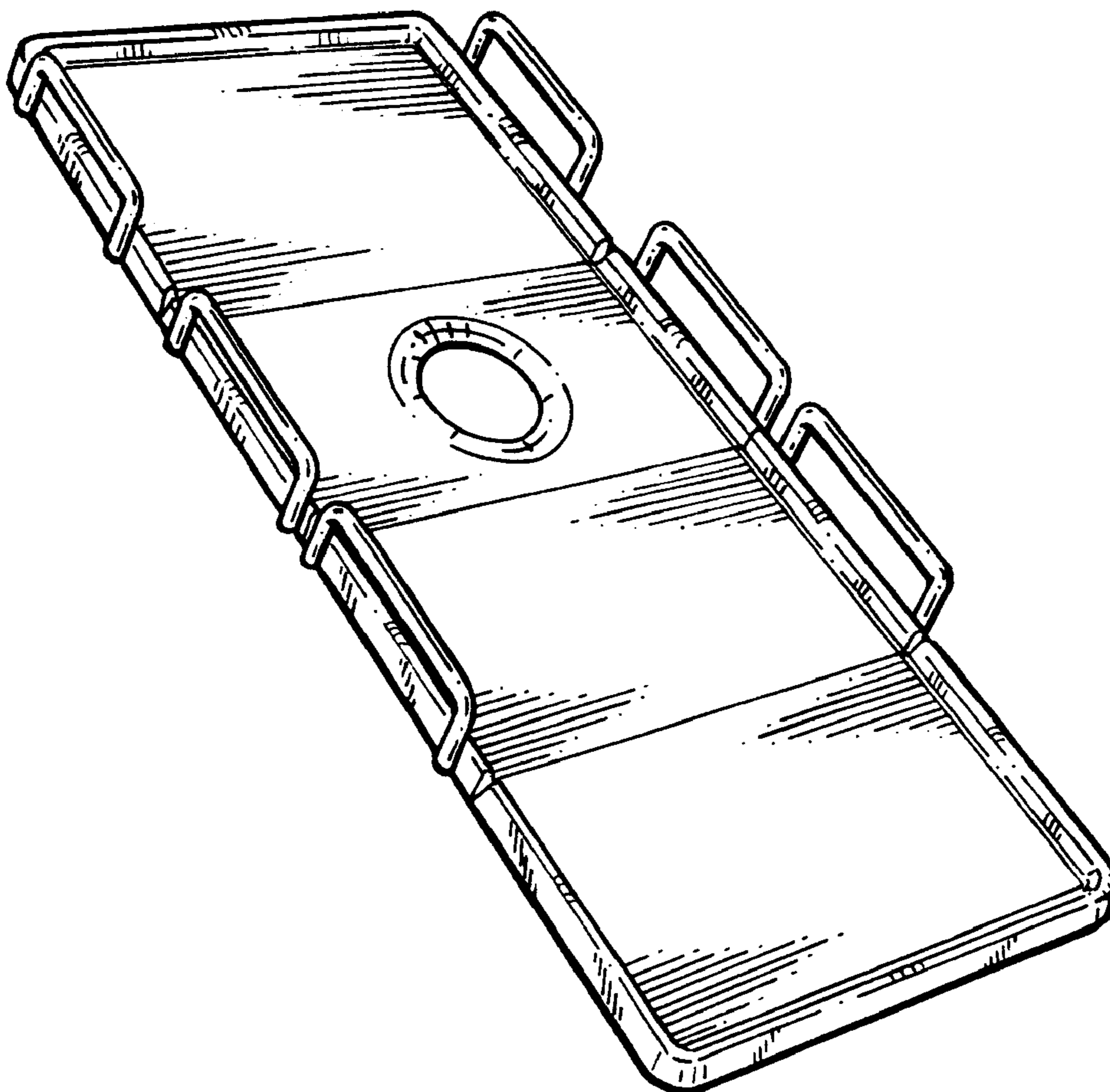

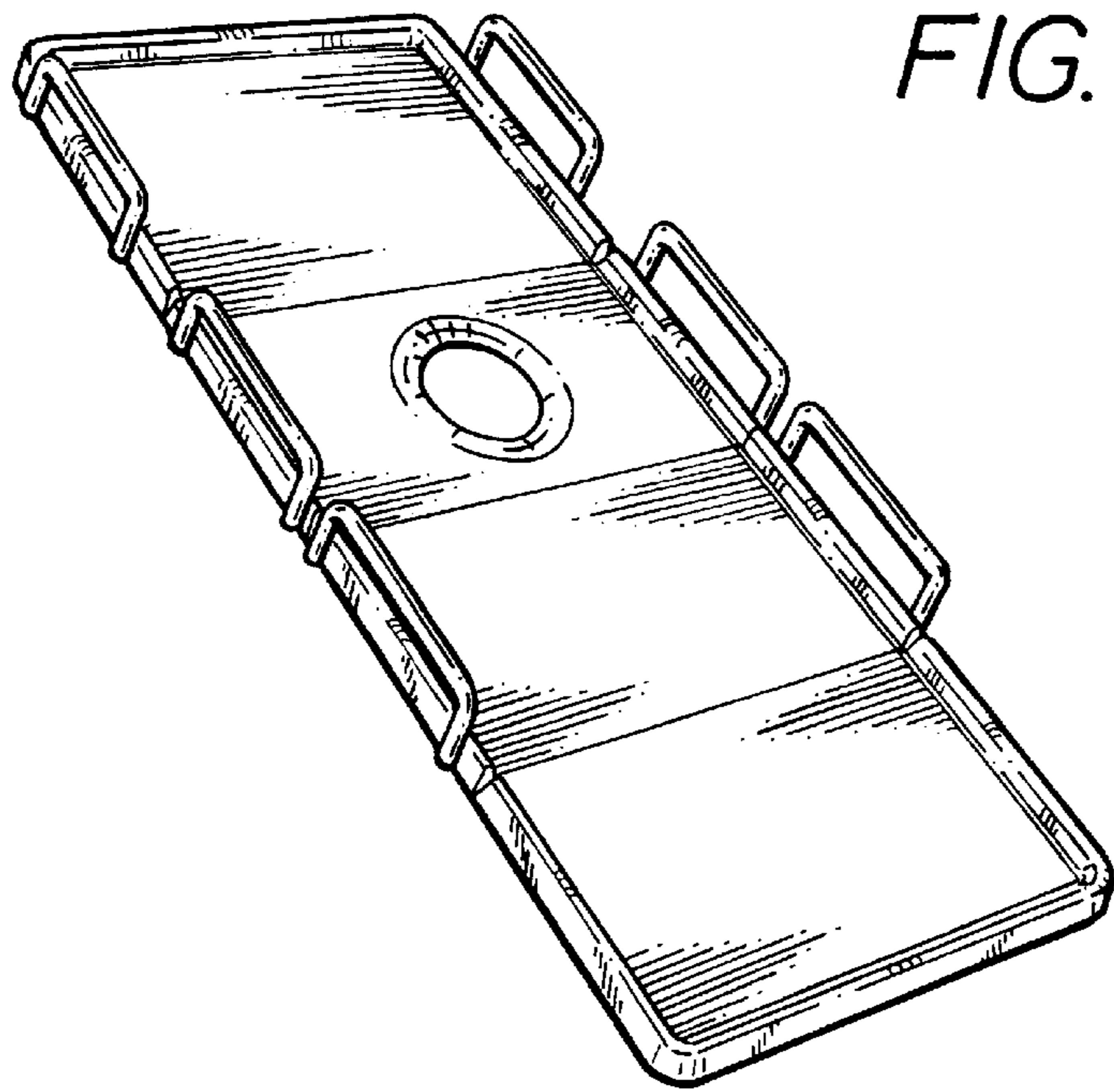

FIG. 2

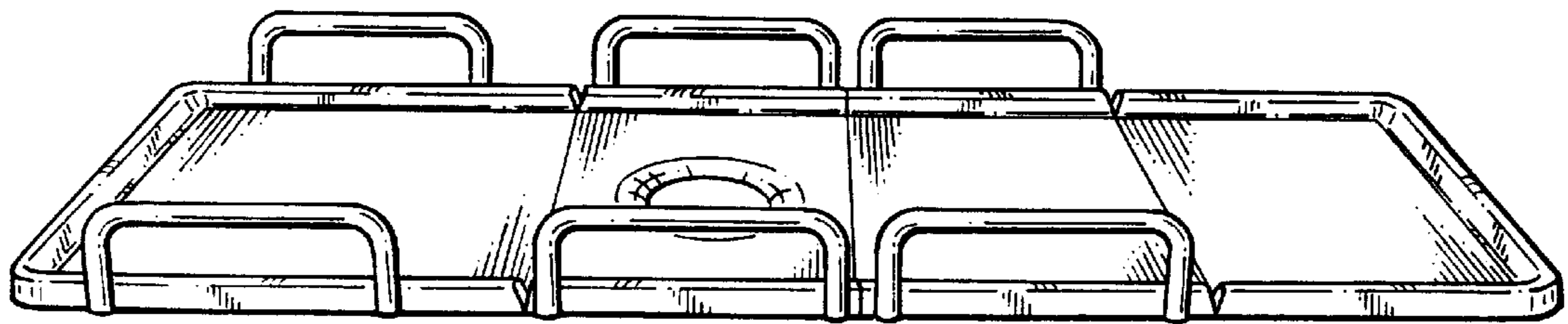

FIG. 3

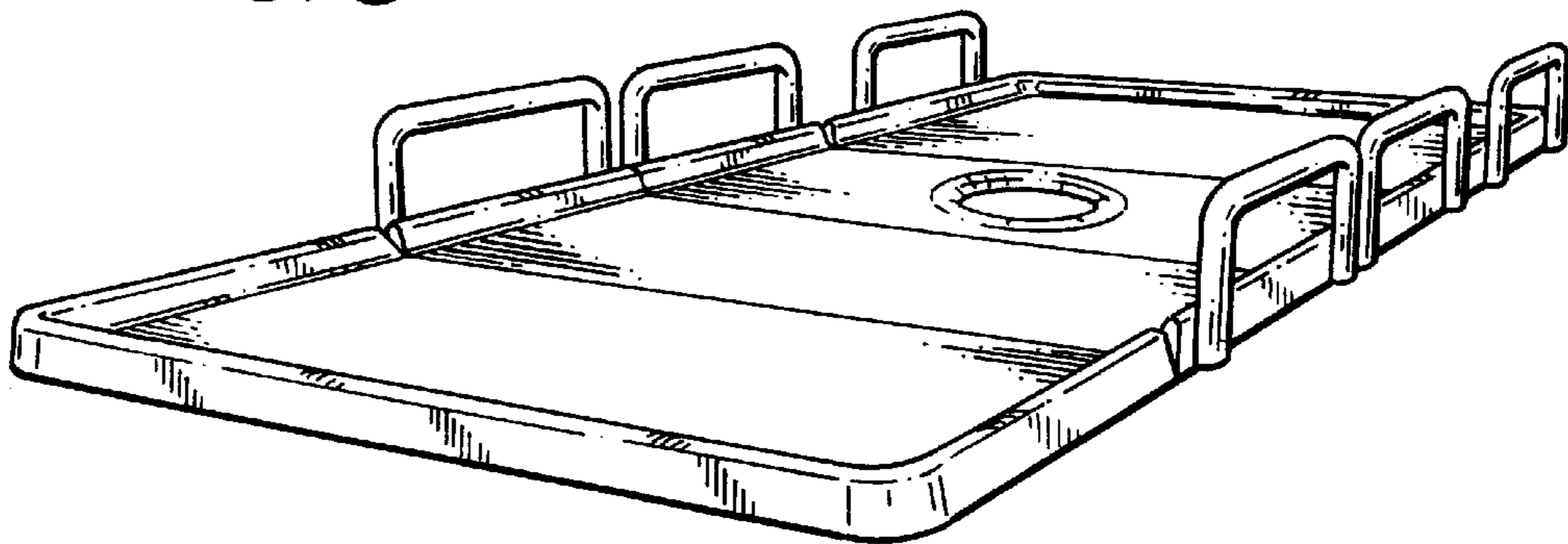

FIG. 4

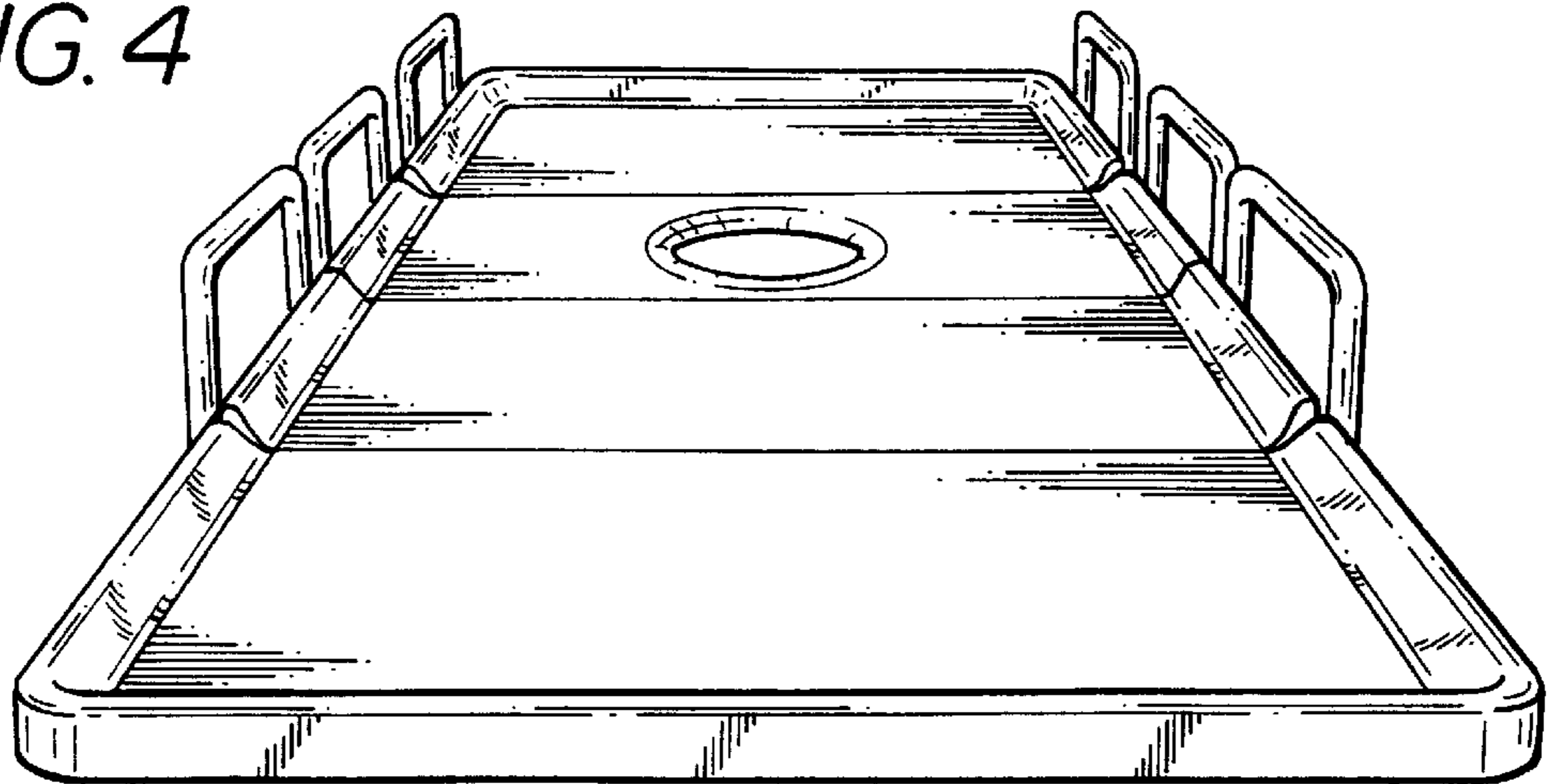

FIG. 5

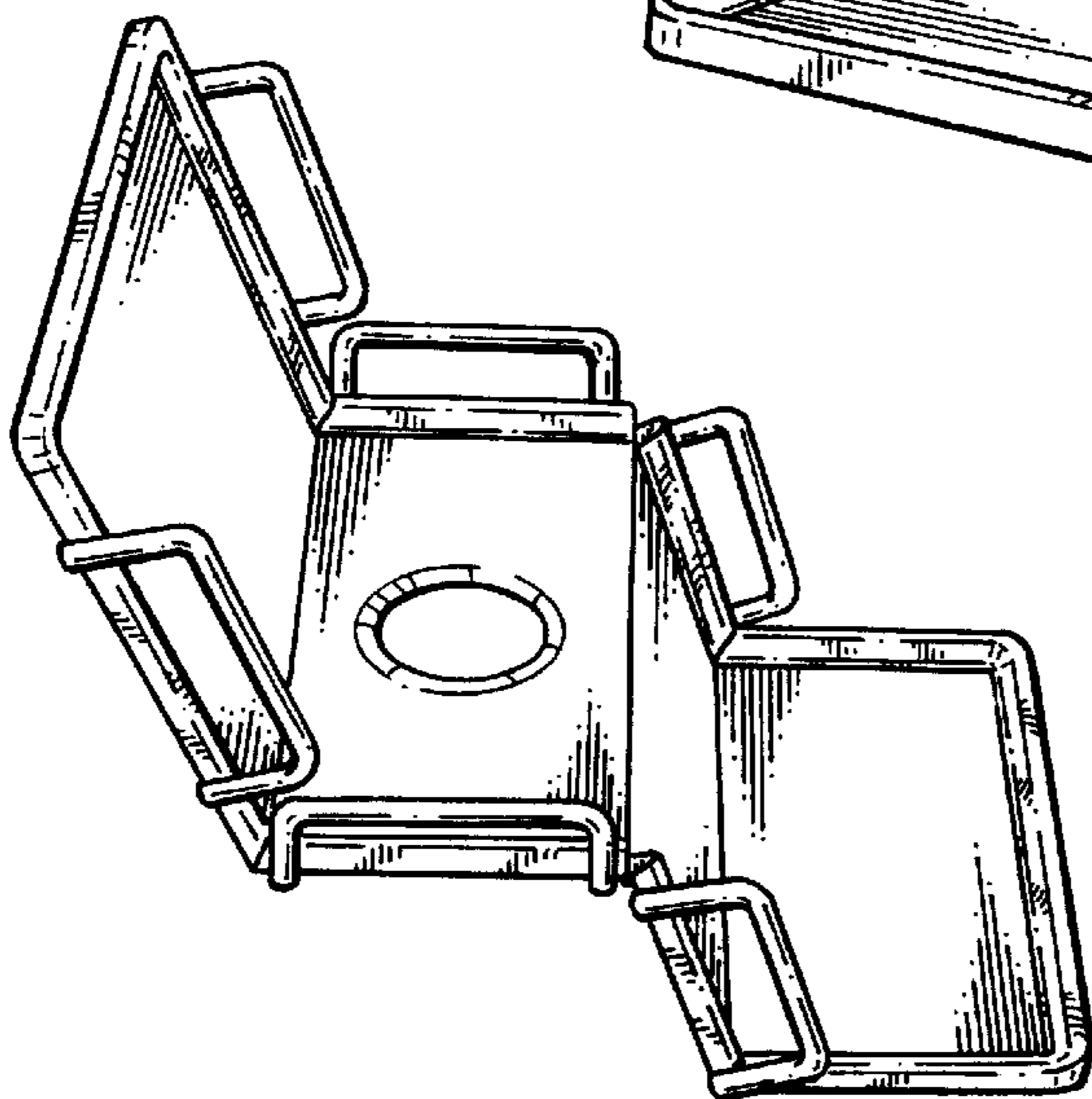
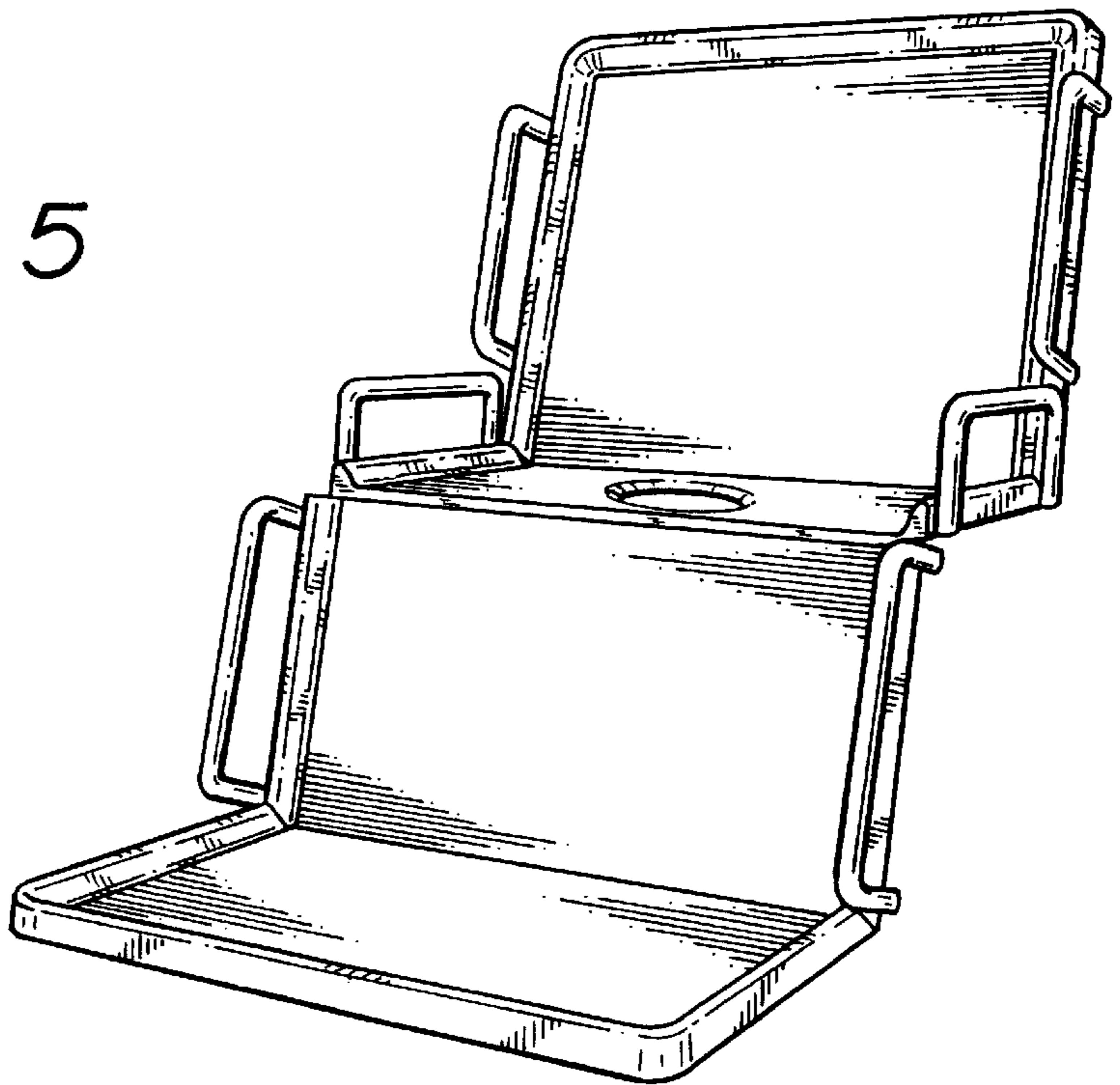

FIG. 6

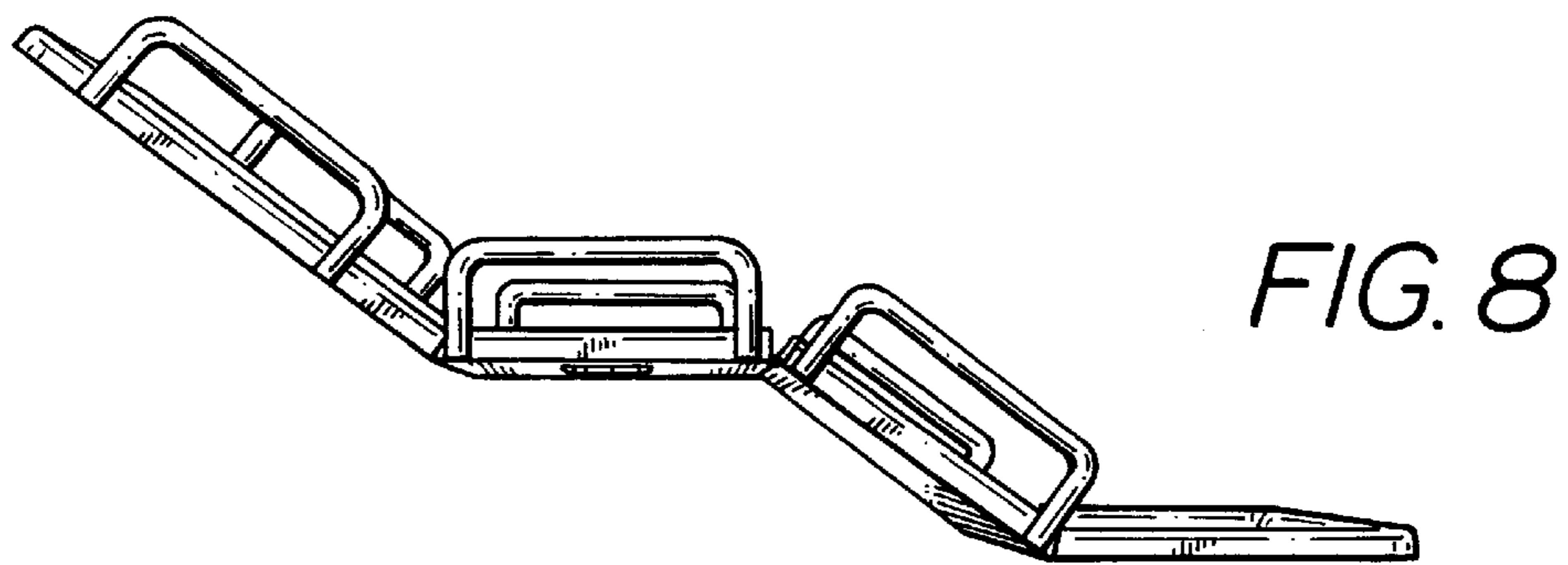
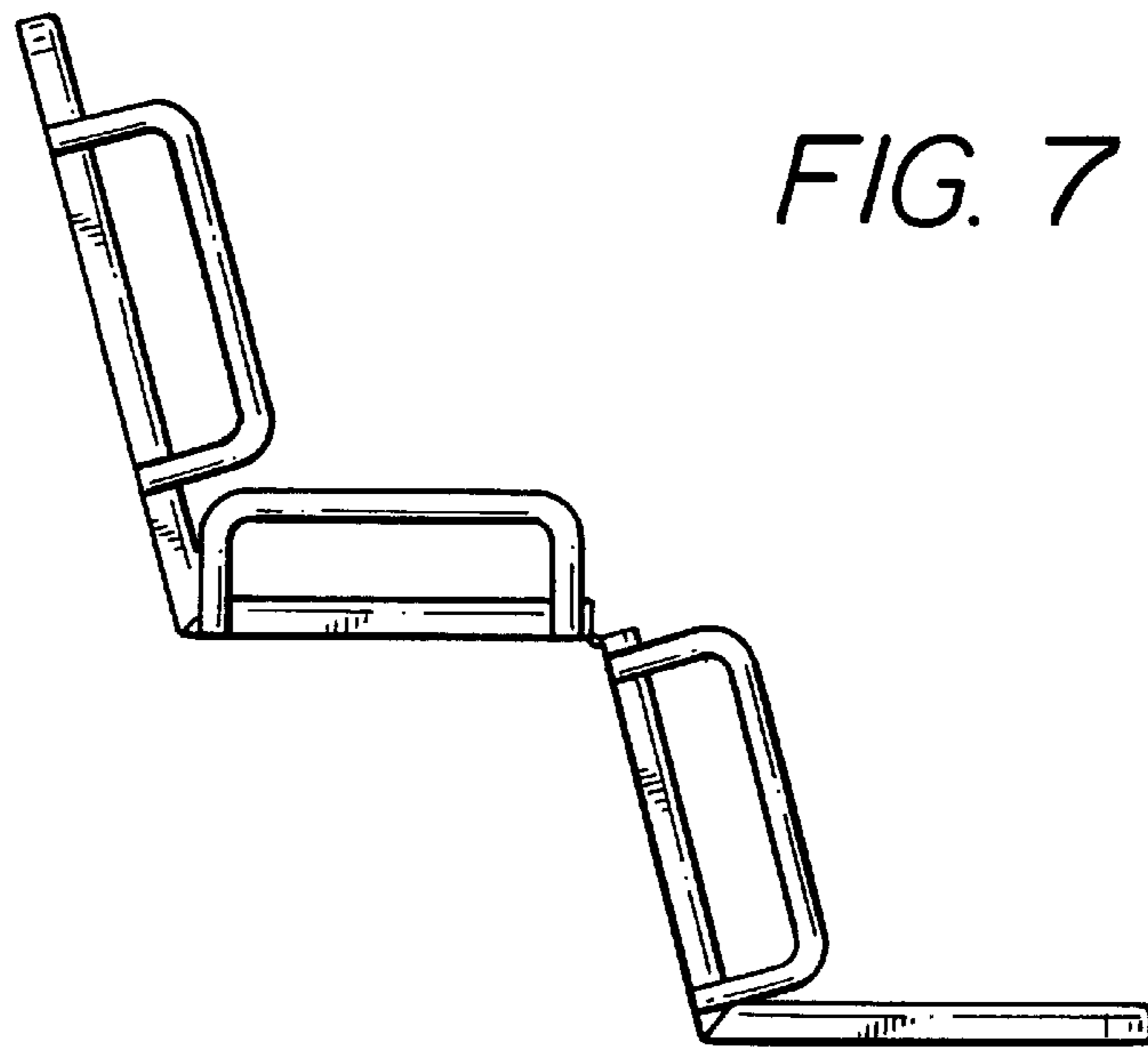

FIG. 9

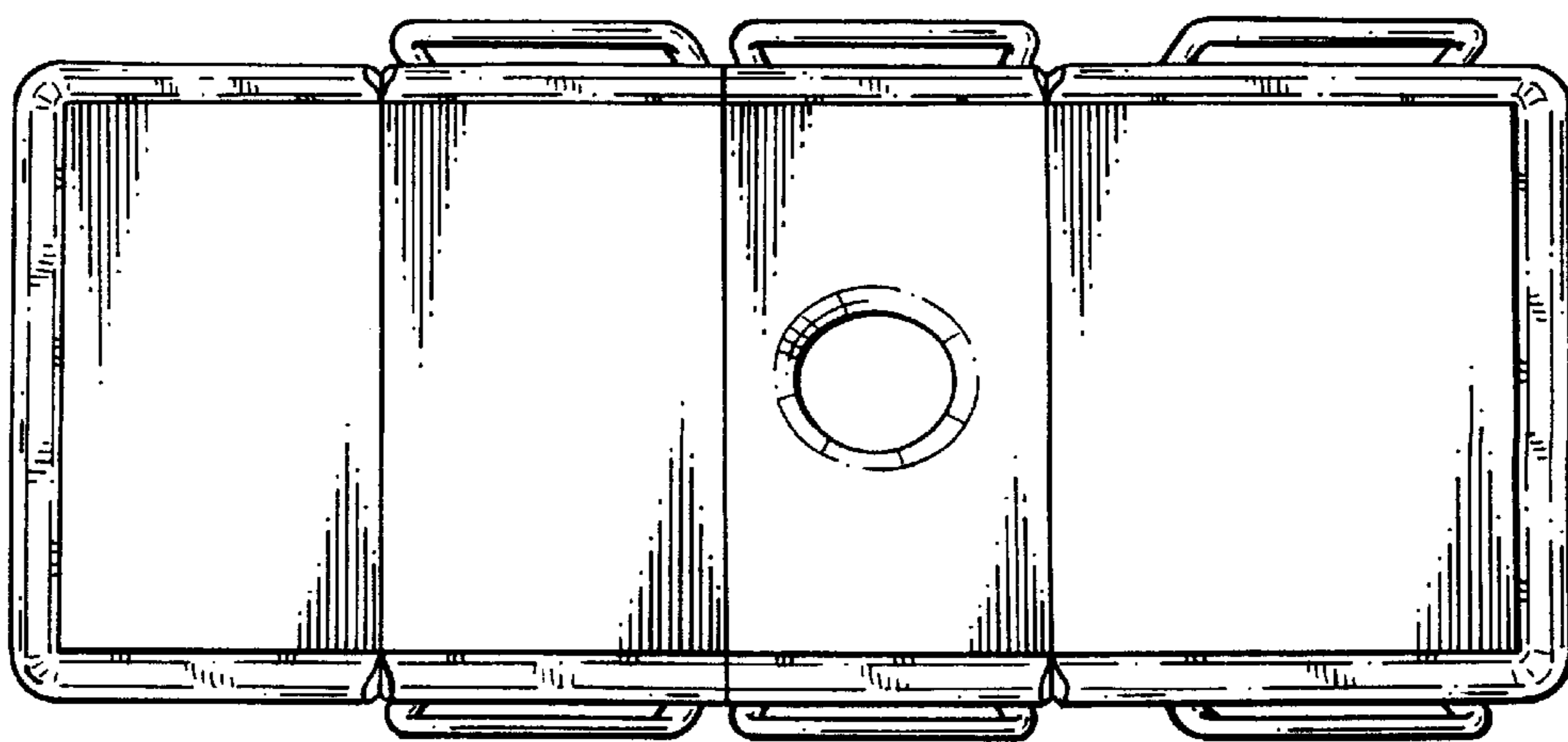

FIG. 10

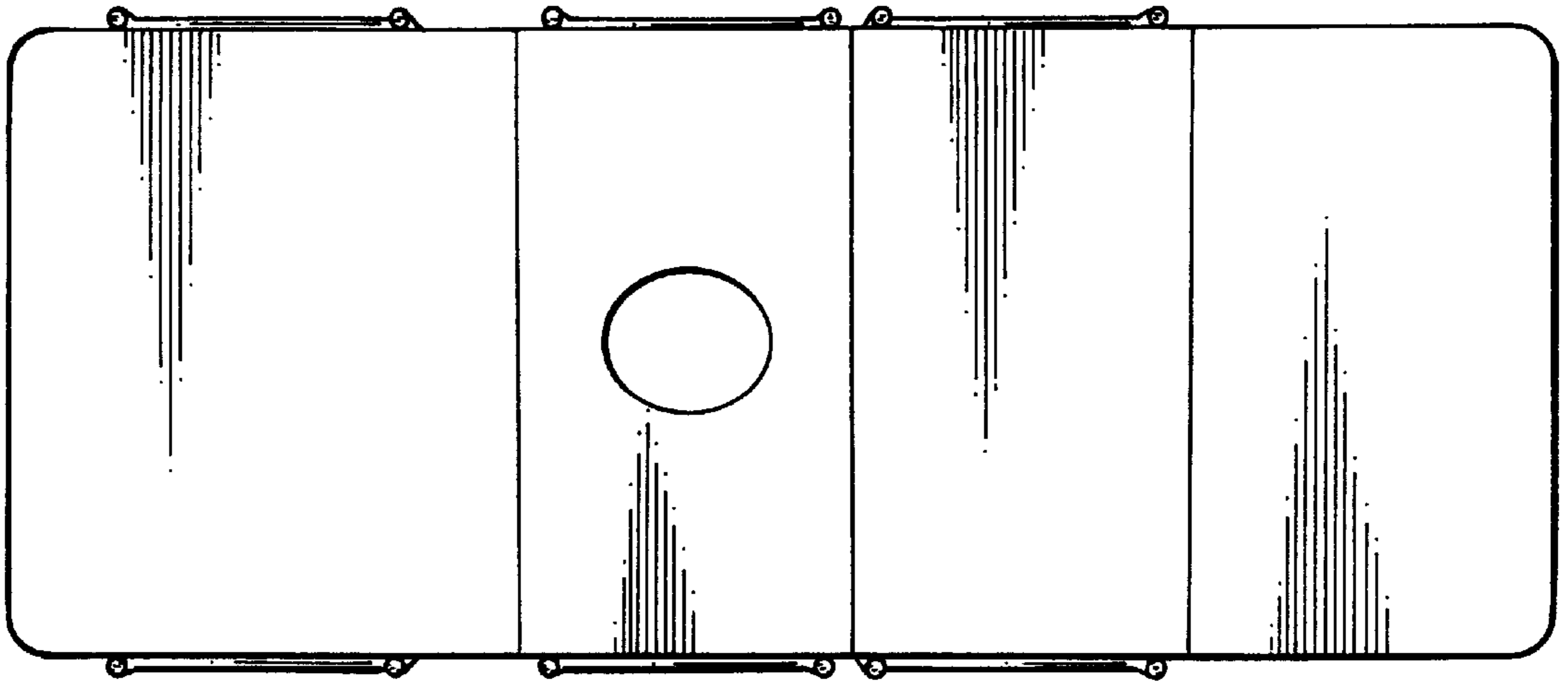

FIG. 11



FIG. 12

